

# RESIDENCE TIME DISTRIBUTION OF SOLID PARTICLES IN A HIGH-ASPECT RATIO MULTIPLE-IMPELLER STIRRED VESSEL

S. Castellino\*, J. Čermáková \*\*, F. Scargiali\*, F. Grisafi\*, V. Machoň\*\*, A. Brucato\*

\* Dip. di Ingegneria Chimica - Viale delle Scienze – 90128 Palermo (Italy)

\*\* Prague Institute of Chemical Technology - Technická 5, 16628 Praha 6 (Czech Rep.)

## ABSTRACT

Despite its importance, experimental information on the Residence Time Distribution (RTD) of solid particles in continuous-flow stirred vessels is still scant. In this work, experimental data on particle RTD in a high-aspect-ratio vessel stirred by three equally-spaced Rushton turbines, was obtained by means of a special technique named *Twin System Approach* (TSA).

Quite surprisingly, results indicate that, among the various possibilities that could have been devised (e.g. 6, or 3, or 1 ideal tanks in series), the flow model closest to reality for the particle phase, at least in the experimental range here investigated, is that of a single perfectly stirred vessel.

## 1 - INTRODUCTION

Particle suspension in stirred vessels is an operation frequently encountered in the process industry (e.g. crystallisers, heterogeneous stirred reactors, leaching vessels, etc.) In most cases, information on the residence time distribution (RTD) of all the phases entering the vessel is of primary importance for both modelling and designing purposes.

As a difference from the case of liquid and gas phases, only few studies can be found for the RTD of particles in stirred tanks [1], a lack of information probably due to the experimental difficulties involved in this kind of studies, where constant flows of slurries with constant composition have to be dealt with.

The Twin System Approach technique (TSA) formerly introduced by Brucato and Rizzuti [2] is a convenient technique able to overcome the above mentioned difficulties and is therefore particularly suited for the assessment of particle RTD in stirred vessels, as it has already been proven in the case of standard stirred vessels [1]. In this paper the TSA is firstly summarised and then applied to the determination of particle RTD in a high-aspect-ratio triple-impeller stirred vessel.

## 2 - THE TWIN SYSTEM APPROACH

The main feature of the Twin-System Approach [1] consists in the duplication of the system to be investigated, so that two identical systems S1 and S2 are set up, as depicted in Figure 1: S2 is identical to S1 in any respect, except for one property of the solid phase contained in S2, which is “traced” with respect to that contained in S1.

At the beginning, the two systems are filled with known and equal amounts of both traced and untraced phase and then operated in a “self recycle configuration” as depicted in Fig. 1a (SRC) with flow rates, agitation speeds and any other operational variable identical for the

two systems. During this time the fraction of traced phase at the outlet of S1 ( $x$ ) is zero while the same fraction at the outlet of S2 is 1. When the two systems have attained steady state conditions the flow configuration is suddenly changed by feeding each system with the outlet of the other, as indicated in Fig. 1b (“cross mixed configuration” CMC). As a consequence the measured value of  $x$  starts evolving, to eventually reach a steady value of 0.5, when complete mixing of the initial contents of the two systems is attained. The  $x$  dynamics is clearly linked to the retention time distribution of the phases in each system, so that proper analysis of the curve  $x(t)$  allows the determination of RTD functions .

With the help of “Z-transforms” it can be easily shown [1] that the  $E_i$  coefficients of the polynomial at the R.H.S. of the following equation:

$$\frac{x_0 + x_1z + x_2z^2 + x_3z^3 + \dots}{(1-x_0) + (1-x_1)z + (1-x_2)z^2 + (1-x_3)z^3 + \dots} \cong \Delta t(E_0 + E_1z + E_2z^2 + E_3z^3 + \dots) \quad (1)$$

simply coincide, with good approximation, with the values of the residence time distribution function  $E(t)$  [4] at times  $i\Delta t$ , where  $\Delta t$  is the time interval between subsequent  $x$  data. Hence, in order to extract the desired RTD information from the  $x(i)$  discrete raw data series typically resulting from an experimental data acquisition, all that needs to be done is a “long-division” between two simple polynomials.

The main advantages of the TSA technique for RTD studies on solid particles are:

- the need for special apparatuses to handle constant flow rates of particulate solids is eliminated as constant slurry flow rates are automatically obtained;
- the amount of solid phase needed to carry out one experiment is minimized.

The technique has already been shown to gives rise to highly discriminating responses, that are correctly converted by eqn.1 into the relevant  $E(t)$  curves, provided that suitably small  $\Delta t$  intervals are adopted [2].

### 3 - EXPERIMENTAL

The investigated vessel is depicted in Fig.3. It was a perspex cylindrical vessel, 100 mm in diameter, 300 mm in height, provided with standard baffles and stirred by three equally spaced Rushton turbines of 50 mm in diameter. Flow inlet was from the vessel top, while the flow outlet was through the bottom, which was spherically shaped in order to help preventing particle deposition. The external circuitry was made of transparent PVC so that the absence of particle deposition could be checked. Its volume was 630 cm<sup>3</sup> for each of the twin system, thus accounting for about 21 % of the total volume. Five different agitation speeds were explored: 400, 600, 800, 1000, and 1400 rpm. Tap water at room temperature was used as the liquid phase for all experimental runs. Accurately sieved silica particles (180-212 μm) were used as solid particles. The total solid particles quantity introduced in each reactor was 175 g, while the total flow rate was always 6 lt/min.

The tracing technique adopted involved the deposition of a very thin layer of strongly coloured iron oxides on the particle surface. A detailed description of the tracing technique and of the traced-fraction continuous detector employed can be found in [1] and [3] respectively. Notably, the iron oxide film deposited on the particles is soluble in aqueous HCl, a property that allows the recovery and re-utilization of the particles after each run.

## 4 - RESULTS AND DISCUSSION

Typical experimental  $x(t)$  data are reported in Fig. 3a. Application of eqn.1 to the discrete  $x(i)$  data leads to the  $E(t)$  values reported in Fig. 3b. The  $E(t)$  curve shows a larger background noise than the  $x(t)$  curve, as the deconvolution operation is a derivative operation which tends to emphasize experimental noise. Nevertheless, the shape of the RTD curve is able to provide useful hints on the possible flow models for simulating the system behaviour.

It is important to note that the data reported in Figs. 3 (a) and (b) do not concern the stirred vessel alone, as they involve also all flushed volumes external to the investigated vessel, *i.e.* tubing, pumps, valves etc. These are needed by any TSA apparatus and their presence, being unavoidably included in the observed (total) system response, is to be compensated somehow in order to obtain the desired RTD in the investigated system alone (the stirred vessel in the present case). In some cases the external volumes can be reduced to a small fraction of the total volume, so that their contribution to the total RTD in the system is negligible with respect to that of the investigated vessel. In all other cases the external circuitry contribution has to be suitably accounted for.

In a previous work [1] the external circuitry was simply treated as a perfect plug-flow, as in that case the external circuitry contribution to the total system response was small and the approximations involved in this idealised compensation did not significantly affect the final results. In the present work this task was instead accomplished by performing a separate TSA experimental run, in which the investigated vessel were by-passed so that only the external volumes were involved.

The need to assess the actual RTD in the external circuitry arises in the present case from the circumstance that unexpectedly large amounts of solid phase were found to be hold-up in the external volumes. As a matter of fact, by suddenly isolating the external tubing (at steady state conditions), and separately recovering the solid particles present into the external circuitry and those inside the stirred vessel, it was found that the amount of particles dynamically residing in the external circuitry was of the order of 50% of the total particles introduced in the system. Such values are larger than those expected on the basis of the external circuitry volume (which is about 21% of the total), and clearly indicate that average particle concentration in the external circuitry is much larger than that inside the vessels. They also imply that half of the overall RTD response of the system is affected by the external circuitry, which has therefore to be accurately modelled if reliable information on the sole stirred vessels is to be extracted from the experimental responses.

A separate TSA experimental run was therefore performed, in which the investigated vessels were by-passed so that only the external volumes were involved. The mass of particles introduced in each system was 85 g, on the basis of the relevant experimental results, while the total flow rate was, as in all other runs, 6 lt/min. The experimental  $x(t)$  curve so obtained is reported in Fig. 4a. As can be seen, it is sensibly different than a typical PFR response [2] while it can be quite well simulated by series of 12 ideal tanks, as shown by the solid lines reported in the Figures 4a and 4b.

Once a model for the solid particles in the external circuitry was available, alternative models for the stirred vessel alone could be devised and tested, by simply adding them to the known external circuitry model.

In devising flow models, attention has to be paid to the system fluid-dynamics and flow patterns. Under this respect, the three radial impellers in each stirred vessel can be expected to give rise to a flow pattern configuration characterised by six main ring vortices (two per stirrer), an expectation confirmed by visual inspection of the vessels during the experimental runs. This observation indicates that a possible model for the investigated vessel may be a series of 6 perfectly stirred tanks, assuming that the inter-exchange rates between the six compartments are small when compared with the exchanges imposed by the external flow-rate. As an alternative, if the inter-exchange rates over the three stirrer planes (where turbulence is highest) were large enough, then a series of 3 CSTR (with possibly some feedback between them) might give rise to a model closer to reality. Obviously, if also the inter-exchanges over the two separation planes midway between stirrers were strong enough with respect to the net flow through the system, then a single perfectly stirred tank would be a suitable model for the investigated vessel.

On the basis of the above considerations, the “Two Series of Tanks Model” (TSTM) illustrated in Fig. 5 was set-up to attempt modelling the total system. The first series of tanks was meant to model the investigated vessel, while the second one was the series of 12 perfectly stirred tanks that had been found to appropriately model the external circuitry.

After a number of attempts, the trial and error procedure eventually led to the conclusion that a single stirred tank is the flow model closest to reality, over the experimental range here investigated. As a matter of fact, in Figures 6 and 7 the  $x(t)$  and for  $E(t)$  the data obtained at all the investigated agitation speeds, are respectively compared with the theoretical curves predicted by modelling the stirred vessels as a single perfectly stirred tank and, as it can be observed, a very good agreement is found. On the other hand, the agreement obtained when modelling each vessel with 3 or 6 perfectly stirred tanks (not reported here for the sake of brevity) was much poorer.

It may be worth noting that by assuming a value of 0.75 for the stirrer Pumping Number, the flow rate pumped by each impeller may be estimated in the range from 0.6 to 2.2 lt/s, over the agitation speed range here explored (400-1400 rpm). These are values from 6 to 22 times larger than the external flow rate of 0.1 lt/s employed, surely indicating that well stirred conditions were to be expected inside each compartment. The same information could give no indication, however, on the inter-exchange rates among the various compartments and therefore on the suitability of 1, 3 or 6 perfectly mixed tanks in series as the model of choice.

## 5 - CONCLUSIONS

The Twin System Approach technique was successfully applied to the determination of the retention time distribution of solids particles in a high-aspect ratio triple-impeller stirred vessel. The need to properly account for the contribution of the external circuitry was addressed by performing separate TSA experimental runs in which only such circuitry was involved.

Results on the RTD in the stirred vessel alone quite surprisingly indicate that, among the various possibilities that could have been devised (e.g. 6, or 3, or 1 ideal tanks in series), the flow model closest to reality for the particle phase, at least over the experimental range here investigated, is that of a single perfectly stirred vessel.

## REFERENCES

- [1] Brucato, A., Brucato, V., Rizzuti, L., 1992, *Chem. Eng. Comm.*, **115**, 161-181.
- [2] Brucato, A., Rizzuti, L., 1989, *Chem. Engng. Journal*, **42**, 73-82.
- [3] Brucato A., Brucato V., 1998, *Can. J. of Chem. Eng.*, **76**, 420-427
- [4] Levenspiel O., 1972, *Chemical reaction engineering (2nd ed.)*, (pp. 253-325). Wiley (New York).

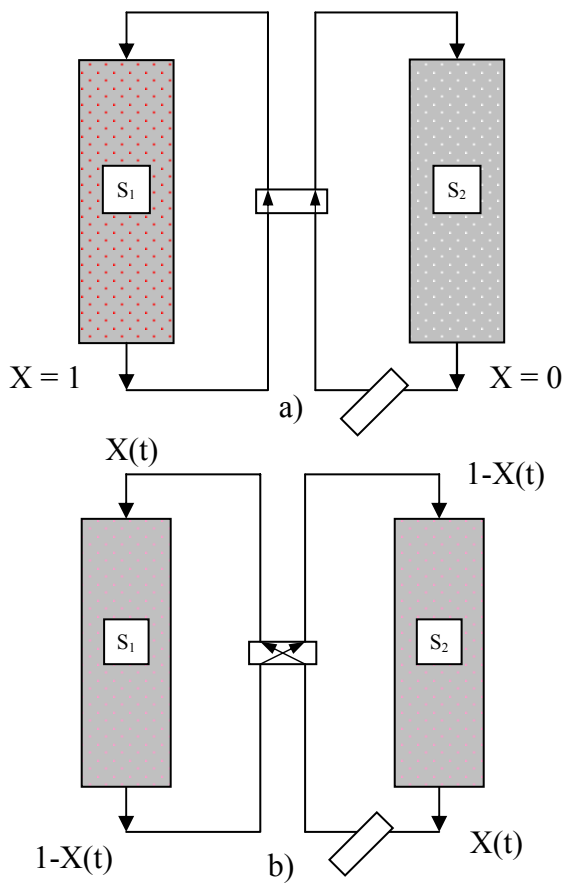

Fig. 1: Twin system configurations

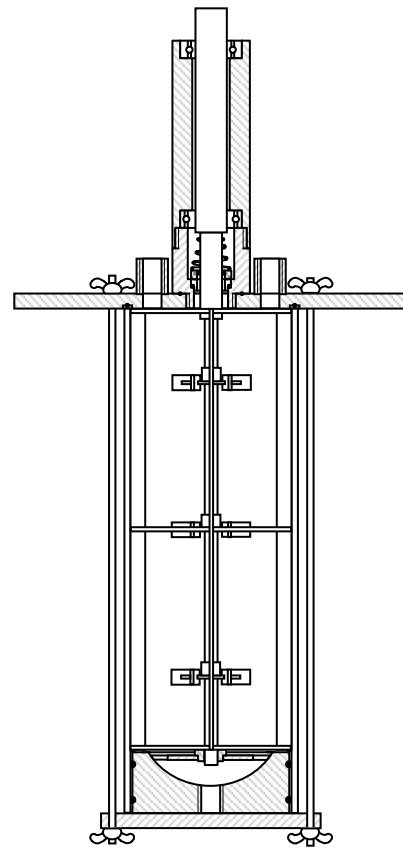

Fig. 2: Stirred vessel employed

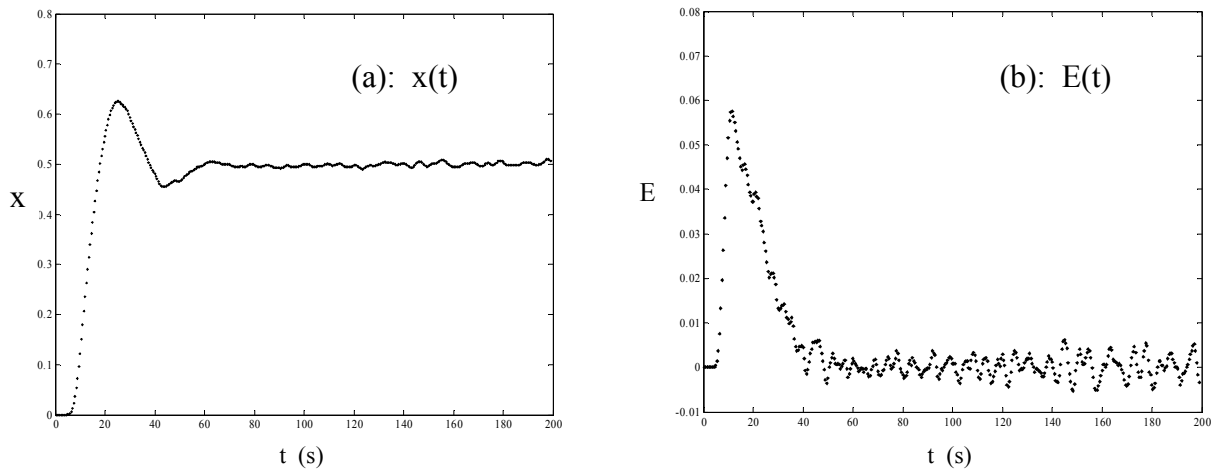

Fig. 3: Typical experimental  $x(t)$  and  $E(t)$  data for  $N=1000$

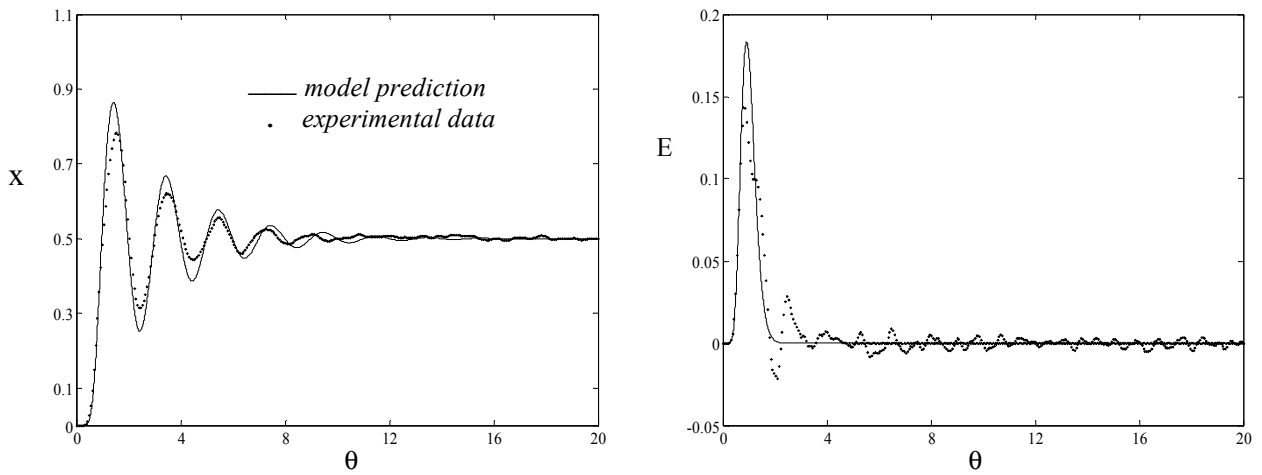

Fig. 4: Experimental and modelled  $x(t)$  (a), and  $E_t(t)$  data (b), for external circuitry: solid line: Tanks in Series Model with  $N_R=12$

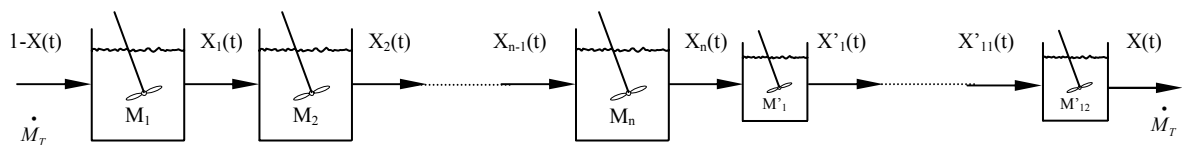

Fig. 5: Two series of Tanks Model

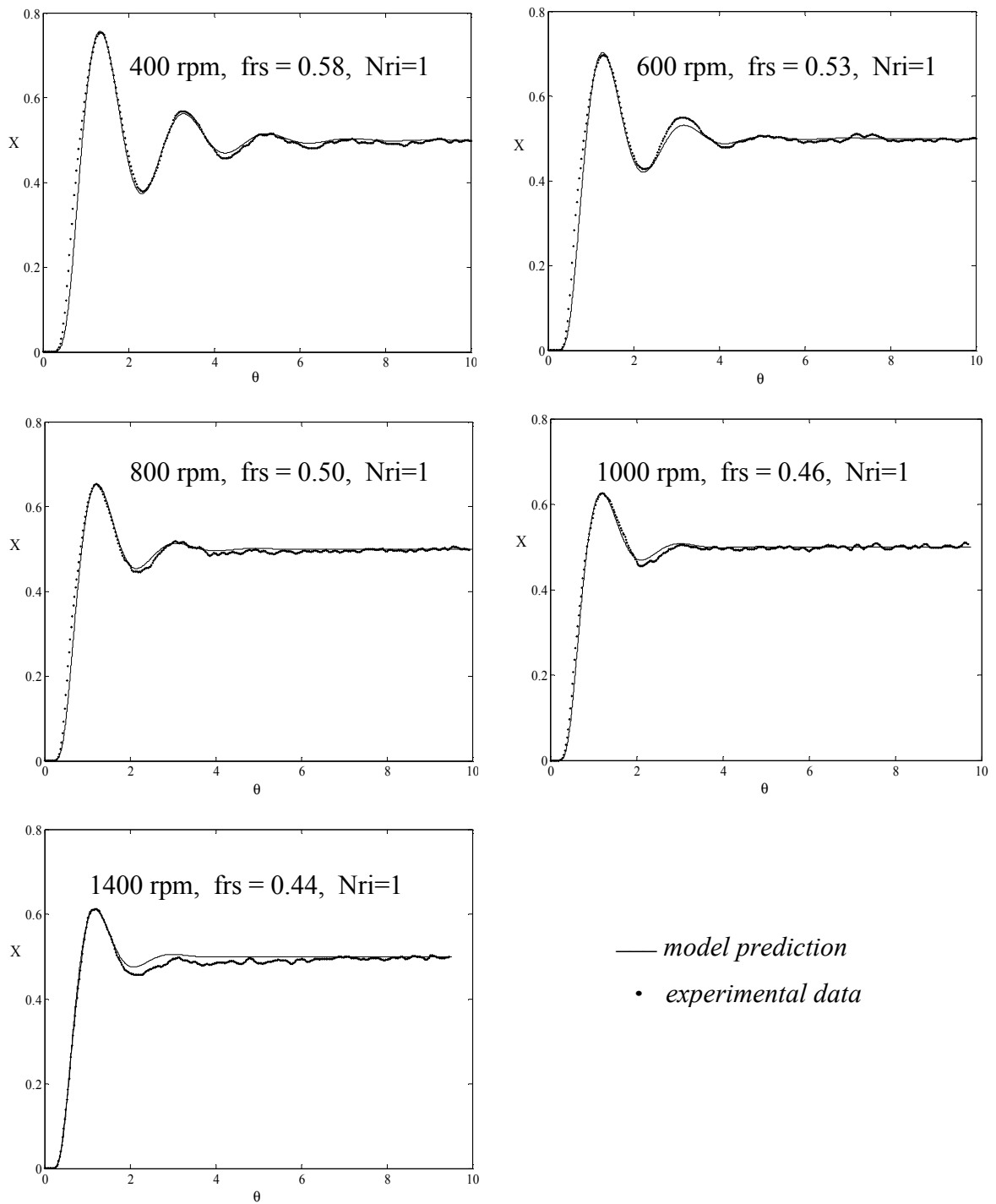

Fig. 6: Experimental and predicted  $x(t)$  data: Two series of Tanks Model (TSTM)

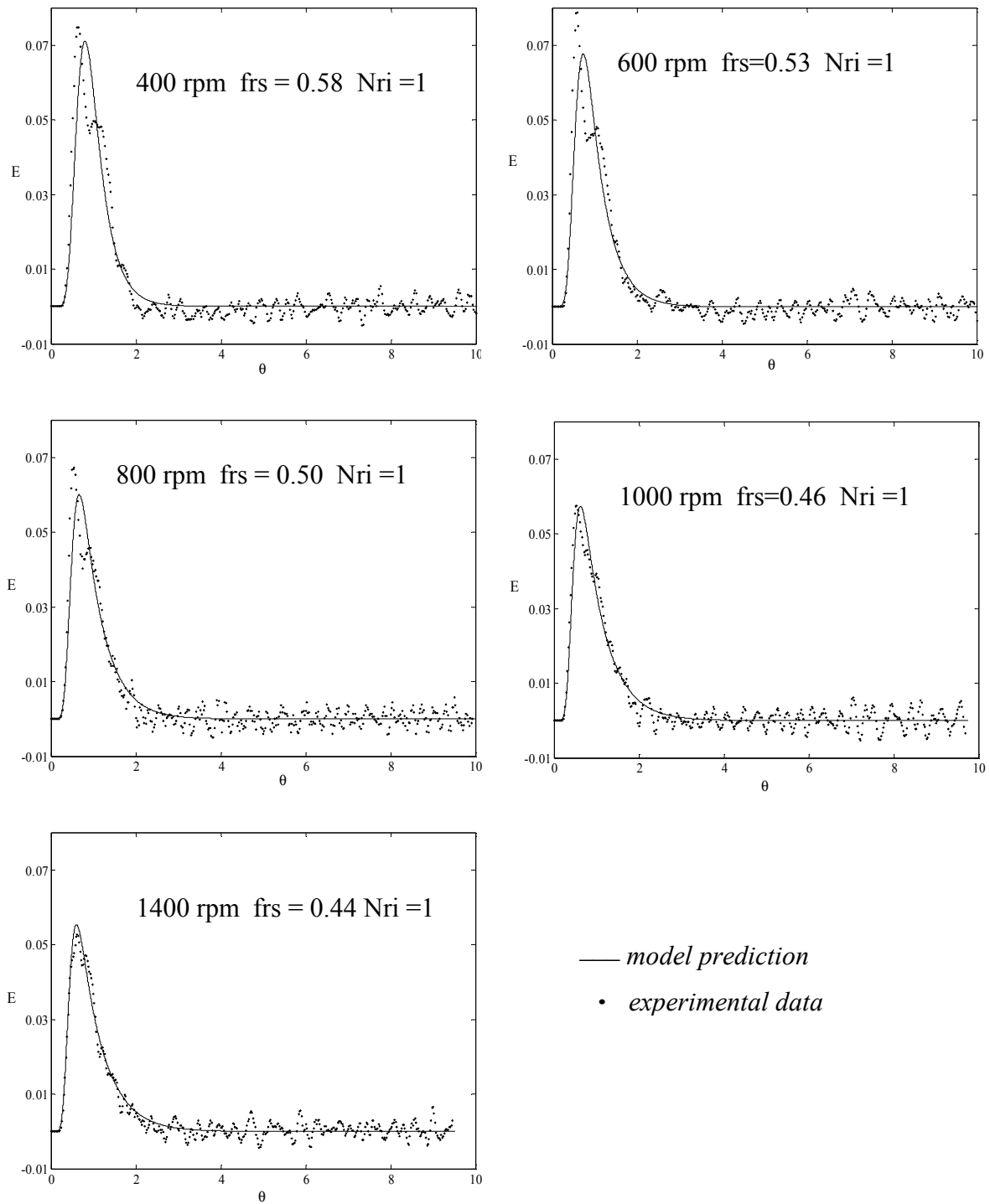

Fig. 7: Experimental and predicted  $E_t(t)$ : Two Series of Tanks Model (TSTM)