

Study of the thermo-mechanical performances of the EU-DEMO Water-Cooled Lead Lithium Left Outboard Blanket segment

S. Giambrone^{a,*}, P. Arena^b, G. Bongiovì^a, I. Catanzaro^a, A. Del Nevo^b, P.A. Di Maio^a, E. Tomarchio^a, E. Vallone^a, S. Basile^a

^a Università degli Studi di Palermo, Viale delle Scienze, Edificio 6, 90128 Palermo, ITALY

^b ENEA, Department of Fusion and Nuclear Safety Technology, C.R. Brasimone, 40032 Camugnano (BO), ITALY

ARTICLE INFO

Keywords:

WCLL
Breeding blanket
Lateral outboard
Thermomechanics
FEM analysis

ABSTRACT

The development of a sound conceptual design for the Water-Cooled Lead Lithium Breeding Blanket (WCLL BB) is pivotal to make a breakthrough towards the selection of the driver blanket concept for the EU-DEMO. To this goal, a research campaign has been launched over the last years at the University of Palermo, in close cooperation with ENEA Brasimone, under the umbrella of EUROfusion. In this frame, the analysis of the thermo-mechanical behaviour of the WCLL Left Outboard Blanket (LOB) segment is being performed. In a first phase, the assessment of the segment's overall structural performances was addressed, allowing the investigation of its global response under the selected loading scenarios. On this basis, the local structural analysis of the central region and of the upper and lower regions presenting geometric discontinuities (namely those regions where the stiffeners numbers changes) is presented in this paper, with the aim of assessing in detail their structural behaviour under the nominal BB operating conditions as well as steady-state accidental loading scenarios. Adopting the sub-modelling technique, the displacement field calculated in previous LOB global structural analysis can be mapped and applied at the boundaries of each local model. Moreover, it is possible to include there some structural details missing in the global analysis, like the Segment Box cooling channels. In this way, it is possible to study the thermo-mechanical behaviour of these regions in detail, assuming at the borders the mechanical action of the rest of the structure. The assessment has been performed in compliance with the RCC-MRx code, adopting the set of criteria on the basis of the nature of the considered loading scenario. The obtained results showed a promising structural behaviour of the segment and highlighted the necessity to revise the attachment system layout, which originates excessive deformation leading to the prediction of high stress.

1. Introduction

Within the framework of the research activities concerning the EU-DEMO Breeding Blanket (BB) [1], promoted by the EUROfusion consortium, the University of Palermo is involved in the design of the Water-Cooled Lead Lithium (WCLL) BB, in close cooperation with ENEA. The in-depth investigation of the structural behaviour of an entire BB segment under different loading scenarios and the evaluation of its performances in view of the design requirements is pivotal for the design of the whole DEMO reactor. To this purpose, the detailed structural behaviour of the WCLL Left Outboard Blanket (LOB) segment, under nominal and accidental loading scenarios, has been assessed and reported in this paper.

Modelling and investigating such complex component, as the entire

segment, is quite challenging. Therefore, assumptions are usually taken and alternative strategies, such as the removal of certain structural details, are adopted to allow the best compromise in between results accuracy, modelling effort and computational burden. On the one hand, this approach allows to speed-up the calculations and to reduce the computational burden so to obtain a complete structural response of the entire segment; on the other hand, it does not allow to know the detailed behaviour of certain regions of particular interest. Hence, with the aim of studying in detail the structural performances of the WCLL LOB segment, a two-phase analysis approach has been followed.

In a first phase [2], the overall structural behaviour of the entire WCLL LOB segment was investigated in order to obtain the global response of the whole component under the prescribed loading conditions. To this end, some geometric details (such as the internal tubes, the

* Corresponding author.

E-mail address: salvatore.giambrone04@unipa.it (S. Giambrone).

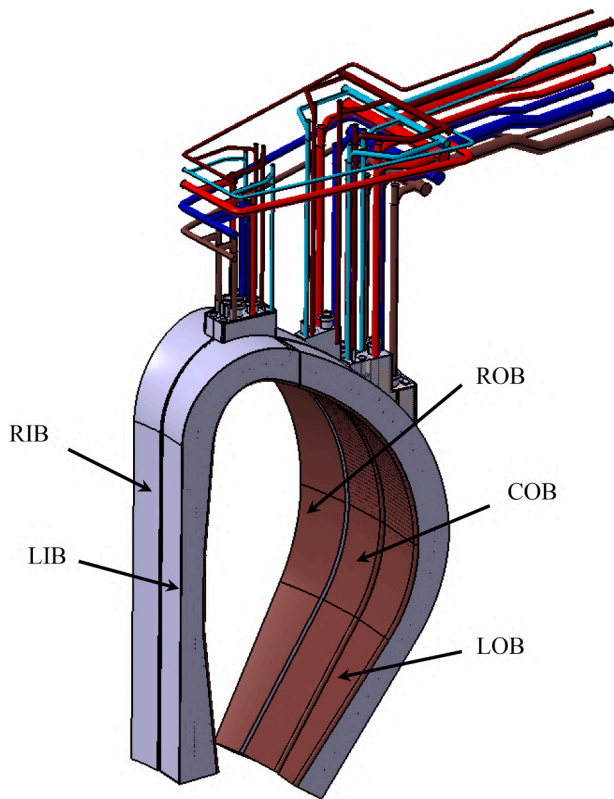

Fig. 1. EU-DEMO WCLL BB sector architecture.

baffle plates and the segment box cooling channels) were not included into the model, in order to significantly reduce the modelling effort, and a rough mesh has been developed so to minimize the computational burden allowing to speed-up the calculations.

Afterwards, as reported in the present work, the sub-modelling technique has been adopted in order to perform in-depth investigations of the structural performances of some regions. To this goal, local models of the regions of interest have been developed, properly including all the structural details not considered in the previous global analysis and generating a fine mesh in order to improve the results reliability. Then, the displacement field calculated in the global analysis in correspondence of the local models' borders has been properly mapped and applied, for each considered loading scenario, so to realistically reproduce the mechanical action of the not-modelled segment's portions onto the local models representative of the regions of interest. Thus, on the basis of the thermo-mechanical analysis of the entire WCLL LOB segment [2], three different poloidal regions have been selected and analysed in detail. In particular, the central region and the two so-called "transition regions", i.e. where the vertical Stiffening Plates (SPs) number change from three to five, have been investigated.

As already done for the global analysis, three different steady state loading scenarios have been considered: the Normal Operation (NO) scenario, representing the operational condition the segment undergoes in the flat-top plasma state, the Over-Pressurization (OP) scenario, representing a conservative load combination derived from an in-box LOCA accident, and the Upper Vertical Displacement Event (UVDE) scenario, a steady state scenario derived from a plasma disruption considering the Electro-Magnetic (EM) loads at the most critical time step. The structural behaviour of the assessed local regions has been evaluated in view of the RCC-MRx structural design criteria [3], verifying the fulfilment of the Level A (for NO scenario), Level C (for UVDE scenario) and Level D (for OP scenario) rules. It has to be underlined that due to the lack of information on structural material properties under fusion conditions and the purely conceptual character of the DEMO

project at the moment, the goal of the thermo-mechanical analyses and the corresponding stress assessments carried out have an indicative purpose and cannot be yet a complete and exhaustive assessment of all rules reported in the RCC-MRx.

The study has been carried out following a theoretical-numerical approach based on the Finite Element Method (FEM) and adopting the commercial FEM code Abaqus v. 6.14 [4]. After a brief description of the WCLL LOB segment geometric layout (Section 2), the 3D FEM models set-up are depicted in the following Section 3 focussing on the applied loads and boundary conditions representing the considered loading scenarios. Then the obtained results are reported and critically commented in Section 4, leaving the conclusion to the final section.

2. The WCLL LOB segment

The EU-DEMO BB is subdivided into 16 toroidal sectors of 22.5° in toroidal direction, each one composed by 5 BB segments (Fig. 1): two in the Inboard side, Right and Left Inboard Blanket (RIB and LIB), and three in the Outboard side, Left, Central and Right Outboard Blanket (LOB, COB and ROB). Looking at the lateral Outboard segments, they differ from the Central one by the asymmetric Side Walls (SWs), which close laterally the segment. Instead, the two inboard segments are designed according to a symmetric layout. The DEMO WCLL BB architecture is based on the Single Module Segmentation, foreseeing only two Caps closing the segment in the top and bottom part, and a single toroidal-radial elementary cell, or Breeder Unit, identified by two horizontal SPs, repeats approximately 100 times along the entire poloidal length of the segment, from one cap to another. The geometric layout of the WCLL LOB segment, assessed in the present work, is depicted in Fig. 2. The external steel structure of each segment is composed of a First Wall-Side Wall (FW-SW) region, named Segment Box (SB), in which $7 \times 7 \text{ m}^2$ square cooling channels are located, covered by 2mm-thick of Tungsten, coloured in orange in Fig. 2. At the back, the structure is closed by a Back Supporting Structure (BSS) which is connected to the Vacuum Vessel (VV) by means of an attachment system (in grey in Fig. 2). Internally, the structure is reinforced thanks to toroidal-radial and poloidal-radial SPs, namely horizontal (SP_h) and vertical (SP_v), which are 10 and 12 mm thick, respectively. The PbLi flows inside the box, throughout the SPs, in the so-called Breeder Zone (BZ), actively cooled by bundles of cooling tubes, Double Walled Tubes (DWTs), differently distributed along all the poloidal length of the segment. Subcooled water, at the operational pressure of 15.5 MPa and an inlet/outlet temperature equal to 285/328°C, flows inside both DWTs and SB cooling channels. A Back Plate (BP) separates the BZ from the PbLi and water manifolds regions, located at the rear of the segment. The selected structural material for the WCLL BB concept is Eurofer97 RAFM steel (in green in Fig. 2). The SB is actively cooled by means of cooling channels. Regarding their layout, 4 channels per elementary slice are foreseen along the LOB entire poloidal length except the lower region, near to the bottom cap, where 6 channels per slice are necessary to cope with the plasma thermal flux [5]. The main dimensions of the WCLL LOB segment central region are reported in Fig. 3.

In the first phase of the analysis [2], a proper DWTs layout for the WCLL LOB central region (Fig. 3) has been obtained, starting from the reference COB DWTs configuration. In particular, the LOB DWTs spatial arrangement and layout has been obtained by means of a parametric campaign of analysis, adapting the reference DWTs configuration to the LOB asymmetric shape in order to ensure that the maximum temperature within the structure stays below the 550°C . Then, the 3D thermal field arising within the central region has been calculated and spread to the whole segment thanks to a purposely set-up analytical procedure [6]. In the end, the global structural assessment of the whole segment has been performed to put the basis for the work reported in this paper.

In this work, in order to investigate in detail the structural behaviour of the central region and of the two (upper and lower) transition regions, the corresponding geometric layouts have been extracted from the

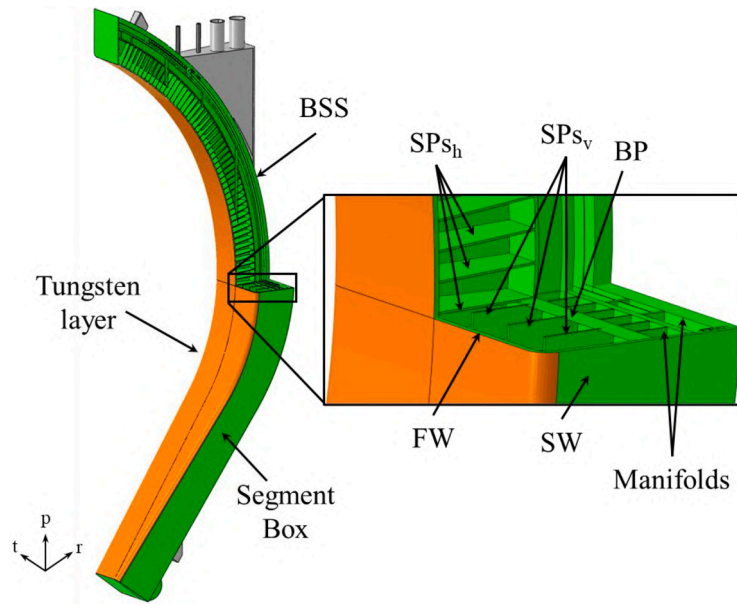

Fig. 2. Overview of the WCLL LOB segment.

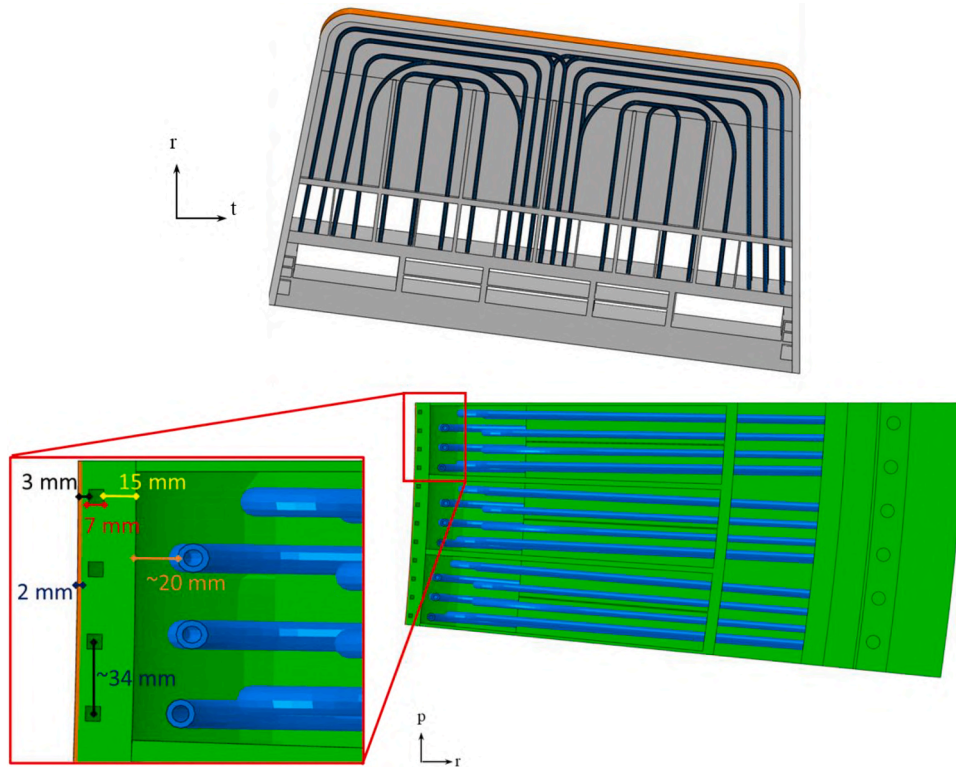

Fig. 3. WCLL LOB DWTs layout in the central region and main dimensions.

geometric model of the whole WCLL LOB segment, and the SB channels have been inserted. In particular, given their location, the three assessed regions are characterised by 4 SB cooling channels per elementary slice (Fig. 4). Hence, the 3 geometric models encompass the proper portions of tungsten layer, of SB, of SPs, of BSS and of BP and manifolds. The breeder and the coolant have not been directly included into the model, since their mechanical action has been considered imposing proper pressure loads onto the water and PbLi wetted surfaces, as explained in the following. In particular, the transition regions are those regions where the number of vertical stiffeners changes from 3 to 5 (as to the

upper region) and from 5 to 3 (as to the lower region). Due to the SB shape, these two regions are not equidistant from the central one, along the poloidal coordinate. Hence, it is necessary to study both since no poloidal symmetry can be assumed in this respect.

3. The FEM models

With the aim of performing the detailed structural analysis of the three WCLL LOB regions of interest under the selected NO, OP and UVDE steady state loading scenarios, the corresponding 3D FEM models have

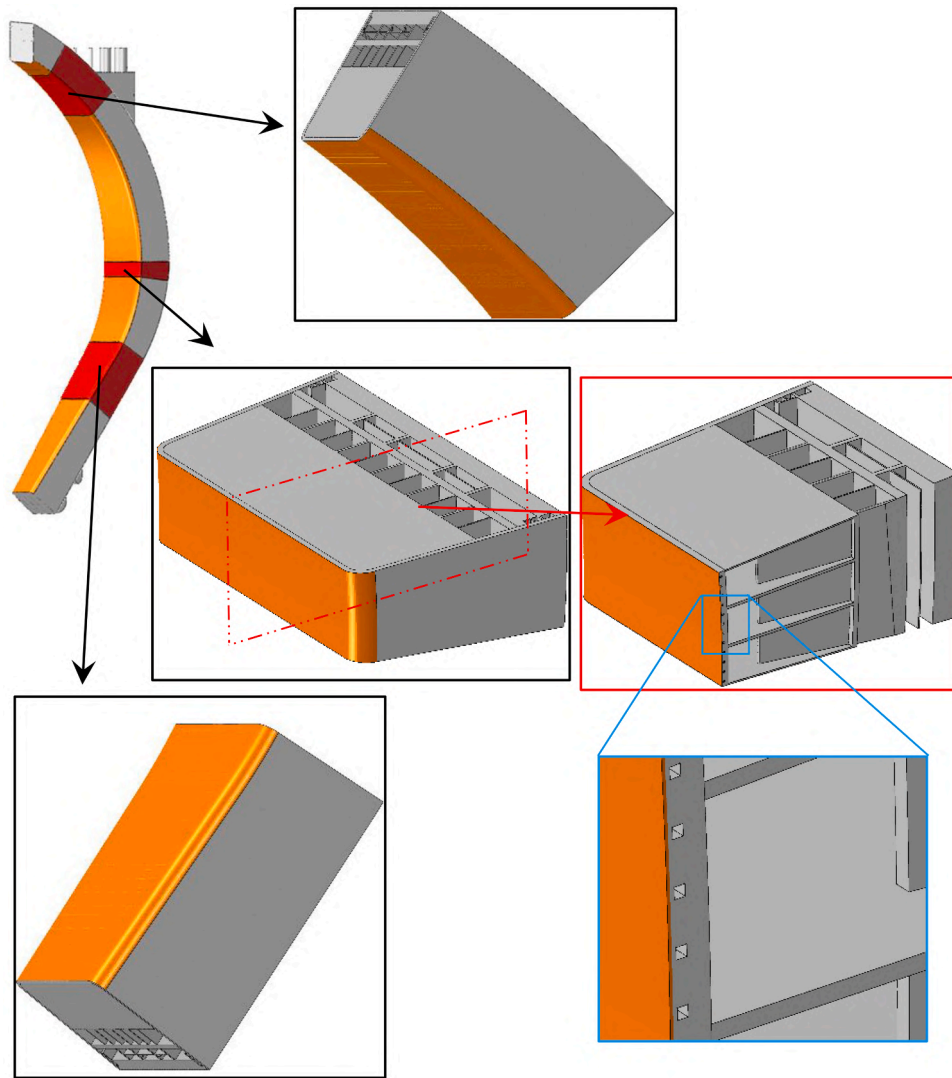

Fig. 4. Location of the central and of the two transition regions in the LOB segment.

Table 1
Mesh features.

	Central region	Upper transition region	Lower transition region
Nodes	1'335'790	2'515'242	2'615'380
Elements	1'144'640	7'549'782	7'888'391

been set-up starting from the geometric configurations depicted in the previous section. First, a mesh has been generated for each of the geometric configurations taken into account and then the sets of loading and boundary conditions have been properly applied in order to reproduce the considered loading scenarios.

3.1. The mesh

As far as the mesh is concerned, each spatial discretization grid is composed of a mix of linear hexahedral and tetrahedral elements. The mesh features, in terms of node and element numbers, are reported in Table 1. Comparing the mesh set-up for the central region of the entire LOB segment (i.e. the mesh of the global model) and that of the local model reproducing in detail the same region, it can be observed that the latter is much finer (Fig. 5) than the former. This allows a more accurate prediction of the mechanical behaviour of the region, as well as a good

accuracy in the results of the stress linearization procedure since the components thicknesses are discretized with a considerable number of elements.

3.2. Loads and boundary conditions

The thermo-mechanical performances of the three selected regions of the WCLL LOB segment have been studied under three steady state loading scenarios, NO, OP and UVDE. The NO scenario considers the load combination arising under the nominal operating condition (i.e. in the flat top plasma state) and it is classified under the service level A in the RCC-MRx structural design loads. The OP loading scenario, instead, considers a severe accidental scenario, due to an in-box LOCA entailing the pressurization of the whole box, classified as Level D. Lastly, the UVDE ones refers to an off-normal event reproducing an uncontrolled vertical plasma disruption, being classified as Level C. In this regard, the most critical time step of the UVDE transient event has been selected, considering the corresponding spatial distribution of the electromagnetic loads.

The following kinds of loads and boundary conditions, featured with more details in Table 2, have been generally considered for the three assessed scenarios:

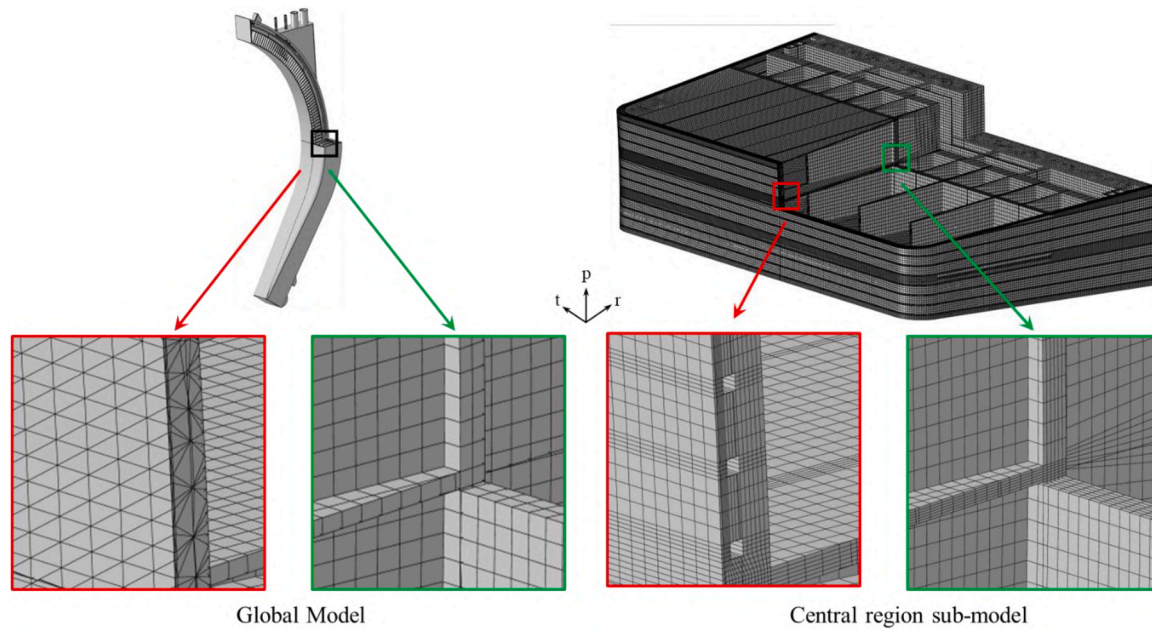

Fig. 5. Mesh details in the central region of LOB global model and sub-model.

Table 2
Summary of the applied loads and boundary conditions.

Scenario	Thermal loads	Gravity loads	EM loads	Pressure loads [MPa]	Mechanical restraints
NO	3D thermal field	Temperature-dependent Eurofer equivalent density	Ferromagnetic loads	$P_{water} = 17.825$ $P_{PbLi} = 0.575$	LOB segment displacement field in NO onto top and bottom surfaces
OP	3D thermal field	Temperature-dependent Eurofer equivalent density	Ferromagnetic loads	$P_{water} = 17.825$ $P_{PbLi} = 17.825$	LOB segment displacement field in OP onto top and bottom surfaces
UVDE	3D thermal field	Temperature-dependent Eurofer equivalent density	Ferromagnetic loads + Lorentz forces	$P_{water} = 17.825$ $P_{PbLi} = 0.575$	LOB segment displacement field in UVDE onto top and bottom surfaces

- non-uniform thermal deformation field;
- pressure loads;
- gravity load;
- electro-magnetic loads;
- mechanical restraints.

The 3D non-uniform temperature spatial distribution already obtained in the first phase of the study [2] and used to investigate the overall structural performances of the whole WCLL LOB segment, has been applied to the three assessed regions. In particular, in Fig. 6, the thermal field applied to the three local models is depicted as super-imposed to the whole LOB segment’s temperature spatial distribution.

As prescribed by the BB Load Specifications [7], the design pressure has been applied onto the water-wetted and the breeder-wetted surfaces, to take into account the mechanical action of the coolant and of the breeder, even in the NO scenario. It corresponds to the fluid nominal pressure (15.5 MPa for water, 0.5 MPa for breeder) increased by a factor of 1.15. Hence, for all the three assessed scenario, a pressure of 17.825 MPa has been considered for the water-wetted surfaces, namely the SB cooling channels and the water manifolds. With regard to the breeder zone (i. e. the SB internals) and PbLi manifolds, in NO and UVDE scenario a pressure value of 0.575 MPa has been considered. Instead, since the OP scenario represents a severe load combination derived from a leakage of coolant and the complete pressurization of the SB, a pressure of 17.825 MPa has been assumed for the breeder-wetted surfaces too.

Moreover, the gravitational load has been applied to the three assessed regions. Since neither the water nor the PbLi have been included into the FEM models, in order to take into account their contribute in terms of weight force, a set of temperature-dependent equivalent density values has been calculated and imposed to the Eurofer structural material according to the formula:

$$\rho_{eq}(T) = \frac{\sum_i \rho_i(T) \cdot V_i}{V_{tot}}$$

where $\rho_i(T)$ is the temperature-dependent density of the i -th material (steel, water or breeder) and V_i / V_{tot} is its volumetric fraction within the structure. Instead, as to the tungsten, its temperature-dependent density has been used.

The 3D spatial distribution of the electro-magnetic forces has been applied to the structures in all the assessed steady state loading scenarios. In particular, during the NO and OP loading scenarios, only the 3D spatial distribution of the ferromagnetic forces has been considered since they arise because of the ferromagnetic nature of the Eurofer steel. In addition, during the UVDE scenario, both the ferromagnetic and Lorentz’s forces must be considered. The UVDE is a transient event, but in order to perform structural analysis the most critical time step of the EM loads has been selected by looking and the time behaviour of the force and moment components reported in Fig. 7, where it is clearly visible that the maximum component is the radial one. For the LOB segment the time steps corresponding to the maximum of the radial force and moment are coincident and equal to 11.594 s. Hence, the

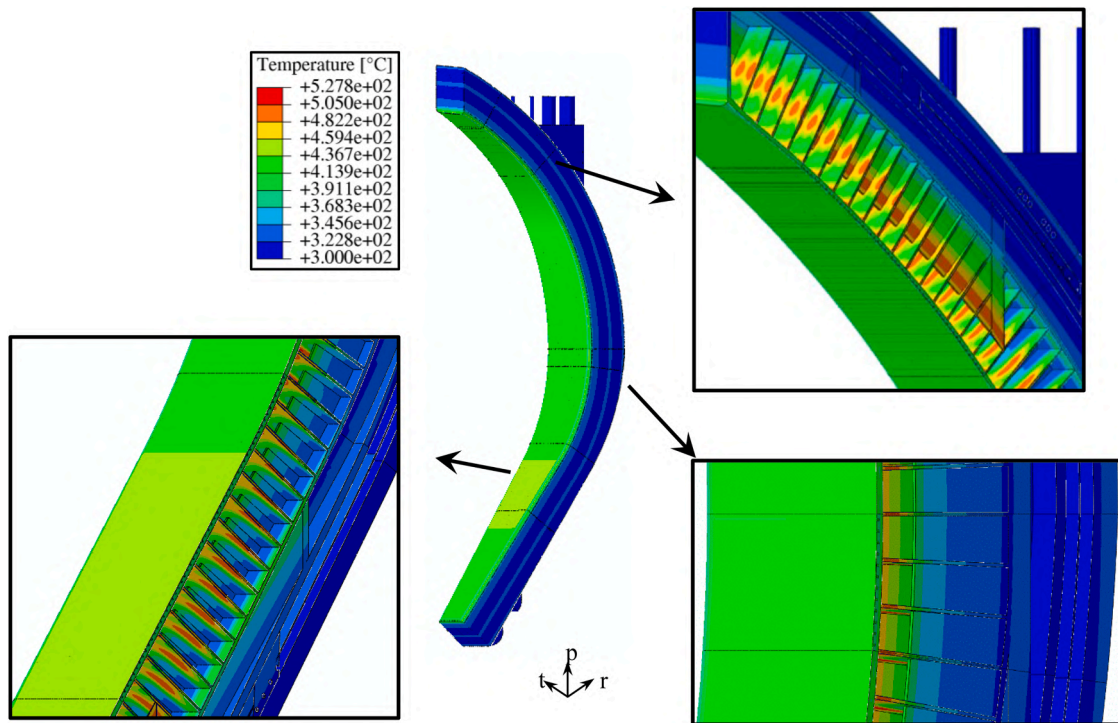

Fig. 6. Thermal field applied to the sub-models superimposed to the global model.

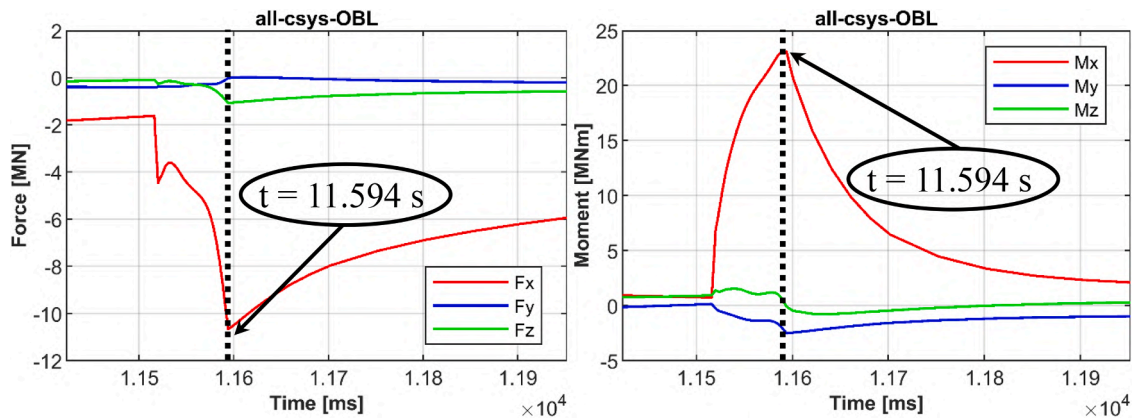

Fig. 7. Lorentz force and moment (with respect to the machine centre) vs. time in a UVDE [8].

Lorentz's forces at this timestep have been considered and applied to the three assessed regions [8]. The 3D spatial distributions of the EM loads have been included into the FEM models by means of a purposely developed computational procedure, as already done in [2].

Finally, the displacement field obtained from the structural analysis of the global model (namely the displacement field predicted for the LOB segment) has been mapped and imposed onto the upper and lower boundary surfaces of each sub-model, thanks to the application of the sub-modelling technique. The studies carried out in order to calculate such displacements fields are reported in [2], with a detailed description of the models and the boundary conditions adopted. In particular, for each loading scenario, the 3D spatial distribution of the displacement along x, y and z directions is mapped and applied to the nodes lying onto the upper and lower border surfaces of the three local models. In such a way, it is possible to consider the mechanical action of the entire segment on the assessed local region in all the loading scenarios simulated.

4. Results

Steady state analyses have been launched to investigate in detail the thermo-mechanical performances of each of the three regions of interest of the WCLL LOB segment under the considered loading scenarios. In Figs. 8–10, the Von Mises equivalent stress field obtained from the three sub-model analyses is reported, superimposed to the analogous field obtained from the analysis of the entire LOB segment [2], under the NO, OP and UVDE scenario respectively. In this way, it can be noticed that a good continuity is obtained in the 3D stress distribution, thanks to the application of the sub-modelling technique, between the results obtained in the local analysis and the global results obtained in [2]. Moreover, as the local sub-models are equipped with SB channels, a more detailed response can be predicted there. As already seen in global analysis, the central region experiences the highest stress as it is the most deformed region, as well as the lower transition region because of their closeness. Instead, regarding the upper transition region, lower stress is predicted since it experiences lower deformation. Thanks to the

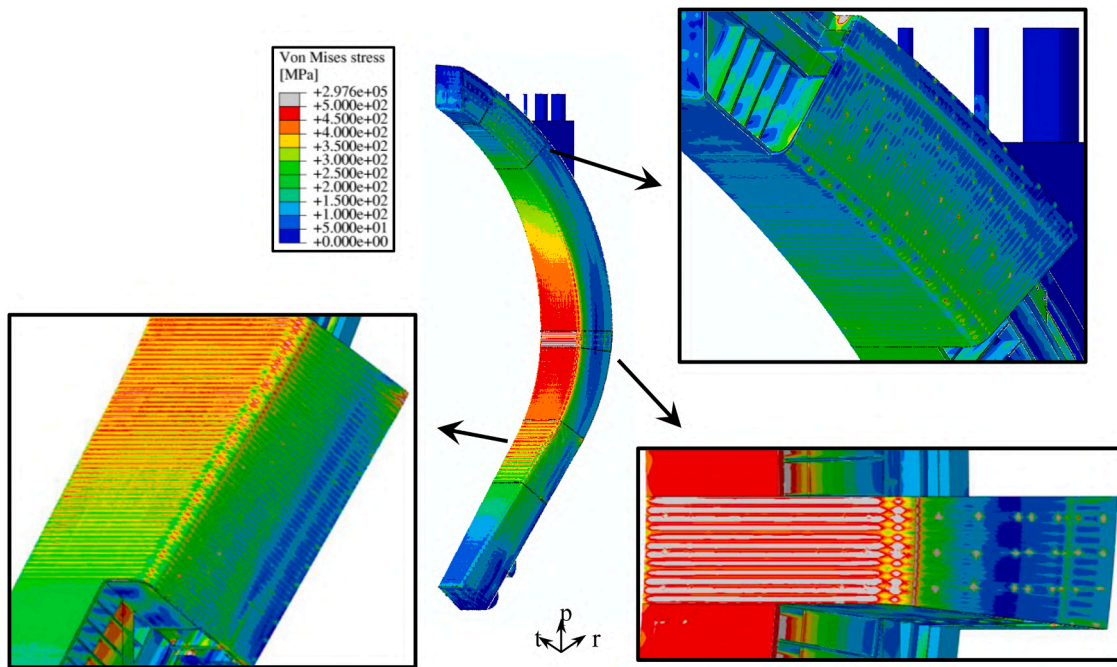

Fig. 8. Von Mises stress field under NO scenario on sub-models superimposed to the global model.

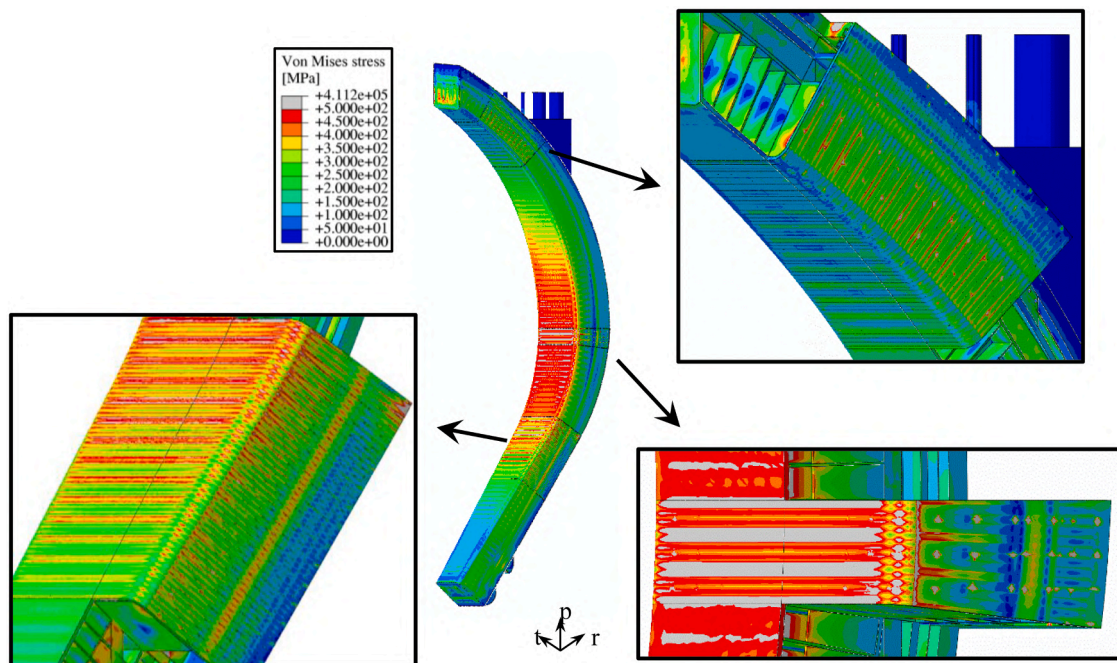

Fig. 9. Von Mises stress field under OP scenario on sub-models superimposed to the global model.

application of the sub-modelling technique, the SB region can be in-depth studied, unlike the global model analysis in which the structural response of this region cannot be analysed because of the cooling channels absence. Therefore, with the aim of checking the fulfilment of the RCC-MRx design criteria corresponding to the level of service A, C and D, a stress linearization procedure has been performed along some critical paths of the three sub-models. In particular, looking at the Von Mises equivalent stress distribution under all the assessed scenarios, some regions have been selected within the FW-SW region, nearby the cooling channels, and also within the vertical and horizontal SPs. The sets of paths selected within the three analysed regions are shown in

Figs. 11–15. It has to be observed that, regarding upper and lower transition regions, paths are selected at 4 different poloidal positions within FW. Whereas, within SPs, the paths have been selected carefully assessing the Von Mises spatial distribution. Lastly, it is important to highlight that those stress hot-spots mainly due to the EM loads applied as concentrated forces in the models, have been not considered as recommended by the RCC-MRx code.

Four RCC-MRx design criteria, each against a different damage mode (Immediate Excessive Deformation (IED), Immediate Plastic Instability (IPI), Immediate Plastic Flow Localization (IPFL) and Immediate Fracture due to exhaustion of ductility (IF)), have been selected to assess the

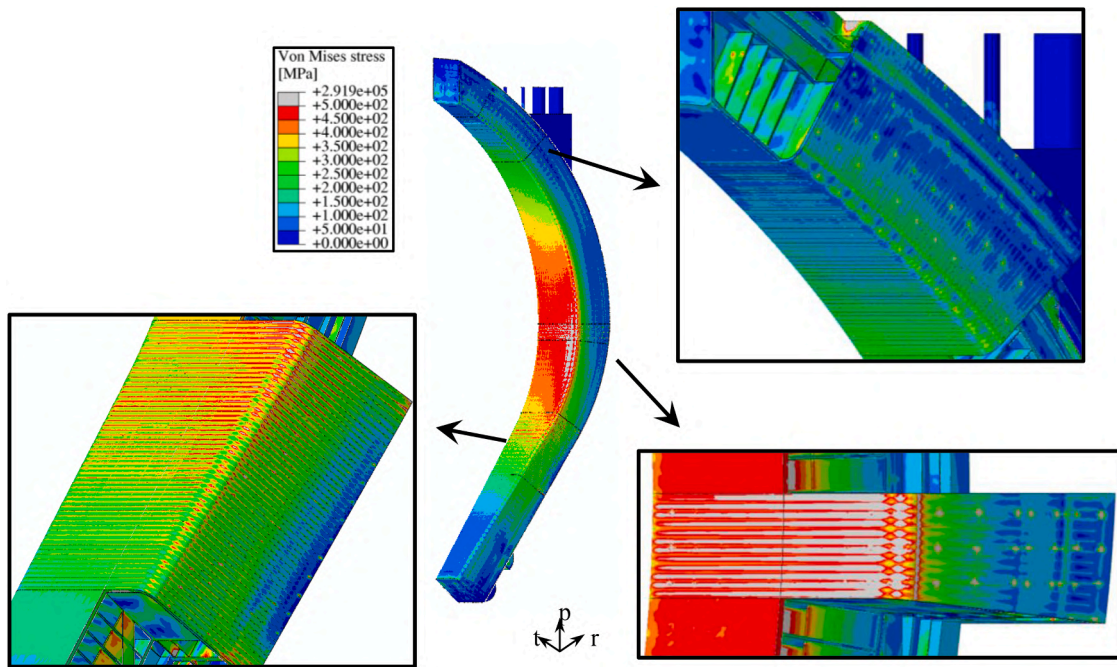

Fig. 10. Von Mises stress field under UVDE scenario on sub-models superimposed to the global model.

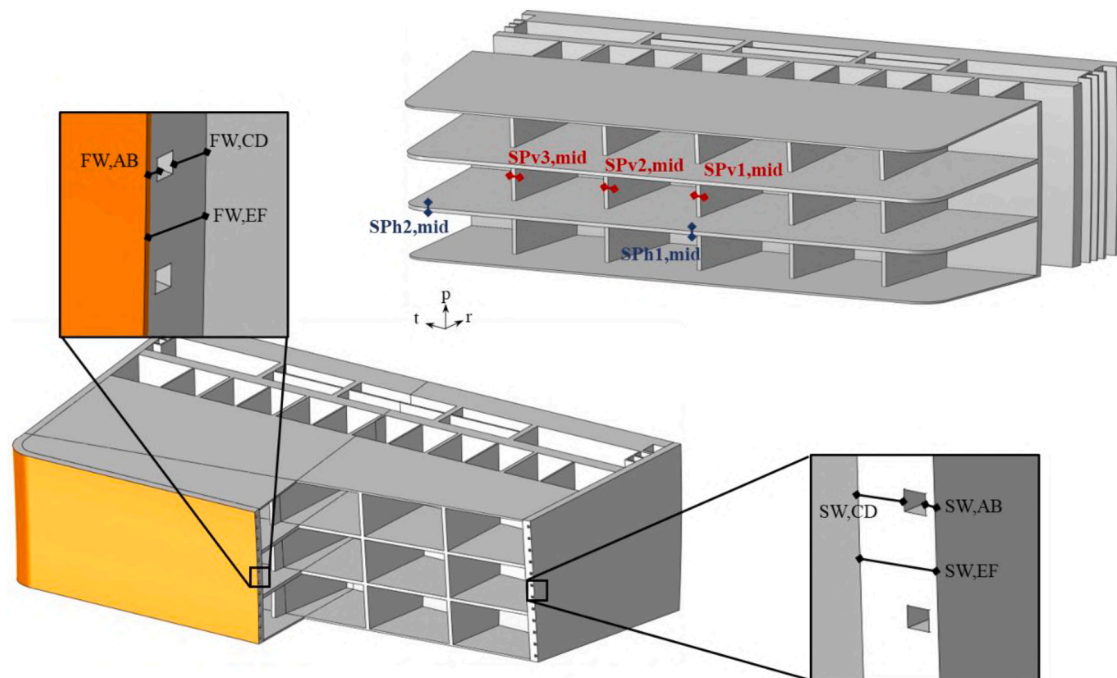

Fig. 11. Selected paths within FW-SW and SPs in the central region.

thermo-mechanical behaviour of the three analysed LOB regions under the load combinations relevant to the NO, OP and UVDE loading scenarios. The four criteria have been applied for the three service levels considering the pertinent stress limit.

In Table 3 the selected RCC-MRx criteria, in terms of ratio between the equivalent stress value and the corresponding stress limits, are reported. Values of the ratios greater than 1 indicate that the criterion is not fulfilled.

Looking at the stress linearization results of the central region (Fig. 16), the vertical SPs appear to be particularly stressed. In

particular, the path named “SPv2” do not fulfil the IPFL criterion, taking into account the secondary stress, in some case almost doubling the allowable stress value. Moreover, in the central region, also the path “SPv3” do not fulfil the same criterion. Globally, criteria are not totally satisfied along selected paths located due to the high deformation predicted in the central region. Moreover, in this region the three paths individuated within the FW and the path named “SW_AB” do not totally fulfil the IPFL criterion in all the assessed scenarios.

Regarding the upper transition region (Figs. 17 and 18), all the paths individuated within the SB largely fulfill all the selected criteria. Instead,

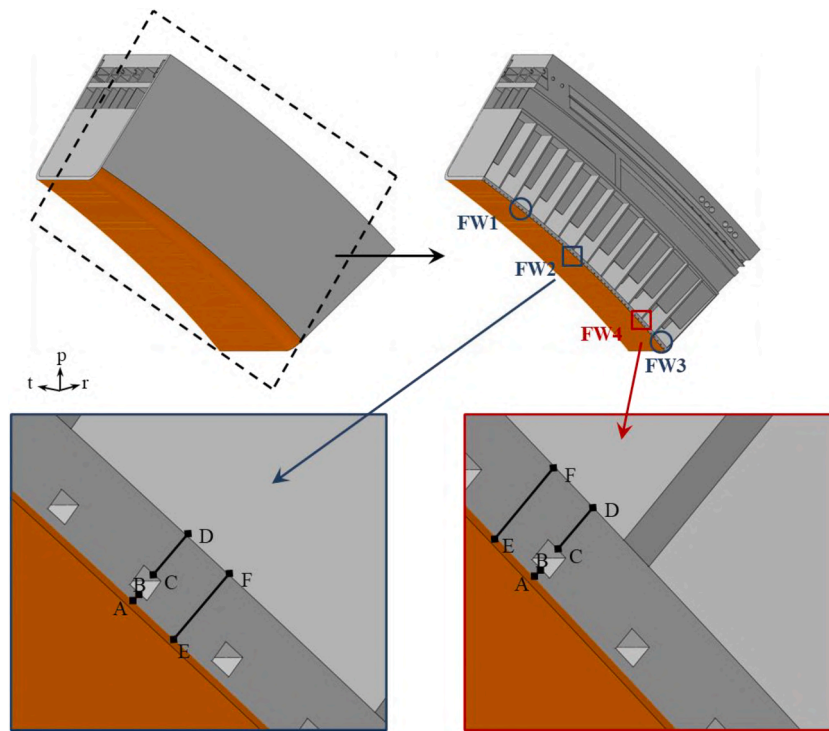

Fig. 12. Selected paths within FW-SW in the upper transition region.

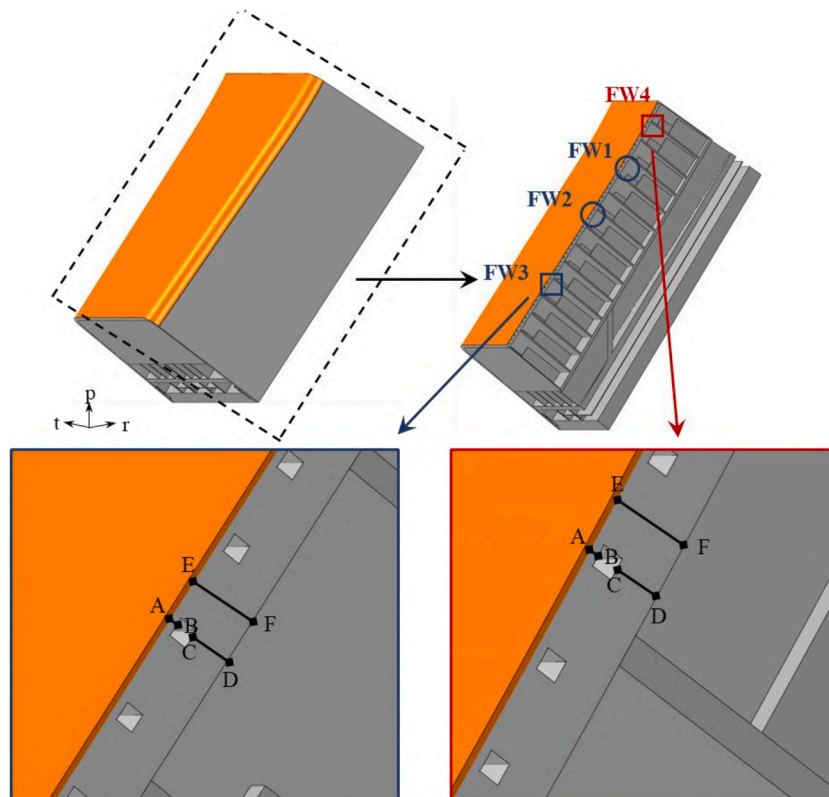

Fig. 13. Selected paths within FW-SW in the lower transition region.

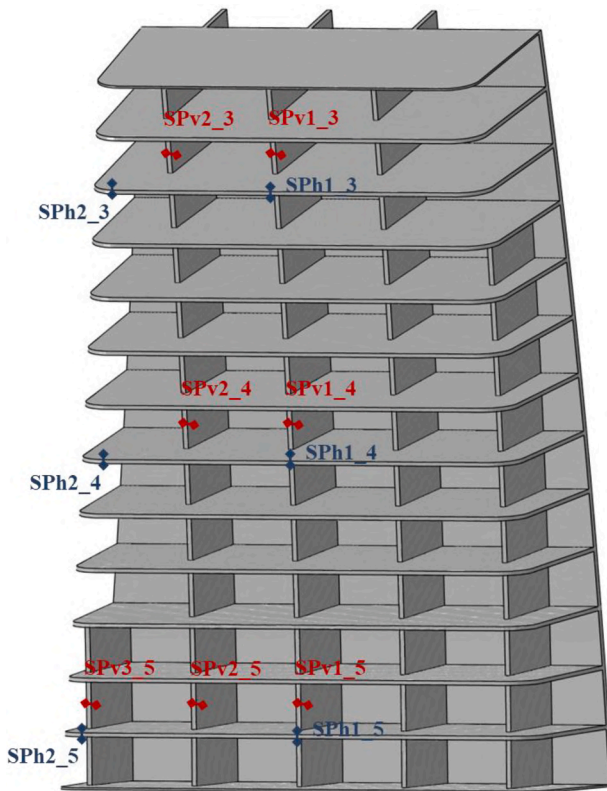

Fig. 14. Selected paths within SPs in the upper transition region.

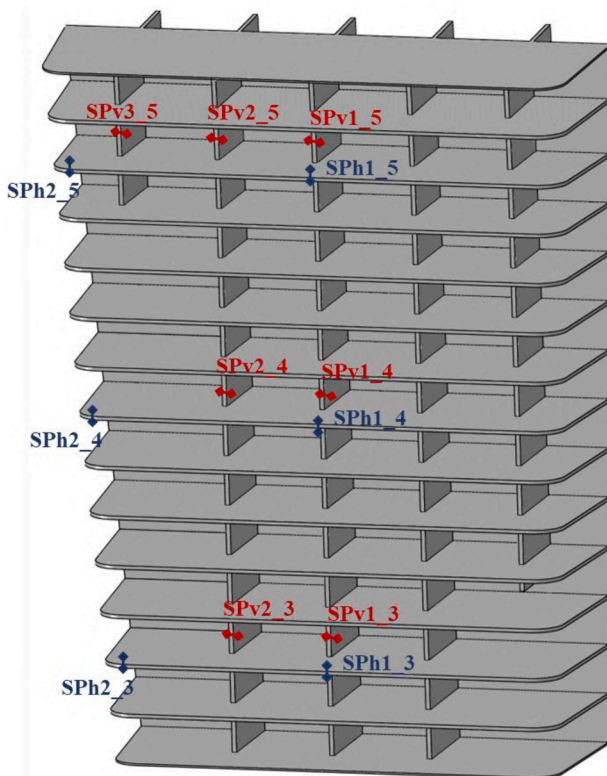

Fig. 15. Selected paths within SPs in the lower transition region.

Table 3
RCC-MRx design criteria.

Damage mode	Criterion
Immediate Excessive Deformation (IED)	$\frac{P_m}{S_{m,A-C-D}} < 1$
Immediate Plastic Instability (IPI)	$\frac{P_m + P_b}{K_{eff} \cdot S_{m,A-C-D}} < 1$
Immediate Plastic Flow Localization (IPFL)	$\frac{P_m + Q_m}{S_{em,A-C-D}} < 1$
Immediate Fracture due to exhaustion of ductility (IF)	$\frac{P_m + P_b + Q + F}{S_{et,A-C-D}} < 1$

two paths within the vertical SPs (namely “SPv2”) do not totally fulfil the IPFL criterion during the NO and UVDE loading scenario. This is mainly due to the fact that the SB experiences, in this region, a moderate deformation. Instead, the vertical SPs, are influenced by the high deformation experienced in the central region.

Lastly, in the lower transition region (Figs. 19 and 20), some paths do not fulfil the IPFL criterion, whereas all paths fulfil the other criteria. During the NO loading scenario, in fact, almost all the individuated paths do not fulfil the criterion or reach critical values (>0.8) of the ratio. A similar trend can be observed during the OP and the UVDE loading scenarios. This trend is due to the fact that the transition region at the bottom of the segment is globally affected by the large radial displacement occurring within its central region.

It is important to highlight that comparing the results of the verification of the RCC-MRx design criteria along the same paths within the horizontal and vertical SPs when the stresses are evaluated in the global model [2] and in the three sub-models, the same trend can be observed. This behaviour allows concluding that a sufficiently reliable structural evaluation can be attained from the global model analysis within the SPs region, despite the coarser mesh.

5. Conclusion

Within the framework of the EUROfusion activities, a research campaign has been carried out in order to investigate the detailed thermo-mechanical performances of some critical regions of the DEMO WCLL LOB segment under different steady state loading scenarios.

Thanks to the sub-modelling technique, allowing to take into account the structural behaviour of the entire structure, the thermo-mechanical performances of three regions of the WCLL LOB segment, namely the central one and two transition regions located in the upper and lower part of the segment, in which the vertical SPs change from three to five, have been investigated. In particular, the FW-SW region has been studied with a high level of detail by considering the proper cooling channels. The verification of the RCC-MRx criteria has allowed confirming the results obtained from the global analysis previously performed on the whole segment.

The most critical region is still the central one, both within the SPs and the FW-SW region, where a remarkable radial deformation arises due to the geometric layout of the attachment system. In addition, the transition region at the bottom of the LOB segment, being close to the central one, is more stressed than the corresponding region in the upper part of the segment. Results have confirmed, as already emerged from the structural analysis of the whole segment, that the attachment system should be revised in order to reduce the deformation field arising within the structure, which is the main responsible of the excessive stress predicted within the vertical SPs. Due to the same reason, RCC-MRx criteria are not fulfilled in some regions of the FW-SW complex.

Alternative strategies to mitigate the stress amount might be the increasing of the vertical SPs thickness and the reduction of the temperature in the structural components. Nevertheless, both the strategies could have negative impact under other standpoints (e.g. neutronics, balance of plant) so they should be carefully evaluated. Moreover further studies are expected in order to improve the adopted

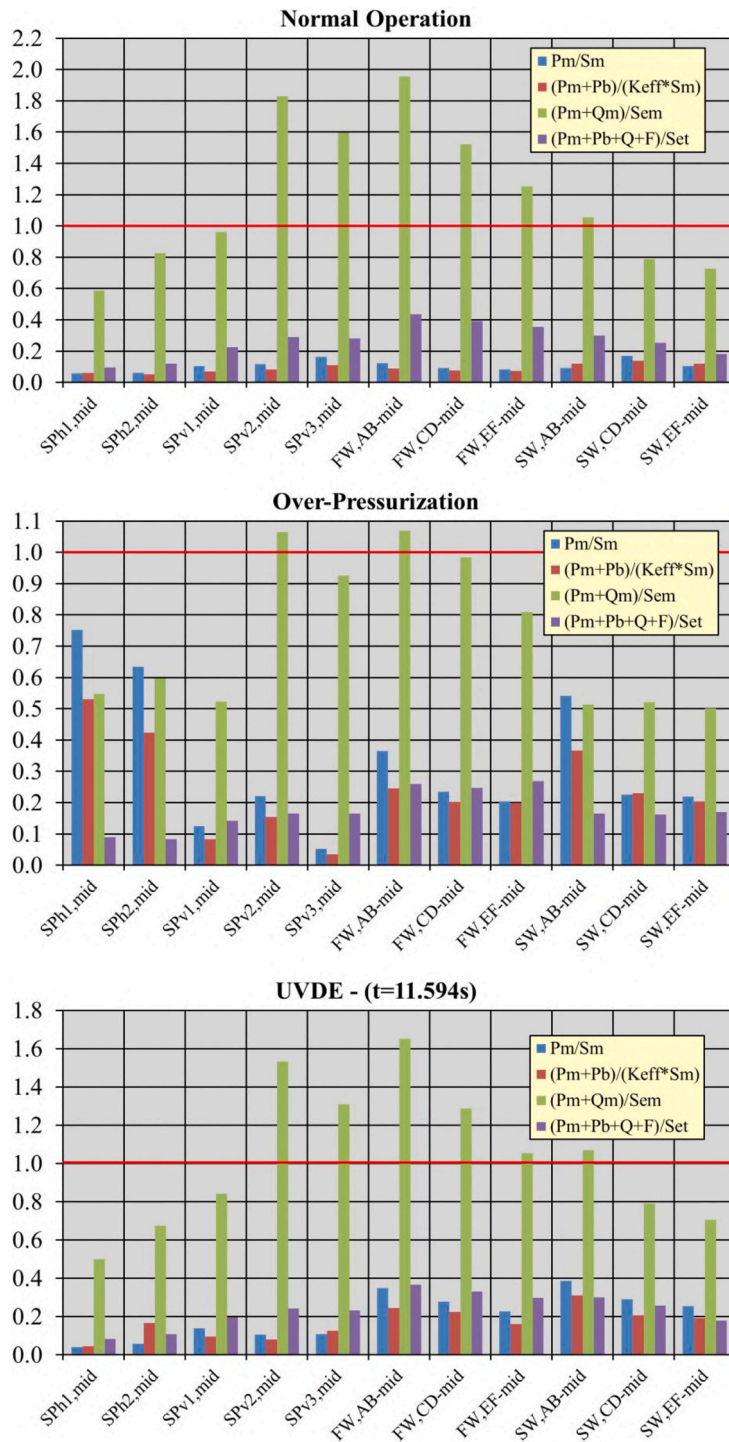

Fig. 16. RCC-MRx criteria verification within central region.

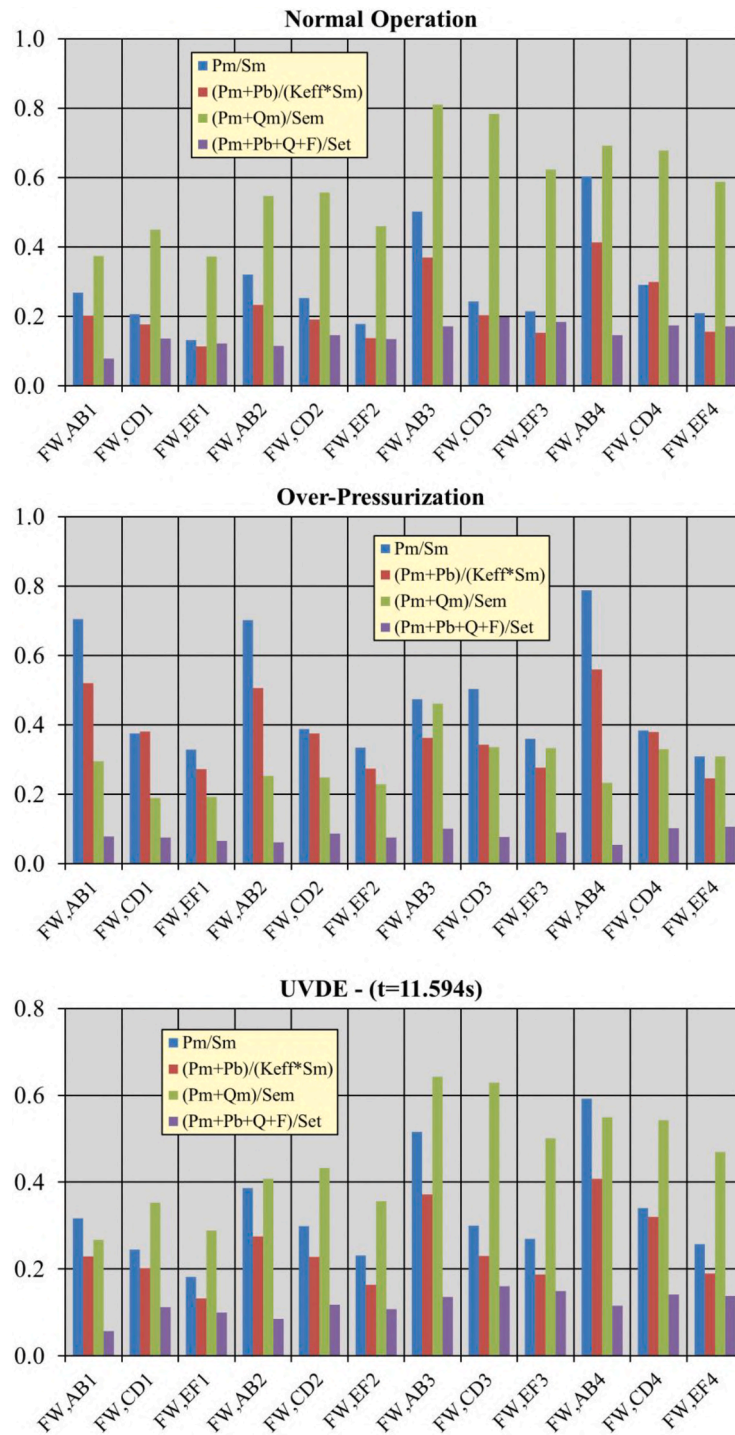

Fig. 17. RCC-MRx criteria verification in SB within upper transition region.

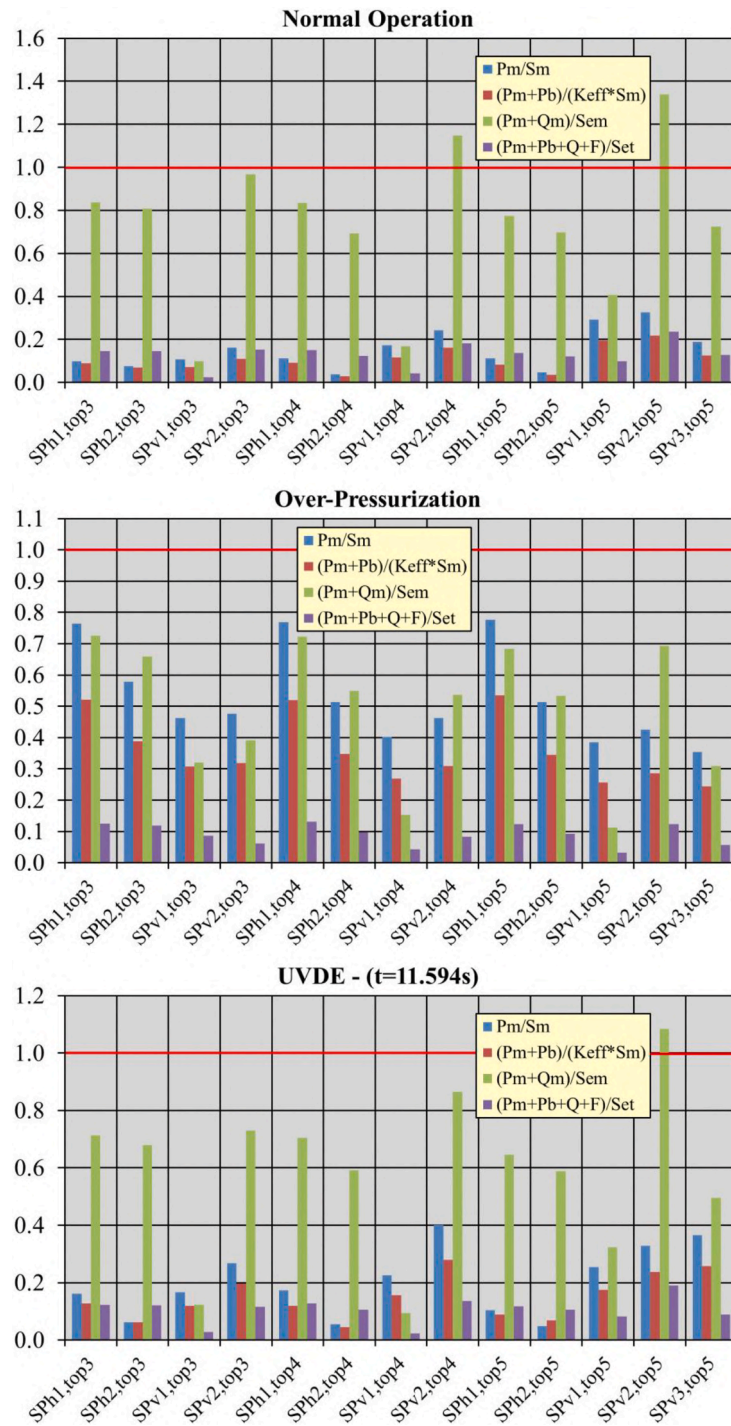

Fig. 18. RCC-MRx criteria verification in SPs within upper transition region.

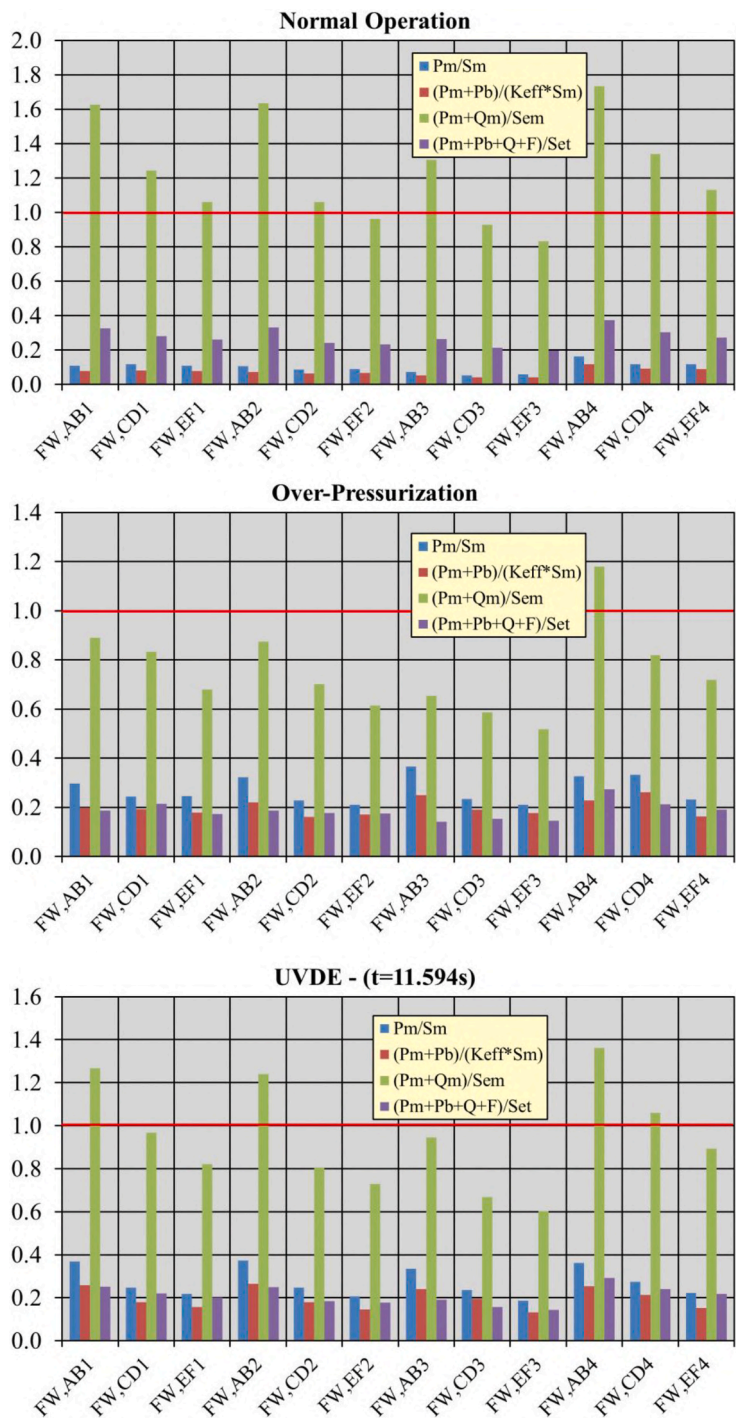

Fig. 19. RCC-MRx criteria verification in SB within lower transition region.

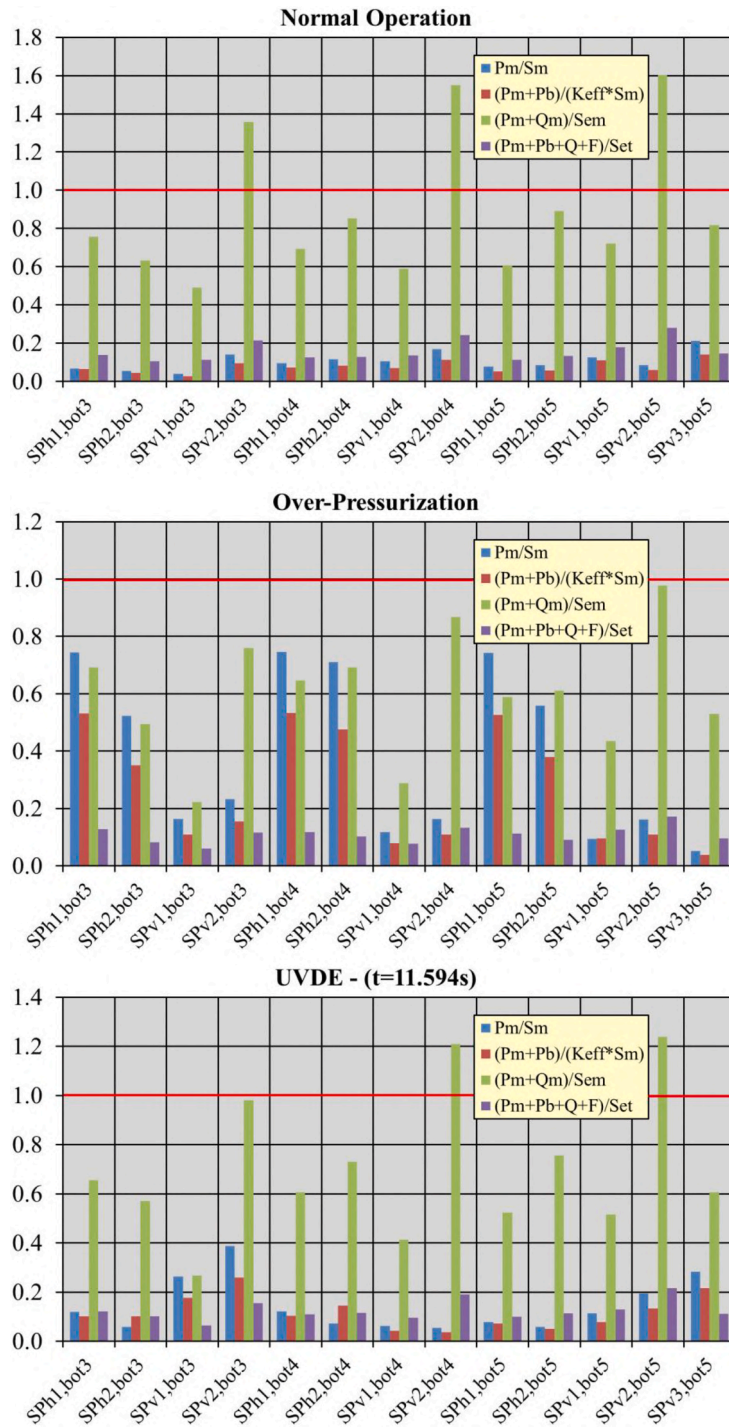

Fig. 20. RCC-MRx criteria verification in SPs within lower transition region.

methodologies and to consider more detailed loading conditions, focusing also on transient loading scenarios.

Declaration of Competing Interest

The authors declare that they have no known competing financial interests or personal relationships that could have appeared to influence the work reported in this paper.

Data availability

Data will be made available on request.

Acknowledgement

This work has been carried out within the framework of the EUROfusion Consortium, funded by the European Union via the Euratom Research and Training Programme (Grant Agreement No 101052200 — EUROfusion). Views and opinions expressed are however those of the author(s) only and do not necessarily reflect those of the European Union or the European Commission. Neither the European Union nor the European Commission can be held responsible for them.

References

- [1] L.V. Boccaccini, et al., Status of maturation of critical technologies and systems design: breeding blanket, *Fusion Eng. Des.* 179 (June 2022), 113116, <https://doi.org/10.1016/j.fusengdes.2022.113116>.
- [2] I. Catanzaro, et al., Preliminary thermal optimization and investigation of the overall structural behaviour of the EU-DEMO Water-Cooled Lead Lithium Left Outboard Blanket segment, *Fusion Eng. Des.* 184 (2022), 113294, <https://doi.org/10.1016/j.fusengdes.2022.113294>.
- [3] RCC-MRx, *Design and Construction Rules For Mechanical Components of Nuclear Installations*, AFCEN, Courbevoie, France, 2013.
- [4] Abaqus Analysis User's Guide: online Documentation; Version 6.14-2; Dassault System; Simulia: providence, RI, USA, 2015.
- [5] P. Arena, et al., The DEMO water-cooled lead-lithium breeding blanket: design status at the end of the preconceptual design phase, *Appl. Sci.* 11 (24) (2021) 11592, <https://doi.org/10.3390/app112411592>.
- [6] I. Catanzaro, et al., Development and application of an alternative modelling approach for the thermo-mechanical analysis of a DEMO Water-Cooled Lithium Lead Breeding Blanket Segment, *Fusion Eng. Des.* 180 (2022), 113195, <https://doi.org/10.1016/j.fusengdes.2022.113195>.
- [7] G.A. Spagnuolo, et al., Development of load specifications for the design of the breeding blanket system, *Fusion Eng. Des.* 157 (2020), 111657, <https://doi.org/10.1016/j.fusengdes.2020.111657>.
- [8] I.A. Maione, et al., A complete EM analysis of DEMO WCLL Breeding Blanket segments during VDE-up, *Fusion Eng. Design* 146 (2019) 198–202, <https://doi.org/10.1016/j.fusengdes.2018.12.017>.