

Journal for Architecture  
and Urbanism

English Version



# ARCHITECTURE

Legislating ARCHITECTURE

ST. LOUIS



“I would say a political program is more important  
than new rules  
or replacing rules with other rules.”

— REM KOOLHAAS



- 03 EDITORIAL  
*Anh-Linh Ngo*
- 05 PHOTO ESSAY  
*Christopher Roth*
- 09 LEGISLATING RELEASE /  
RELEASING LEGISLATION  
*Arno Brandlhuber  
and Christian Kerez  
in Conversation with  
Stephan Trüby*
- 14 LETTERS ON LEGAL  
ARCHITECTURE  
*Lucy Finchett-Maddock,  
Léopold Lambert*
- 22 POWER IS NOTHING  
WITHOUT CONTROL  
*Alex Lehnerer*
- Case STUDIES**
- 30 NEW YORK  
*Mirko Gatti, Alex Lehnerer*
- 36 LOS ANGELES  
*Alex Lehnerer*
- 40 LEARNING FROM  
ED RUSCHA  
*Martino Stierli*
- 46 LAS VEGAS  
*Alex Lehnerer*
- 48 THE SAN FRANCISCO  
BAY AREA IN  
THREE LEGAL CODES  
*Marcus Owens, Christina  
Antiporda  
(CAMO Projects)*
- 54 HOUSTON  
*Alex Lehnerer*
- 56 LAND USE IN  
THE UNZONED CITY  
*Matthew Festa*
- 58 ST. LOUIS  
*Colin Gordon*
- 62 SÃO PAULO  
*Marcos L. Rosa*
- 66 BUENOS AIRES  
*Jens Wolter*
- 70 TOKYO  
*Quang Tuan Ta*
- 72 TBILISI  
*Mariam Gegidze, David  
Manjavidze, Nicole Opel*
- 76 PARIS  
*Mirko Gatti,  
Alessandro Benetti*
- 80 LONDON  
*Katharina Kaufmann,  
Anh-Linh Ngo,  
Alex Lehnerer*
- 84 IF YOU BEHAVE LIKE  
AN IDIOT, YOU'VE GOT TO  
TAKE RESPONSIBILITY FOR IT!  
*Tom Emerson in  
Conversation with  
Arno Brandlhuber*
- 88 MUNICH  
*Martin Murrenhoff*
- 92 BERLIN  
*Katharina Kaufmann,  
Anh-Linh Ngo*
- 96 MISSED THE BOAT?  
*Andreas Geisel  
in Conversation with  
Arno Brandlhuber*
- 101 A LEGISLATIVE  
LEARNING PROCESS  
*Engelbert Lütke Daldrup  
in Conversation with  
Arno Brandlhuber*
- 106 "MORE CITY": WHAT IS THAT  
SUPPOSED TO MEAN?  
*Dieter Hoffmann-Axthelm  
in Conversation with  
Arno Brandlhuber*



Co-Editors: Arno Brandlhuber (AB), Tobias Hönig (TH) with Theresa Kraus (TK)  
ARCH+ Team: Nikolaus Kuhnert (NK), Anh-Linh Ngo (ALN), Mirko Gatti (MG),  
Tobias Gruber (TG), Max Kaldenhoff (MK), Katharina Kaufmann (KK), Rob Madole (RM),  
Sara Lusic-Alavanja (SAL), Stephan Redeker (SR), Achim Reese (AM), Christine Rüb (CR),  
Quang Tuan Ta (QT)

Cover photos: Basilicata, 2011, courtesy RaebervonStenglin, Sies+Höke and Peter Lav Gallery  
© Taiyo Onorato & Nico Krebs. Background above: © Jeff Roberson (p. 58). Background below: © Whitney Curtis

## Law CREATES Design

- 114 THE REGULATION, LAW,  
AND ETHICS OF  
ARCHITECTURE IN THE  
REFUGEE "CRISIS"  
*Niklas Maak*
- 118 PRIMACY OF THE MARKET:  
BUILDING REGULATIONS  
IN THE UNITED STATES  
*San-Hwan Lu*
- 120 LEGISLATION OF THE SEA:  
SPATIALIZING A  
NEW URBAN REALM  
*Nancy Couling*
- 124 A LEGISLATIVE SPACE  
KNOWN AS SWITZERLAND  
*Marc Angélil in Conversation  
with Arno Brandlhuber*
- 130 IT'S ALWAYS EASIER  
TO BE AGAINST SOMETHING  
*Adam Caruso in  
Conversation with  
Arno Brandlhuber*
- 136 STANDARD SIDE EFFECTS  
*Liam Ross*
- 146 LIFE UNZONED:  
PERSPECTIVES ON  
HYBRID URBANITY  
*Max Kaldenhoff,  
Anh-Linh Ngo*
- 152 THE GARDEN HOME  
*Imke Woelk*
- 155 HANDBOOK OF PERMIT-FREE  
BUILDING IN BERLIN  
*Matthias Spielvogel*
- 158 REDENSIFYING BERLIN'S  
BACKYARDS  
*Georg Augustin,  
Sebastian Ernst,  
Martin Tessarz, FAKT*
- 164 GENTLE ALIEN  
*Baukuh*
- 168 HOUSE WITH A LAKE VIEW  
*Christian Kerez*
- 174 THE FINE PRINT:  
A LEGISLATIVE CLOSE  
READING OF ARNO  
BRANDLHUBER'S WORK  
*Achim Reese*

## ARCH+ 50 features

Erica Overmeer  
on Brandlhuber+

## Design CREATES Law

- 184 7 + 1: DESIGNING  
THE MUNICIPALITY  
OF MONTE CARASSO  
*Luigi Snozzi in  
Conversation with Arno  
Brandlhuber, Waltraud  
Indrist, Christopher Roth*
- 188 CASA FLAVIO GUIDOTTI,  
CASE FRATELLI GUIDOTTI,  
CASA STEFANO GUIDOTTI  
*Luigi Snozzi*
- 192 WHERE EVERY CUBIC FOOT  
COUNTS: ON BROOKLYN'S  
MEZZANINE LOFT  
*Robert Scarano, Jr. in  
Conversation with Gabrielle  
Brainard and Jacob Reidel*
- 196 NO RECOURSE TO LAW  
*Anna Yeboah*
- 198 PRISHTINA,  
OR WHY LEGALIZATION  
MATTERS  
*Wilfried Hackenbroich,  
Kai Vöckler*
- 206 THE MAIFINITO  
PHENOMENON  
*Isabella Fera and Gaetano  
Licata in Conversation with  
Arno Brandlhuber*

- 214 RECETAS URBANAS:  
STRATEGIES FOR  
SUBVERSIVE OCCUPATION  
*Mirko Gatti*

- 218 SOME REGISTERS  
OF REGULATION  
*Nick Beech*

- 222 CONTRIBUTORS

- 224 IMPRINT



# THE Maifinito PHENOMENON

The architect Gaetano Licata, who once taught architecture at the University of Kassel, is now a professor in the Faculty of Architecture at the University of Palermo, where Isabella Fera is also on the academic staff. In 2014, Licata published the collection *Maifinito*, with editorial assistance by Fera. The book featured essays, projects, and a selection of “international artistic, social and architectural experiences,” all of which centered around the “*fenomeno del maifinito*,”<sup>1</sup> the *maifinito* phenomenon—in other words, the enormous number of unfinished buildings in southern Italy, and especially on the island of Sicily. Many of these buildings, so-called *maifiniti*, have been constructed entirely outside the legislative framework—a phenomenon that perfectly encapsulates the relationship in Italy between construction, the public vs. private realm, the state, and legislation.

In December 2015, Arno Brandlhuber met Isabella Fera in Palermo for a wide-ranging discussion. Afterward, he traveled to the south of Sicily to converse with Gaetano Licata in a building he rebuilt, the Santa Barbara Hospital in Gela.<sup>2</sup>

CONFESSION, FORGIVENESS, AND HEALING: “CONDONI” AND “SANATORIA”  
*Isabella Fera* in Conversation with *Arno Brandlhuber*

**Arno Brandlhuber:** Isabella, your contribution to the book is something of a glossary: ‘Maifinito in 32 parole’—‘*maifinito* in 32 words.’<sup>3</sup> In it, you write that the Italian word *abusivismo* is untranslatable.

**Isabella Fera:** The word ‘abuse’ exists in English. But there’s simply no equivalent, in any other language that I can think of, for the term *abusivismo*, which means illegal or extralegal building—buildings that abuse the law. Maybe it’s only because other languages don’t deem it necessary to set aside a specific term for this, as a general phenomenon. Even where the practice is fairly widespread, there’s no term for it. But it’s not limited to southern Italy. You can also find examples of *abusivismo* throughout Italy and in many Mediterranean countries—in South America as well. Maybe it’s a sign of a different cultural approach.

**AB:** What are we supposed to imagine when we hear the word *abusivismo*?

**IF:** The idea that comes to mind is a huge quantity of unregulated buildings, and of people on the very thin line that divides legal from illegal construction. There’s a fair amount of tolerance for *abusivismo*—large swathes of the population even sympathize with the practice—but there’s also a rising feeling that this behavior becomes a burden for the whole of society, and that such illegal activities should be considered a crime.

**AB:** What role does the family play in this?

**IF:** The family plays a key role in the unfinished buildings, considering they often result from a family’s failed attempts at planning for the future. A family might build a couple of extra floors so the whole family can live in a single building. But the children decide to move away, siblings don’t get along. Or children don’t share their parent’s vision, so they decide to lead their own lives in other places. Expectations go unrealized, and the buildings come to symbolize that.

**AB:** Could this mean that the *maifinito* is founded in the idea of the traditional family?

**IF:** In traditional families, you see a tendency to keep everyone in close proximity. But today the opposite is happening. Nowadays, even a husband and wife sometimes live in different places. The whole notion of the building as a family nest is a thing of the past.

**AB:** Are there any political solutions for the phenomenon? By bringing up the issue of legality, you’re alluding to two different legislative attempts to deal with the *maifiniti*.

**IF:** In Reggio Calabria, new laws were passed to address the enormous amount of unfinished family houses. They tried to carry out a survey to assess the extent of the phenomenon and take action on the basis of the survey. In Sardinia, a law was drafted in 2010 to grant 25 million euros toward completing unfinished houses.<sup>4</sup>

**AB:** In your essay you write that planning is, by definition, a political act.

**IF:** Of course planning is strictly linked to politics. But the topic of *abusivismo* also comes up during every electoral campaign. People want to regularize, to legalize their buildings. They want amnesty for their illegal and unfinished buildings. Some people need permissions, others simply want to build more and the current law won’t allow them to. And then there are people who aren’t allowed to build on their property at all. The attention politicians pay to this phenomenon is often tied to specific promises—and you can see, the *maifinito* themselves come to symbolize broken promises as well.

**AB:** Who is Cetto La Qualunque?

**IF:** He’s a character played by the Italian comedian Antonio Albanese—a very bad politician who combines all the worst aspects of politicians in southern Italy. He gives speeches onstage, while behind him, in the background, you can always see unfinished buildings. This alludes to the fact that *abusivismo* owners are really seen as a source of votes for this kind of politician—they promise to legalize these abuses, to eventually have new buildings allowed where it’s currently forbidden.

**AB:** So that’s what the *sanatoria* acts<sup>5</sup> were all about?

**IF:** Pretty much. *Sanatoria* is a word that describes amnesty for violations that have been discovered. For many people, it’s one of the main promises they expect from political campaigns.



Unfinished building, Sicily

The same applies to the so-called *condoni*, which are literally gifts—they make it possible for you to have permission granted by just paying a fine. The word *sanatoria* refers to an ill body, so it amounts to an act of healing—an act of healing, of course, that never actually happens. The only healing actually happening is that the house is no longer illegal. But the whole phenomenon, this enormous quantity of illegal buildings, and the fact that they’ve been built maybe at the wrong geographical spot, or maybe near an ancient ruin—none of this is cured by just paying a fine.

**AB:** You pay and your sins are forgiven. It’s very Catholic.

**IF:** Similar to indulgences, yes. Paradoxically, some people use *sanatoria* like building permissions. For example, if one of these *condoni* is announced, people will ask for *sanatoria* for buildings they haven’t even built yet.

**AB:** So they pay for a sin they’re going to commit in the future?

**IF:** Exactly. You ask for forgiveness before you sin.

**AB:** I’m Catholic myself. When I had to go to confession, I’d always invent sins, just to fulfill what was expected of me. Yet to confess to something that you’re going to do wrong in the future—to me, that seems like a very advanced way of thinking.

**IF:** It’s very strategic, and undoubtedly it necessitates a certain degree of advanced planning skills. Unfortunately, it’s a talent mostly being applied toward the wrong goals. Of course, it’s not just a local phenomenon that everyone is trying to achieve the best outcome for themselves—to build the most possible, and earn the most money possible. But in most countries, there’s still a cultural system, and a system of law, that prevents you from circumventing certain boundaries. In Italy, boundaries are sometimes very loose. So things can go very wrong.

**AB:** How could you entirely reshuffle, reinvent the social or communal aspects of the problem?

**IF:** You know, people often see the public realm as their enemy. There’s a lack of space, a lack of services, and this leads to a particular form of compensating—people grab and take without asking.

**AB:** I’ve noticed that people here simply throw their rubbish out on the streets—but inside people’s houses, it’s usually very proper, very orderly.

**IF:** Exactly—you’ll see houses that don’t have any plaster on the outside, every window is entirely mismatched, and there’s garbage strewn all across the front yard. But when you walk inside, everything’s very clean, sometimes incredibly ornate. I would say that comes from a sick relationship with the public life, with a state that feels as if it’s foreign, as if it only wants to *take* from you. Meanwhile, we all just want to live a happy life and do what we want, on our own plot of land.

BRINGING THE PATIENT BACK TO LIFE: “REANIMATION” AND “AGENCY”  
*Gaetano Licata* in Conversation with *Arno Brandlhuber*

**AB:** Gaetano, when talking about the *maifinito* phenomenon, Isabella Fera spoke about a sick body that needs healing. Now we’re sitting together in a hospital that you’ve rebuilt.

**Gaetano Licata:** That’s just a coincidence. When we first began grappling with this whole phenomenon, I challenged my students to think of the *maifiniti* anatomically, to conceive of them as dead people in the Sicilian landscape. Like their fellow students in the medical department, they could perform experiments directly on the inanimate bodies: everything is open, visible; everything can be touched and measured. But after performing an autopsy on a *maifinito*, you have a chance to think about how to *overcome* death, and bring the patient back to life.

**AB:** Do you look at the *sanatoria* as a state-sponsored resurrection technology?

**GL:** No. The *sanatoria* make it possible for a building to transition from illegal status to legal status. They don’t stipulate what that’s meant to accomplish—what prerequisites a building must fulfill to meet social challenges, social aims. In the end, they’re just about having money transferred to the state.

**AB:** If it’s not a cure or a resurrection, is it more like the selling of an indulgence?

**GL:** Well, the obvious tack is to explain it as a Catholic phenomenon. But I think the whole problem is underpinned by a false understanding of the public realm: ‘The public realm belongs to everybody; what belongs to everybody belongs to nobody. That means I can take it for myself.’

**AB:** In other words, while the state is doling out top-down indulgences, at the same time it’s fostering these illegal, bottom-up strategies. And these strategies themselves can be traced back to issues like the state’s failed building policy.



# Legalizing Reality

**GL:** Exactly. People say to themselves: ‘If the state won’t build for us, we’ll build for ourselves.’ A lot of what then results is illegal. And because of the failed building policy, there’s also not enough models of *contemporary* construction. So not only are the building typologies reduced to a bare minimum—they’re also entirely antiquated. Another realm where the state has failed is spatial planning. When you have municipalities without a land-use plan, you open up gray zones, which become fertile soil for *maifiniti*. A lot of people have no idea who they’re supposed to contact in the bureaucracy when it comes to construction questions. So a lack of planning and a lack of control results in tolerance, which amounts to something like freedom. But to use this latitude, this freedom, productively, we need to distance ourselves from the discussion about the legal and moral status of the *maifiniti*, and instead start thinking in precise terms about the positive outcomes we can extract from the phenomenon.

**AB:** I would say there’s a certain creative potential. For example, the light-frame roof canopies in Gela.

**GL:** Well, it’s true, the residents of Gela have invented an entirely new building type to get around the rules. The new mayor understood the problems posed by the rampant illegal buildings his citizens were constructing, so he decided to take satellite photos of his municipality on a regular basis. Using these, he could spot new construction sites. But the people of Gela were quicker on the uptake—they started building these roof canopies to obscure their mayor’s satellite view, in order to set space aside for later projects.

**AB:** In a way, you could say the mayor has awakened his community’s inventive spirit.

**GL:** I don’t think he had that in mind. Since then, this mayor, Rosario Crocetta, has become the president of Sicily and a member of the European Parliament. But he’s never been able to attend a session, because they can’t guarantee the security measures necessary for an openly gay communist who’s declared war on the Mafia. For him, it has always been about bringing these processes back into a regulated sphere, and he considers satellite surveillance a good instrument for that. But you have to catch people red-handed.

I mean, undoubtedly these people are displaying a lot of resourcefulness. But experiments like this become model behaviors. You can try to see it in a positive light, and get excited about certain unique typologies, about the possibilities they offer. But it’s too easy to copy these ideas, and the copies then spread out incredibly fast across the whole island.

**AB:** You’ve written that *communicating* the current condition of the buildings is far more important than drawing up new laws.

**GL:** Look. Entire neighborhoods have been built according to misguided rules—and then people have gone and broken these rules. You can’t just return to ‘normal,’ lawful status by writing new laws. The *sanatoria* and *condoni* have already failed trying to do this. A lot of the housing stock was built more than 30 years ago. The areas around the buildings have changed, the buildings themselves are perpetually ‘in progress.’ When I say we need communication, what I mean is that someone needs to describe the challenges this has created. You have to acknowledge that building is a strategic process, an ongoing process—it’s

not about thinking something up, and right off the bat it’s nice and pretty. It doesn’t make any sense to conceive of the *maifiniti* in land-use terms and two-dimensional planning terms.

**AB:** Who should perform this task of communicating? The state has already tried the legislative approach, and it hasn’t worked. So the state’s out of the game.

**GL:** You could try putting the *maifiniti* in the hands of architects and urban planners, who could then develop new models for these buildings and clusters. For some of them, there’s no hope of ever being legalized through *sanatoria*—for example, buildings that aren’t less than 150 meters from the coastline. At the moment, it seems like there are only two options: look away, or tear them down. This is precisely where I see the potential of communication: can these buildings be saved? Possibly even for the sake of the people who trespassed the law? By making them public, perhaps?

But above all, it’s the task of the municipalities—the same municipalities under whom the existing rules were violated, and who didn’t use the legislative instruments they had available to them. Even as co-perpetrators of this phenomenon, they need to be in a position to imagine a future where the *maifiniti* are integrated. They need to make amends. This isn’t happening at the moment—not so much because our state is so corrupt, but because it doesn’t have any access to the phenomenon. The state simply isn’t in a position to comprehend, to describe what is happening before its eyes—and from there, to understand the phenomenon, and as a result, to formulate a question that could be used to develop instruments with which to act.

In the future, they want to intervene—to offer subsidies if construction is halted and the building is torn down. So it’s like how they told our fishermen, when tuna were being over-fished: ‘If you keep your boat on land, you’ll get money in compensation.’ But subsidies also encourage partial teardowns, and in many cases people ultimately manage to build even more, quantitatively speaking. So these specific approaches need to be communicated, but first and foremost, we need to keep the number of new *maifiniti* low. To provoke people to negotiate, you first have to exert some pressure. Otherwise it all remains blocked.

**AB:** In a way, though, the *maifiniti* are the opposite of blocked. They’re perpetually unfinished—a circumstance we know well from our own lives. In this respect, the *maifinito* are a perfect reflection of our present-day culture.

**GL:** It would be exciting to think of buildings for an entire lifetime. Today, the code says: ‘Your building permit is valid for three years. If you’re not finished by then, you need a new application.’ But we should have rules that allow buildings to be rethought, to be expanded over longer periods. People often ask me, ‘How many of these Dom-ino houses do you have in Sicily?’ I don’t think the Dom-ino concept is so off-base. It evokes something like a pre-typological visual; it’s the perfect basis for this way of thinking—I just need floors, beams, and I can already move here and there, back and forth!

**AB:** How many of these Dom-ino houses—sorry, *maifinito* buildings—are there on Sicily then?

**GL:** People have tried to count. Let’s just say there’s a lot. A whole lot.

1 Gaetano Licata, ed., *Maifinito* (Macerata: Quodlibet Studio, 2014).  
 2 The interviews were transcribed and edited by Tobias Hönig and Theresa Kraus.  
 3 Isabella Fera, “Maifinito in 32 parole,” in Licata, *Maifinito*, 30–39 (Italian), 130–136 (English).  
 4 The “Piano Casa” law passed by the Berlusconi regime stipulated that owners could enlarge the volume of their buildings by 20 to 30 percent if they renovated them entirely. Even 35 percent enlargement was allowed if the building was torn down and entirely rebuilt using environmentally friendly materials. The individual regions of Italy were entrusted to implement the “Piano Casa” laws themselves, and some also used the opportunity to support anti-seismic measures in earthquake regions.  
 TH  
 5 In 1985, under the Craxi administration, the first so-called *condono edilizio*, an amnesty law for illegal buildings, was announced. The law described, in precise terms, which building-code violations could be “healed” within a fixed amnesty period by paying a fine. On two more occasions, in 1995 and 2003, the Dini and Berlusconi administrations passed similar *condono edilizio*. These laws set up specific amnesty periods; outside these timeframes, building-code violations could only be “healed” via so-called *sanatoria*. This sort of “healing” can only be approved for a building constructed without permission if the building, in principle, meets the codes in force at the time the rule was broken.

© Isabella Fera & Michele M. Cammarata

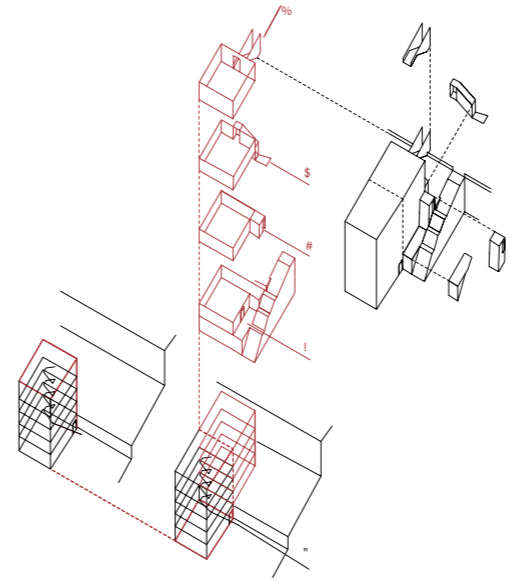

Axonometric view

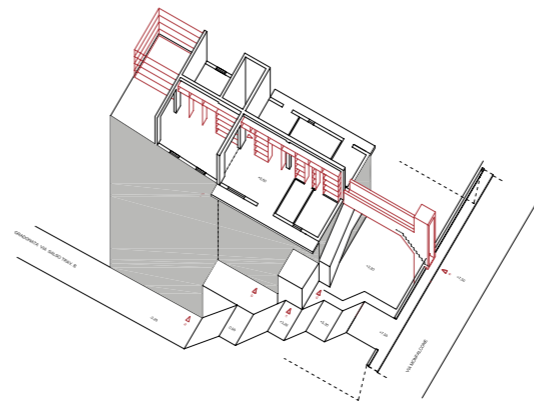

Provocative proposal to construct a bridge entrance to the illegal rooftop extension

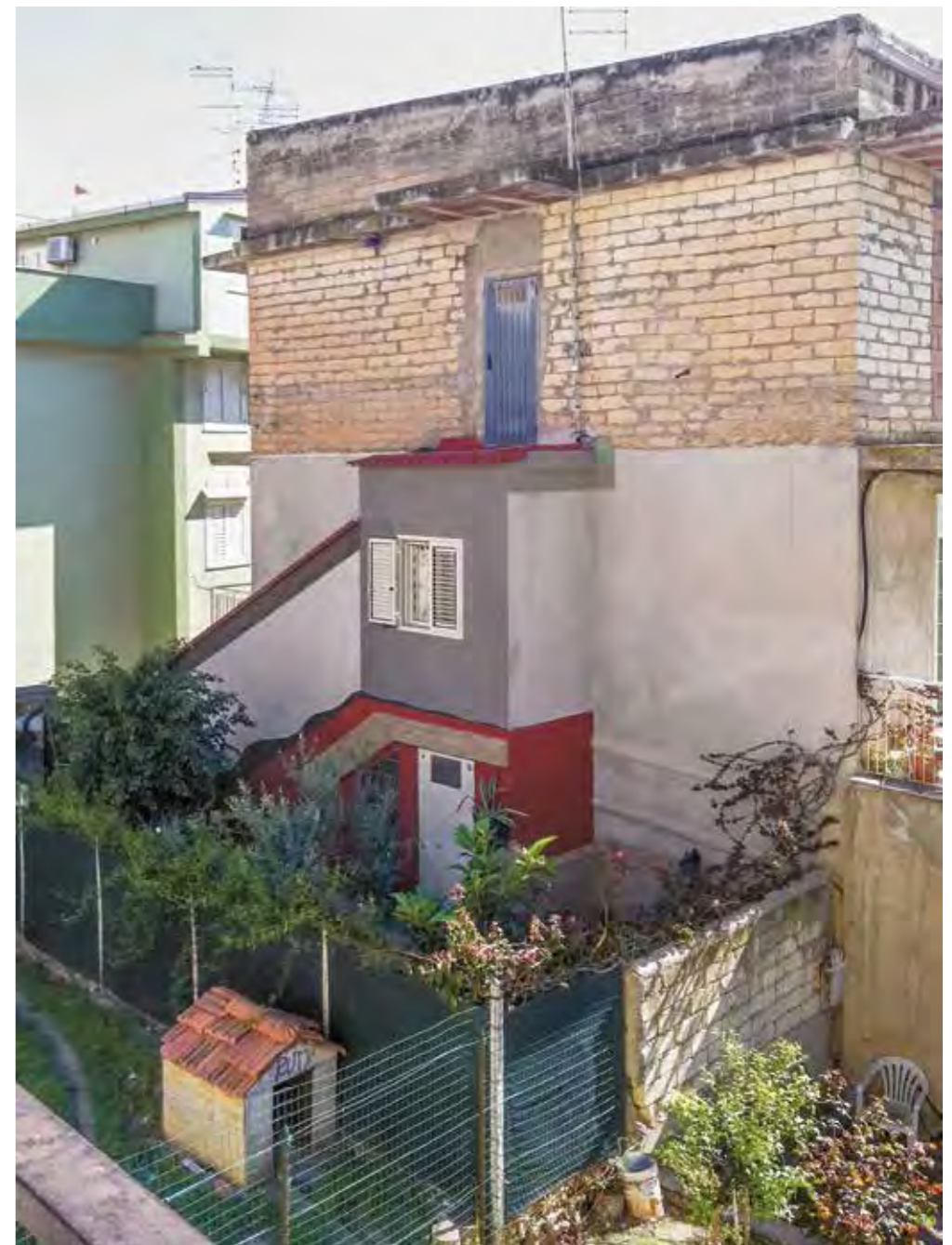

A multi-generational family house. Each unit has its own illegal independent entrance.

## Everybody for Themselves LICATA, PROVINCE OF AGRIGENTO

As a *maifinito* building evolves in Licata, a family’s domestic life works together with a complex vertical arrangement to pay witness to plans that never come to fruition, the emergence of unforeseen circumstances, and continual transformation. The construction of urban infrastructure—which, in an inversion of the usual timeframe, was completed after the building’s structure had already been finished—played a key role in this tangled evolutionary web. Originally built in partial violation of the law, the building today has been entirely *regularized*, taking advantage of various regularization procedures available for illegal structures. The building was originally designed as a block of flats for a single family, featuring

a shared entrance and a communal staircase leading up to the individual flats on different floors. A symmetrical block of flats was built onto the structure later, its floors at the same height as the adjacent block, thus serving to double the number of people using the same entrance and staircase. But when public stairs were built along the side of the building at a tangent, linking its upper and lower parts, the inhabitants of the second block were given an opportunity to construct their own entryway. Each of the owners obtained their own private entrance by adding stairwells that attached to the landings of the public steps. This gave rise to a new kind of “tower block,” with lots of “ground floor”

flats, entirely independent yet stacked atop each other. When an effort was made to finish constructing the unfinished apartment on the top floor, the strategy of creating independent units atop each other was used again. A staircase/bridge enabled private access to the top floor, this time reached from the highest part of the slope, turning the fifth floor into a mezzanine level. The project, eventually extended to include the neighbouring flat on the same floor, was undertaken because a member of the family who had emigrated to Germany was due to return home to Licata. In the end no one came!



# Legalizing Reality

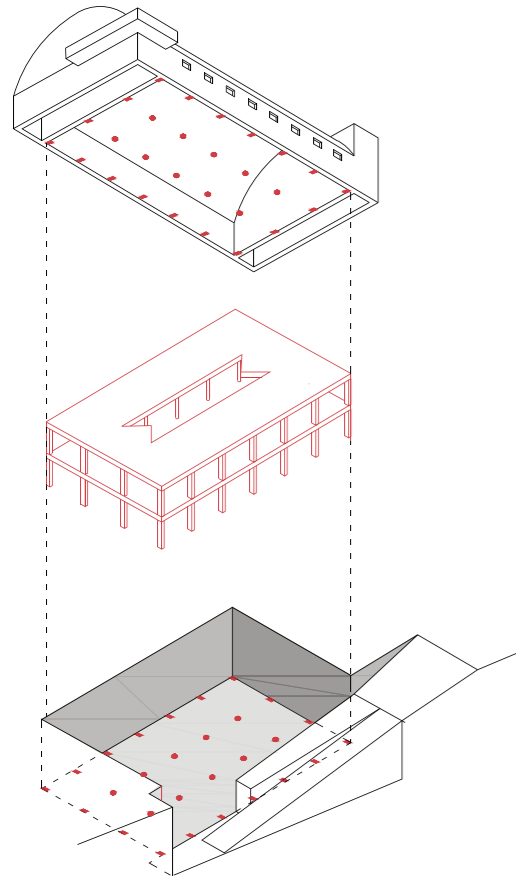

Axonometric view



© Emanuele Leggio



© Emanuele Leggio

An underground excavation constructed secretly underneath an abandoned building

## Built from Within RAGUSA, PROVINCE OF RAGUSA

This remarkable *maifinito* building, practically invisible from the outside, is an unusual example of how these unfinished buildings can fully express one of architecture's most recurrent themes: the relationship between inside and outside, between contents and shell, between what we can see and what we can't see. After years of abandonment and neglect, an attempt was made to bring this building back to life—an attempt that was abandoned halfway through. The original structure dates back to around 1960, when it was built as a production factory

for cement flooring in an industrial area of Ragusa that never really got off the ground. After the initial factory shut down and the site was abandoned, a team, apparently working in secret, built another structure over four levels tall inside the old shell, which was otherwise left in its original state. The building was envisioned as a commercial space to store, display, and sell electric appliances. Both stages of the building's lifespan are visible today, suspended halfway between initiation and realization. A large ramp was built to provide

access for trucks that had to crawl like moles down into the existing building. Did the builders plan, later, to demolish the volume above? Beyond not attracting attention, this construction method also took advantage of the fact that, as a general rule, planning regulations set no limits on underground volume, as if it doesn't even exist. Continuing or completing this building today would be a highly complicated process, if anyone actually deemed it worthy of their time. Irrespective of what might or might not be authorized, where would the real

value of this building lie? Where does it derive its essential qualities—from the new work carried out inside, or the original building on the exterior? Or perhaps, instead, from the space created by the two of them in concert? Are its true elevations those of the old warehouse, or the new hidden interiors which—sooner or later, had the shell ever opened up and exposed them to the world, like a sort of magic trick—would suddenly have become exteriors?<sup>2</sup>

## Skeleton Garden ACI CASTELLO, PROVINCE OF CATANIA

On one of Aci Castello's main streets, there sits a *maifinito* building that, over the years, has been entirely covered by ivy growing in the neighboring garden. As a result, the *maifinito*'s most inalcitrant aspect, namely its structure, has vanished, transforming into an oversized support for the vegetation while simultaneously giving rise to a vertical garden over several levels. Not only does this structure result in vertical facades, a feature very much in vogue today, but also functions to truly multiply the ground over all the building's different floors. The fortuitous growth, in addition to softening the stark visual impression typically left by these buildings (especially in dense built environments), also demonstrates how *maifinito* can undergo a variety of different stages, taking on several different appearances over time with little or no investment needed, thanks to an event as spontaneous as a shoot of ivy. The vegetation can serve to camouflage the nudity of these buildings, which might

otherwise be destined to remain bare for years on end. It enables them to change with the seasons, with the different flowers and vegetation, while also remaining temporary—at least until the next transformation arrives sooner or later, or never ... part of the reversible condition that is part and parcel of being a *maifinito*.<sup>3</sup>

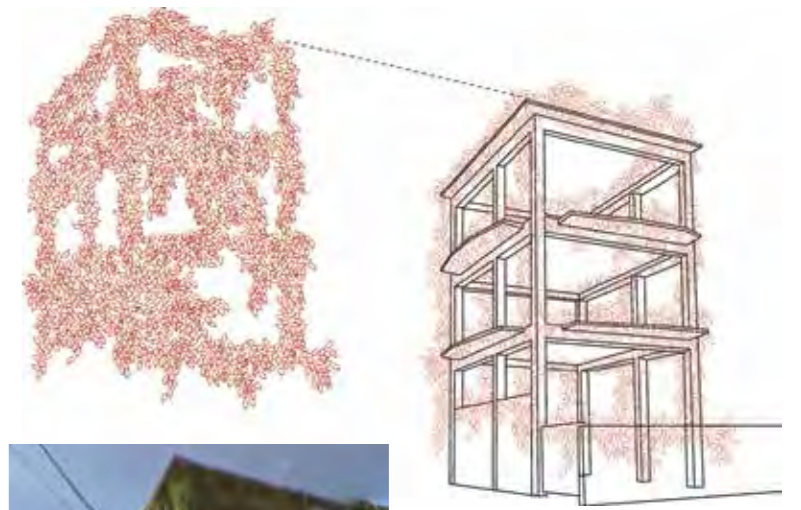

A *maifinito* covered by vegetation becomes an urban garden.



## Under the Canopies GELA, PROVINCE OF CALTANISSETTA

People of Gela, Sicily, using a roof canopy to obstruct their mayor's attempt to identify illegal construction via satellite.

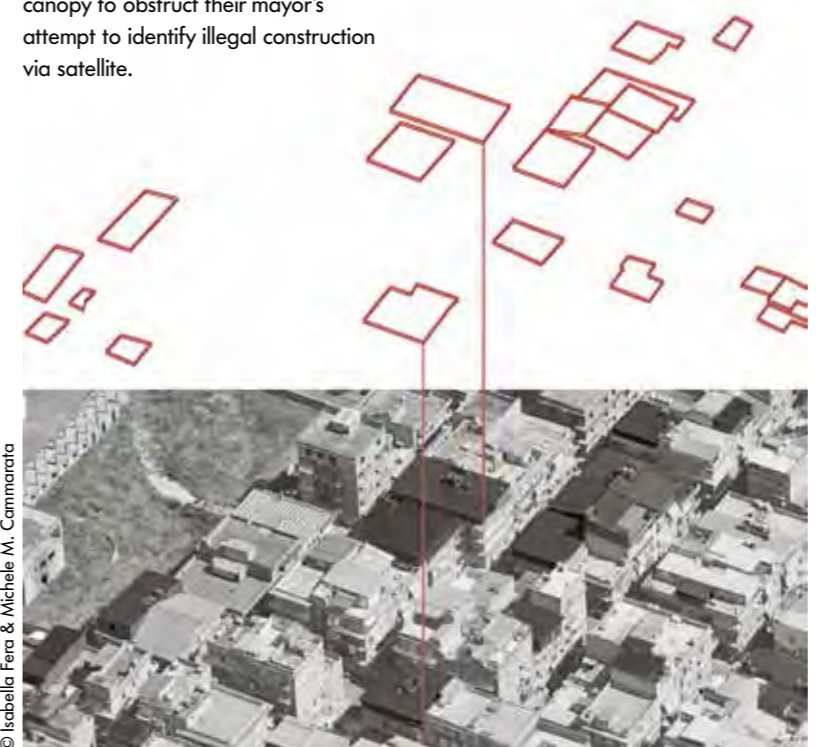

© Isabella Fera & Michele M. Cammarata

Prevalence of roof canopies in Gela, Sicily

The city of Gela, famous for the large number of illegal buildings constructed during its industrial heyday in the 1970s and 1980s, has also been at the forefront of the fight against illegal building practices in recent years. Across this large swathe of southern Sicily, illegal construction would begin on weekends or at night; and once a building began to look even marginally complete (sometimes only the barest building volume sufficed), it became impossible to stop. From that moment on, it was seen as a "violation" that had been committed, and therefore, in accordance with the regularization procedure, it was *remediable*. To put a stop to the practice, regulators had to intervene immediately, while construction was still underway—to catch violators in the act, so to speak. A factor that obviously served to aggravate the situation was the degree to which authorities tolerated the violations, as well as the total lack of effort they put into filing charges, resulting in the emergence of entire districts where nearly everyone had either committed, or was planning to commit, a violation of their own. Eventually, a system involving satellite photos and image-recognition software was introduced; at regular intervals, the software compared superimposed images of the buildings, automatically signalling any "aberrations" corresponding to an increase in volume or shape. Armed with

this evidence, authorities could initiate an inspection; if the work was unauthorized, it could be halted immediately. To get around the system, violators resorted to building a canopy over the flat roof of a building they planned to extend upwards. These canopies would be the same size and shape as the building below, so that when seen from above it didn't change at all—the light-weight structures were temporary in nature and usually made of sheetmetal and galvanized iron rods. Having successfully outwitted the system of control, you were then free to close in the space under the canopy as you desired, until you managed to complete an entire extra floor—precisely what the planning office would never have permitted and what the control system was designed to prevent. Although in many cases nothing was ever built beneath the canopies, the landscape today is nevertheless dotted with houses covered in lightweight canopies, which are useless for all intents and purposes, yet nonetheless lie there in wait, ready someday to be activated.<sup>4</sup>



# Legalizing Reality

## Bridge House RANDAZZO, PROVINCE OF CATANIA



This special instance of a *maifinito*, an incomplete viaduct left suspended over a river, has given rise to a very unusual transformation. The owners of the adjacent house decided to take possession of the bridge, in order “to stop cars falling off by mistake.” With considerable inventiveness and flair, they determined that their segment of the viaduct was not only strong enough to hold a vegetable garden—which they created by importing

new soil—but also strong enough to an extension of their own house. Adopting the attitude often seen in cases of unfinished buildings, namely opting not to submit detailed plans or apply for a building permit, they dealt with the inconvenience of an incomplete piece of infrastructure on their doorstep through this utilitarian and appropriative approach. By the same token, their action has served to rehabilitate an incomplete, useless, and forgotten piece of infrastructure, which otherwise would have fallen into ruin—even though, in actual point of fact, what they’ve occupied is a public road. And as if that weren’t enough, the owners decided to appropriate another small piece of land *under* the bridge, adding a small extension to the existing house, creating a structure adjacent to the lowest doorway with additional uses.<sup>5</sup>

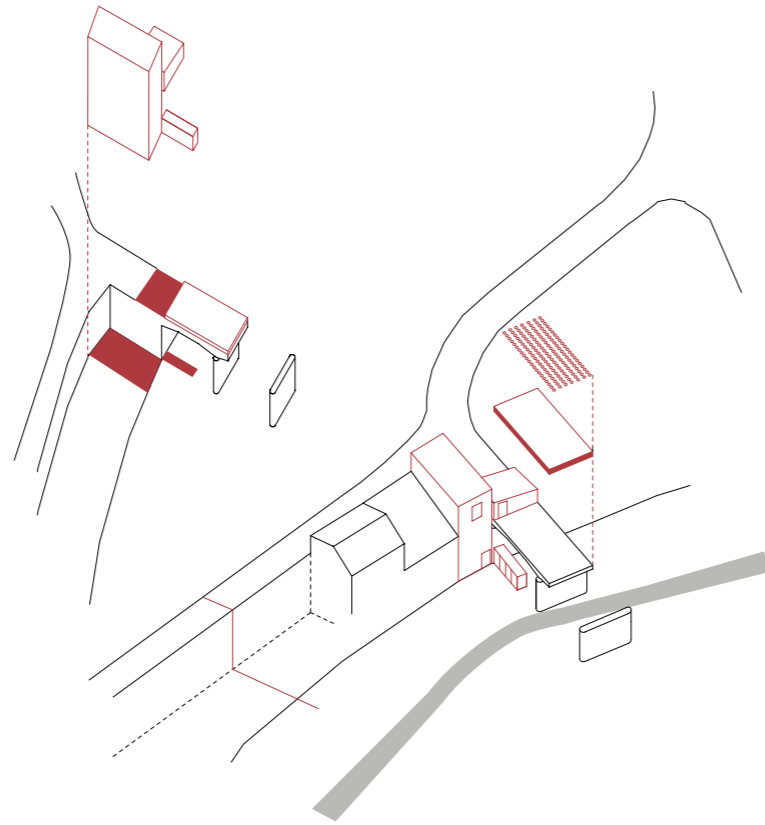

Axonometric view

© Isabella Fera & Michele M. Cammarata



© Luca Salmeri

An unfinished bridge has illegally been converted into a house with a hanging garden.



An empty concrete hillside structure was converted into a vertical farm.

## Vertical Farm ALTOFONTE, COMUNE OF PALERMO

In combination, the construction of a high-speed overhead highway (running between Palermo and Sciacca) near the town center and the area’s inaccessible topography have generated an extraordinary example of a hybrid building that combines elements of the town and country. Set behind a conventional three-story building located near the access road, another building towers out over five stories plus a basement, clinging to the ridge of Altofonte. The structure is a farm building: it shelters equipment on the ground floor, has space for animals on a lower terrace level, and features a warehouse and storage area in the basement. Yet the upper floors are taken up by apartments, some unfinished, in anticipation of the family’s grown-up members returning someday to live—something that never actually took place. A public road forks down from the access road leading to the town and passes below the building, so that, after the construction of new highway infrastructure and the hybrid apartment-building/farm, it now stands at the center of the original property. The property itself

stretches from beyond the access road to under and beyond the Palermo–Sciacca overpass. If we compare the structure to the neighboring buildings that can be seen from the ridge, we see a static arrangement of long “stilts,” supporting what appear to be normal buildings from the road. We can also see how the slope gradient has been put to good use, being gradually plugged in at intervals to produce living spaces and other structures. The building is currently in various stages of completion, ready to receive any alterations the future may have in store. For example, private access could be created for each of the different sub-units, serving to separate the public spaces and the surrounding private structures. One of the building’s strongest features might possibly be its exceptional position within the landscape stretching out before it, with its view across to the Conca d’Oro, Monte Pellegrino, the city of Palermo in the distance, and right down to the sea. All these elements stand ready to hand for designs that aim to complete or transform the site. This building, which may at first sight appear extremely poor and structurally complicated, is actually full of possibilities, idiosyncratic, and new potential.<sup>6</sup>

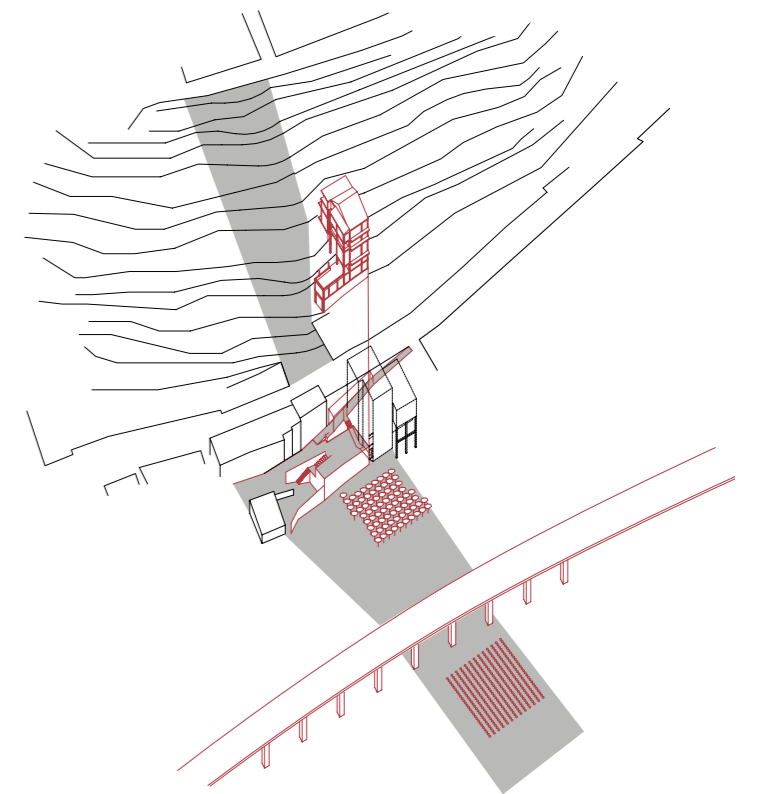

Axonometric view

1 Gaetano Licata, ed., *Maifinito* (Macerata: Quodlibet Studio, 2014), 48–51, 138.  
2 *Ibid.*, 54–55, 139.  
3 *Ibid.*, 44–45, 137.  
4 *Ibid.*, 52–53, 138–139.  
5 *Ibid.*, 46–47, 138.  
6 *Ibid.*, 42–43, 137.

© Isabella Fera & Michele M. Cammarata



# RELEASE ARCHITECTURE

# Legislating ARCHITECTURE

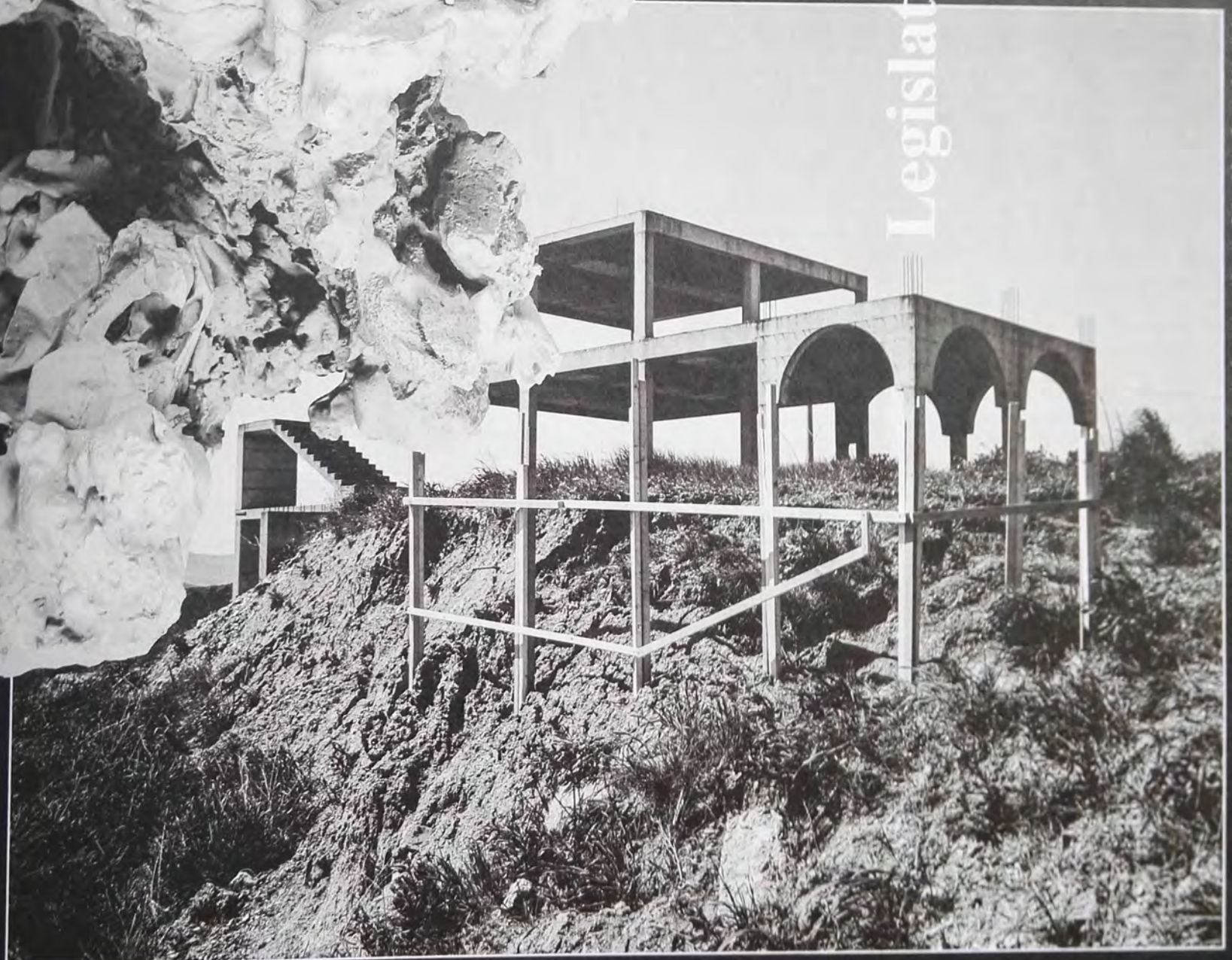

## ARCH+

For the 2016 Architecture Biennale, two issues of **ARCH+** take different perspectives on the autonomy and agency of architecture:

**LEGISLATING ARCHITECTURE**, a collaboration with Arno Brandhuber, investigates how law creates design, as well as the inverse: can design be applied to the pre-architectural realm? A report from architecture's legislative front.

**RELEASE ARCHITECTURE**, a collaboration with Christian Kerez, takes off from the spatial intervention in the Swiss Pavilion. How far can we push the boundaries of architectural space? A report from architecture's speculative front.

[www.archplus.net](http://www.archplus.net)





## ARCH+

Journal for Architecture  
and Urbanism

## PUBLISHER

ARCH+ Verlag GmbH, Sabine Kraft,  
Nikolaus Kuhnert, Günther Uhlig

## ARCH+ Verlag GmbH

Kurbrunnenstr. 22, D-52066 Aachen  
Internet: [www.archplus.net](http://www.archplus.net)  
eMail: [verlag@archplus.net](mailto:verlag@archplus.net)

## EDITORS

Nikolaus Kuhnert, Anh-Linh Ngo

## CO-EDITORS

Arno Brandlhuber, Tobias Höning

## ASSISTANT EDITORS

Sara Lusic-Alavanja, Rob Madole,  
Stephan Redeker, Achim Reese,  
Christine Rüb

## EDITORIAL ASSISTANTS

Tobias Gruber, Theresa Kraus

Grant recipients of the Sto Foundation  
and ARCH+ Association

Mirko Gatti, Katharina Kaufmann,  
Quang Tuan Ta

Grant recipients of  
the Hans Sauer Stiftung

Max Kaldenhoff

## ENGLISH-LANGUAGE EDITORS

Rob Madole, Sophie Duvernoy

## ENGLISH PROOFREADING

Cameron Cook,  
Vincent Meyer-Madaus

## GERMAN TO ENGLISH TRANSLATIONS

Büro LS Anderson (9-13, 66-69,  
92-99, 196-205), Justine Chaney  
(80-83, 184-185), Sophie Duvernoy  
(70-71, 114-117), Mathilde Lind  
Gustavussen (168-173, 222-223),  
Kat Hausler (72-75, 118-119, 158-163),  
May Koot (146-151), Steven Lindberg  
(100-111), Rob Madole (3-4, 155-157,  
186-191, 206, 207-208), Gillian  
Morris (88-91, 152-154, 174-181)

## INTERVIEW TRANSCRIPTIONS

Ursula Achternkamp, Tobias Höning,  
Theresa Kraus, Nicole Opel

## ARCH+ features Curator

Anh-Linh Ngo

## ART DIRECTION

Mike Meiré

## DESIGN

Charlotte Cassel, Tobias Tschense

## DISTRIBUTION, ADVERTISING, SINGLE ISSUE ORDERS

ARCH+ Verlag GmbH  
0049 (0) 241-50 83 03  
0049 (0) 241-548 31 (fax)  
[verlag@archplus.net](mailto:verlag@archplus.net)

## PRICE

€22

## ANNUAL SUBSCRIPTION FOR THE MAGAZINE (IN GERMAN)

In Germany €54, abroad €63  
(Advance payment required for  
international subscriptions)

Discount subscriptions available  
for students, recent graduates,  
and the unemployed:

In Germany €36, abroad €43

## COPYRIGHTS

Contents © 2016 ARCH+ Verlag  
GmbH, and the authors, translators,  
and artists. All rights to the publication  
reserved by ARCH+ Verlag GmbH,  
and rights to the works contained  
herein reserved by their owners. No  
part of this publication may be  
reproduced without proper citation  
and the permission of the publisher.

ARCH+ assumes no responsibility  
for unsolicited submissions.

## IMAGE CREDITS

ARCH+ has made every effort  
to notify all copyright holders. Any  
persons or institutions wishing to  
make a copyright claim are requested  
to contact the editors.

## PRINTING

optimal media GmbH, Röbel

## PREPRESS

max-color, Berlin

ISBN: 978-3-931435-34-9

## ACKNOWLEDGEMENTS

ARCH+ extends its sincere gratitude  
to Arno Brandlhuber, Tobias Höning,  
and their team for collaborating on  
this publication. We also thank all the  
authors who responded to our open  
call. Our heartfelt gratitude also  
goes out to Peter Strobel of Siedle for  
supporting the English translations,  
as well as to Fredi Fischli and Niels  
Olsen for organizing the preview of the  
publication in the exhibition Legislating  
Architecture Schweiz at GTA/ETH  
Zurich. We would also like to thank  
Armen Avanesian, Christian Kerez,  
Sandra Oehy, Erica Overmeer,  
Christopher Roth, and Stephan Trüby,  
whose support was crucial in the  
making of this publication. Finally, we  
especially thank Alejandro Aravena,  
curator of La Biennale di Venezia 2016,  
for inviting Brandlhuber+ and  
Christopher Roth to take part at the  
presentation in the Central Pavilion  
in the Giardini.

## COLLABORATIONS

We would like to thank the  
Sto Foundation, the Hans Sauer  
Stiftung, and the ARCH+ Association  
for their collaboration in the grants  
program for the advancement  
of discourse in architecture and  
urbanism.

Sto  Stiftung

 Hans Sauer  
Stiftung

ARCH+  
FOERDERVEREIN

[www.sto-stiftung.de](http://www.sto-stiftung.de)  
[www.hanssauerstiftung.de](http://www.hanssauerstiftung.de)  
[www.archplusverein.de](http://www.archplusverein.de)

ARCH+ features is made possible  
through the generous support of  
Siedle (initiative partner), Dornbracht,  
and Euroboden.

SSS SIEDLE

DORN  
BRACHT

EUROBODEN

ARCHITEXTURKULTUR



© Christopher Roth