



Neotropical primate evolution and phylogenetic reconstruction using chromosomal data

F. Dumas & S. Mazzoleni

To cite this article: F. Dumas & S. Mazzoleni (2017) Neotropical primate evolution and phylogenetic reconstruction using chromosomal data, The European Zoological Journal, 84:1, 1-18, DOI: [10.1080/11250003.2016.1260655](https://doi.org/10.1080/11250003.2016.1260655)

To link to this article: <http://dx.doi.org/10.1080/11250003.2016.1260655>



© 2017 The Author(s). Published by Informa UK Limited, trading as Taylor & Francis Group.



Published online: 18 Jan 2017.



Submit your article to this journal [↗](#)



View related articles [↗](#)



View Crossmark data [↗](#)

Neotropical primate evolution and phylogenetic reconstruction using chromosomal data

F. DUMAS^{1*} & S. MAZZOLENI^{1,2}

¹Department of “Scienze e Tecnologie Biologiche, Chimiche e Farmaceutiche”, University of Palermo, Italy, and ²Department of Ecology, Faculty of Science, Charles University, Prague, Czech Republic

(Received 11 March 2016; accepted 3 November 2016)

Abstract

Platyrrhini are a group of Neotropical primates living in central and south America, and have been extensively studied through morphological and molecular data in order to shed light on their phylogeny and evolution. Agreement on the main clades of Neotropical primates has been reached using different approaches, but many phylogenetic nodes remain under discussion. Contrasting hypotheses have been proposed, presumably due to different markers and the presence of polymorphisms in the features considered; furthermore, neither Neotropical primate biodiversity nor their taxonomy are entirely known. In our perspective, a cytogenetic approach can help by making an important contribution to the evaluation of the phylogenetic relationships among Platyrrhini. In this work, molecular cytogenetic data regarding the principal nodes of the Neotropical monkey tree have been reviewed; classical cytogenetic data have also been considered, especially when other data have proven elusive, permitting us to discuss highly derived karyotypes characterized by a wide range of diploid numbers of chromosomes and variable chromosomal evolution with different rearrangement and polymorphism rates.

Keywords: Neotropical monkeys, molecular cytogenetics, painting, human associations, genome

Introduction

Platyrrhini are small anthropoids of the superfamily Ceboidea, grouped into three families and many genera with about 120 living species, which inhabit the trees of tropical forests, ranging from Central to South America.

Molecular analysis has revealed a unique phylogenetic arrangement of Platyrrhini, with three monophyletic families: Cebidae, Atelidae and Pitheciidae (Schneider et al. 1993, 1996, 2001; Von Dornum & Ruvolo 1999; Ray et al. 2005; Opazo et al. 2006; Osterholz et al. 2009; Wildman et al. 2009; Perelman et al. 2011; Kiesling et al. 2015); however, the relationships among the three major clades remain under discussion. Indeed, molecular data have permitted researchers to hypothesize Cebidae as a sister clade of Atelidae and Pitheciidae (Figure 1(a); Schneider et al.

1996, 2001; Canavez et al. 1999b; Opazo et al. 2006) or, alternatively, Pitheciidae as a sister clade of the two remaining families (Figure 1(b); Ray et al. 2005; Osterholz et al. 2009; Wildman et al. 2009; Perelman et al. 2011; Kiesling et al. 2015).

In the following discussions of each family (Cebidae, Atelidae and Pitheciidae), their principal features as well as phylogenetic relationships, according to recent molecular data, are reported. Indeed, Platyrrhini have also been studied in depth at the intra-family level, analyzing intergenus and intragenus relationships. The principal works on Platyrrhini phylogeny, using different molecular markers for their analyses, at various levels are reported below (Table I). The Cebidae family includes many genera and is marked by a close relationship between *Cebus* (capuchin

*Correspondence: F. Dumas, Department of “Scienze e Tecnologie Biologiche, Chimiche e Farmaceutiche”, University of Palermo, Palermo 90133, Italy. Tel: +39 09123891822. Email: francesca.dumas@unipa.it

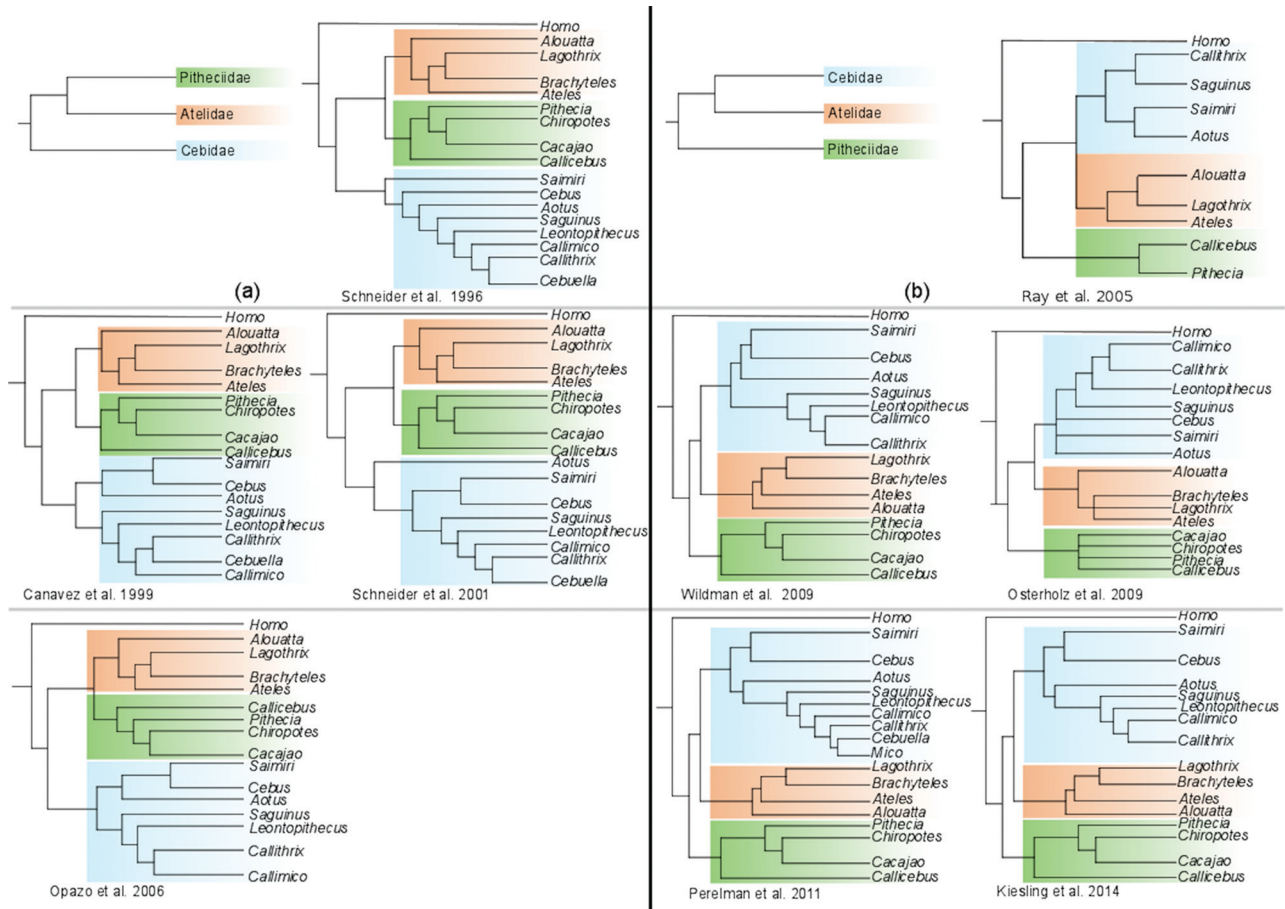

Figure 1. Phylogenetic trees reconstructed on the basis of different molecular markers: (a) with Cebidae as sister group to the Atelidae and Pitheciidae clade (Schneider et al. 1996, 2001; Canavez et al. 1999a; Opazo et al. 2006); (b) with Pitheciidae as sister clade to that of Atelidae and Cebidae (Ray et al. 2005; Osterholz et al. 2009; Wildman et al. 2009; Perelman et al. 2011; Kiesling et al. 2015).

monkeys) and *Saimiri* (squirrel monkeys) (Schneider et al. 2001; Perelman et al. 2011) which share many characteristics at the morphological level that indicate a common origin, such as a high ratio of brain/body weight, pronounced sexual dimorphism, and the ability to gradually change their diet which is based mainly on fruits and insects. However, they also have some differences; for example, capuchin monkeys (*Cebus* and *Sapajus*) have a semi-prehensile tail which is unable to sustain weight, whereas *Saimiri* are born with prehensile tails but lose grasping ability as they age.

Among Cebidae it is also possible to distinguish *Callithrix* (Atlantic marmosets), *Cebuella* (marmosets), *Saguinus* (tamarins), and *Leontopithecus* (lion tamarins); the latter, also known as callitrichids, are characterized, with some exceptions, by small body size, claw-like nails on all digits but the

hallux, two molars instead of three, and dietary exploitation of plant exudates (gums and saps). In addition, there is a peculiarity in marmosets in that they are known to give birth to twins. Another Cebidae genus is the monotypic *Callimico* (Goeldi's monkeys), with the species *C. goeldii* characterized by small body size and claw-like nails like marmosets, as well as by other features more typical of larger bodied Platyrrhini, such as a third molar and single births. For this reason, its phylogenetic position has been highly debated, although it is now considered to be resolved (Canavez et al. 1999b; Schneider et al. 2001). Among callitrichids, indeed, molecular phylogenetic reconstructions present *Saguinus* as the sister taxa of *Leontopithecus* and *Callimico* as well as the *Callithrix* and *Cebuella* clades (Schneider et al. 2001; Perelman et al. 2011).

Table I. List of platyrrhine phylogenetic studies based on molecular markers and references; letters C, A and P stand for Cebidae, Atelidae and Pitheciidae, respectively; (*) see article for species identification.

Markers	Species analyzed	References
LINE-1 patterns	C: <i>Callimico goeldii</i> , <i>Callithrix jacchus</i> , <i>Cebuella pygmaea</i> , <i>Leontopithecus rosalia</i> , <i>Saguinus labiatus</i> , <i>Sapajus apella</i> A: <i>Ateles fusciceps</i> P: <i>Callicebus moloch</i>	Seuánez et al. (1988)
Molecular sequences combined in tandem, ε globin and IRBP	C: <i>Aotus azarae</i> , <i>Callimico goeldii</i> , <i>Callithrix jacchus</i> , <i>Cebuella pygmaea</i> , <i>Leontopithecus rosalia</i> , <i>Saguinus midas</i> , <i>Saimiri sciureus</i> A: <i>Alouatta belzebul</i> , <i>A. seniculus</i> , <i>Ateles belzebuth</i> , <i>A. geoffroyi</i> , <i>Brachyteles arachnoides</i> , <i>Lagothrix lagotricha</i> P: <i>Cacajao calvus</i> , <i>C. moloch</i> , <i>Callicebus torquatus</i> , <i>Chiropotes satanas</i> , <i>Pithecia irrorata</i> C: <i>Aotus azarae</i> , <i>A. nancymaii</i> , <i>Callimico goeldii</i> , <i>Callithrix jacchus</i> , <i>Cebuella pygmaea</i> , <i>Cebus kaapori</i> , <i>Cebus nigrivittatus</i> , <i>Leontopithecus rosalia</i> , <i>Saguinus bicolor</i> , <i>S. midas</i> , <i>Saimiri boliviensis</i> , <i>S. sciureus</i> A: <i>Alouatta belzebul</i> , <i>Ateles belzebuth</i> , <i>Brachyteles arachnoides</i> , <i>Lagothrix lagotricha</i> P: <i>Cacajao calvus</i> , <i>Callicebus moloch</i> , <i>C. torquatus</i> , <i>Chiropotes satanas</i> , <i>Pithecia irrorata</i>	Schneider et al. (1993) Schneider et al. (1996); Schneider et al. (2001) (*)
Analysis of cytochrome b	C: <i>Callithrix jacchus jacchus</i> , <i>Leontopithecus rosalia chrysomelas</i> , <i>L. rosalia chrysopygus</i> , <i>L. rosalia rosalia</i> , <i>Saguinus oedipus</i> , <i>Sapajus apella</i> A: - P: -	Moreira et al. (1996)
ε globin and IRBP	C: <i>Callimico goeldii</i> , <i>Callithrix jacchus</i> , <i>Cebuella pygmaea</i> , <i>Leontopithecus chrysomelas</i> , <i>L. chrysopygus</i> , <i>L. rosalia</i> , <i>Mico emiliae</i> , <i>Saguinus oedipus</i> , <i>Sapajus apella</i> A: - P: -	Moreira and Seuánez (1999)
	C: <i>Callithrix geoffroyi</i> , <i>C. jacchus</i> , <i>C. mauesi</i> , <i>Cebuella pygmaea</i> , <i>Mico argentatus</i> A: - P: -	Porter et al. (1997)
DNA sequences of mitochondrial genes	C: <i>Callithrix argentata</i> , <i>C. aurita</i> , <i>C. geoffroyi</i> , <i>C. humeralifer</i> , <i>C. jacchus</i> , <i>C. kuhlii</i> , <i>C. mauesi</i> , <i>C. penicillata</i> , <i>Cebuella pygmaea</i> , <i>Leontopithecus chrysomelas</i> A: - P: -	Tagliaro et al. (1997)
Mitochondrial DNA	C: <i>Callimico goeldii</i> , <i>Callithrix jacchus</i> , <i>Cebuella pygmaea</i> , <i>Leontopithecus chrysomelas</i> , <i>L. rosalia</i> , <i>Saguinus midas</i> , <i>Sapajus apella</i> A: <i>Ateles geoffroyi</i> P: - C: <i>Cebus capucinus</i> A: <i>Alouatta belzebul belzebul</i> , <i>A. caraya</i> , <i>A. coibensis coibensis</i> , <i>A. coibensis trabeata</i> , <i>A. guariba</i> , <i>A. macconelli</i> , <i>A. palliata aequatorialis</i> , <i>A. palliata mexicana</i> , <i>A. palliata palliata</i> , <i>A. pigra</i> , <i>A. sara</i> , <i>A. seniculus seniculus</i> , <i>A. seniculus Ateles geoffroyi vellerosus</i> , <i>A. geoffroyi yucatanensis</i> , <i>A. fusciceps robustus</i> , <i>Brachyteles arachnoides</i> P: -	Pastorini et al. (1998) Cortés-Ortiz et al. (2003)
Genes 12S + 16S	C: <i>Aotus trivirgatus</i> , <i>Callimico goeldii</i> , <i>Callithrix jacchus</i> , <i>Cebuella pygmaea</i> , <i>Leontopithecus rosalia</i> , <i>Saguinus geoffroyi</i> , <i>S. oedipus</i> , <i>Saimiri sciureus</i> , <i>Sapajus apella</i> A: <i>Alouatta palliata</i> , <i>A. seniculus</i> , <i>Ateles sp.</i> , <i>Brachyteles arachnoides</i> , <i>Lagothrix lagotricha</i> P: <i>Callicebus moloch</i> , <i>Chiropotes satanas</i> , <i>Pithecia pithecia</i>	Horovitz et al. (1998)
Nuclear sequences	C: <i>Aotus azarae</i> , <i>Callimico goeldii</i> , <i>Callithrix humeralifera</i> , <i>C. kuhlii</i> , <i>C. penicillata</i> , <i>Cebuella pygmaea</i> , <i>Cebus olivaceus</i> , <i>Leontopithecus chrysopygus</i> , <i>Mico emiliae</i> , <i>Saguinus midas</i> , <i>Saimiri boliviensis</i> , <i>S. sciureus</i> , <i>S. ustus</i> A: <i>Alouatta seniculus</i> , <i>Ateles paniscus</i> , <i>Brachyteles arachnoides</i> , <i>Lagothrix lagotricha</i> P: <i>Cacajao melanocephalus</i> , <i>Callicebus hoffmannsi</i> , <i>C. moloch</i> , <i>C. personatus nigrifrons</i> , <i>C. personatus personatus</i> , <i>C. torquatus</i> , <i>Chiropotes satanas</i>	Canavez et al. (1999b)

(Continued)

Table I. (Continued).

Markers	Species analyzed	References
	C: <i>L. chrysomelas</i> , <i>L. chrysopygus</i> , <i>Leontopithecus rosalia</i> A: - P: -	Mundy and Kelly (2001)
	C: <i>Aotus</i> , <i>Callithrix</i> , <i>Callimico</i> , <i>Cebus</i> , <i>Leontopithecus</i> , <i>Saguinus</i> , <i>Saimiri</i> A: <i>Alouatta</i> , <i>Ateles</i> , <i>Brachyteles</i> , <i>Lagothrix</i> P: <i>Cacajao</i> , <i>Callicebus</i> , <i>Chiropotes</i> , <i>Pithecia</i>	Opazo et al. (2006) (*)
Genetic loci	C: - A: <i>Ateles paniscus chamek</i> P: -	Seuáñez et al. (2001)
SRY (The region of the Y chromosome in sex determination)	C: <i>Aotus azarae</i> , <i>A. infulatus</i> , <i>A. lemurinus griseimembra</i> , <i>Callimico goeldii</i> , <i>Callithrix aurita</i> , <i>C. geoffroyi</i> , <i>C. jacchus</i> , <i>C. kuhlii</i> , <i>C. penicillata</i> , <i>Cebuella pygmaea</i> , <i>Cebus albifrons</i> , <i>C. capucinus</i> , <i>C. nigrivittatus</i> , <i>Leontopithecus chrysomelas</i> , <i>L. chrysopygus</i> , <i>L. rosalia</i> , <i>Saguinus midas midas</i> , <i>Sapajus apella apella</i> , <i>S. a. xanthosternus</i> A: - P: -	Moreira (2002)
Alu elements	C: <i>Aotus azarae</i> , <i>Callimico goeldii</i> , <i>Callithrix jacchus</i> , <i>C. geoffroyi</i> , <i>C. penicillata</i> , <i>Cebuella pygmaea</i> , <i>Leontopithecus chrysomelas</i> , <i>L. chrysopygus</i> , <i>L. rosalia</i> , <i>Saguinus bicolor</i> , <i>S. fuscicollis</i> , <i>S.f. lagonotus</i> , <i>S. labiatus</i> , <i>S. midas</i> , <i>S. oedipus</i> , <i>Saimiri sciureus</i> , <i>Sapajus apella</i> A: <i>Alouatta belzebul</i> , <i>Ateles fusciceps</i> , <i>Lagothrix lagotricha</i> P: <i>Cacajao calvus</i> , <i>Callicebus cupreus</i> , <i>Chiropotes satanas albinasus</i> , <i>Pithecia pithecia</i>	Singer et al. (2003)
	C: <i>Aotus trivirgatus</i> , <i>Callithrix pygmaea</i> , <i>Saguinus labiatus</i> , <i>Saimiri sciureus</i> A: <i>Alouatta sara</i> , <i>Ateles geoffroyi</i> , <i>Lagothrix lagotricha</i> P: <i>Callicebus d. donacophilus</i> , <i>Pithecia p. pithecia</i>	Ray et al. (2005)
Sequences from two non-coding regions of nuclear genes	C: <i>Saimiri sciureus</i> / <i>Cebus</i> A: <i>Alouatta belzebul</i> , <i>Ateles geoffroyi</i> , <i>Atelesp.</i> , <i>Brachyteles arachnoides</i> , <i>Lagothrix lagotricha</i> P: -	Lima et al. (2007)
SINE	C: <i>Aotus azarae</i> , <i>Callimico goeldii</i> , <i>Cebuella pygmaea</i> , <i>Leontopithecus chrysomelas</i> , <i>Saguinus imperator</i> , <i>Saimiri sciureus</i> , <i>Sapajus apella</i> A: <i>Alouatta caraya</i> , <i>Ateles fusciceps</i> , <i>Lagothrix lagotricha</i> P: <i>Cacajao calvus</i> , <i>Chiropotes albinasus satanas</i> , <i>Pithecia pithecia</i>	Osterholz et al. (2009)
Nuclear DNA markers derived from a random genomic shotgun library	C: <i>Aotus lemurinus</i> , <i>A. azarae</i> , <i>Callimico goeldii</i> , <i>Callithrix penicillata</i> , <i>Leontopithecus chrysomelas</i> , <i>Saguinus midas</i> , <i>Saimiri sciureus</i> , <i>Sapajus apella</i> A: <i>Alouatta caraya</i> , <i>Ateles belzebuth</i> , <i>Brachyteles arachnoides</i> , <i>Lagothrix lagotricha</i> P: <i>Cacajao calvus</i> , <i>Callicebus personatus</i> , <i>C. torquatus</i> , <i>Chiropotes satanas</i> , <i>Pithecia irrorata</i>	Wildman et al. (2009)
Large-scale concatenated data set of multiple nuclear/mitochondrial regions	C: <i>Aotus azarae boliviensis</i> , <i>A. azarae infulatus</i> , <i>A. azarae</i> , <i>A. nancymae</i> , <i>A. lemurinus griseimembra</i> , <i>A. trivirgatus</i> , <i>Callimico goeldii</i> , <i>Callithrix jacchus</i> , <i>C. penicillata</i> , <i>C. geoffroyi</i> , <i>C. kuhlii</i> , <i>C. aurita</i> , <i>Cebuella pygmaea</i> , <i>Cebus robustus</i> , <i>C. xanthosternus</i> , <i>C. capucinus</i> , <i>C. albifrons</i> , <i>C. olivaceus</i> , <i>Leontopithecus chrysomelas</i> , <i>L.rosalia</i> , <i>Mico argentata</i> , <i>M. humeralifer</i> , <i>Saguinus bicolor</i> , <i>S. martinsi</i> , <i>S. midas</i> , <i>S. geoffroyi</i> , <i>S. oedipus</i> , <i>S. labiatus</i> , <i>S. imperator</i> , <i>S. fuscicollis</i> , <i>Saimiri boliviensis boliviensis</i> , <i>S. oestedii oestedii</i> , <i>S. sciureus</i> , <i>S. ustus</i> , <i>Sapajus apella</i> A: <i>Alouatta belzebul</i> , <i>A. caraya</i> , <i>A. sara</i> , <i>A. palliata</i> , <i>Ateles belzebuth</i> , <i>A. geoffroyi</i> , <i>A. hybridus</i> , <i>A. fusciceps</i> , <i>A. chamek</i> , <i>A. paniscus</i> , <i>Brachyteles arachnoides</i> , <i>B. hypozantus</i> , <i>Lagothrix cana</i> , <i>L. lagotricha</i> P: <i>Cacajao melanocephalus</i> , <i>C. calvus</i> , <i>Callicebus brunneus</i> , <i>C. moloch</i> , <i>C. cupreus</i> , <i>C. caligatus</i> , <i>C. donacophilus</i> , <i>C. coimbrai</i> , <i>C. personatus</i> , <i>C. nigrifrons</i> , <i>Chiropotes israelita</i> , <i>C. satanas chiropotes</i> , <i>Pithecia irrorata</i> , <i>P. pithecia</i>	Perelman et al. (2011)

(Continued)

Table I. (Continued).

Markers	Species analyzed	References
	C: <i>Callimico goeldii</i> , <i>Callithrix aurita</i> , <i>C. geoffroyi</i> , <i>C. jacchus</i> , <i>C. kuhlii</i> , <i>C. penicillata</i> , <i>Cebuella pygmaea</i> , <i>Leontopithecus chrysomelas</i> , <i>Mico argentatus</i> , <i>M. humeralifer</i> , <i>M. mauesi</i> , <i>M. humilis</i> , <i>M. saterei</i>	Schneider et al. (2012)
	A: -	
	P: -	
	C: <i>Callimico goeldii</i> , <i>Callithrix aurita</i> , <i>C. geoffroyi</i> , <i>C. kuhlii</i> , <i>C. jacchus</i> , <i>C. penicillata</i> , <i>Cebuella pygmaea</i> , <i>Leontopithecus caissara</i> , <i>L. chrysomelas</i> , <i>L. chrysopygus</i> , <i>L. rosalia</i> , <i>Mico argentatus</i> , <i>M. emiliae</i> , <i>M. humeralifer</i> , <i>M. mauesi</i> , <i>M. saterei</i> , <i>Saguinus nigricollis nigricollis</i> , <i>S. nigricollis graellsii</i> , <i>S. fuscicollis illigeri</i> , <i>S. tripartitus</i> , <i>S. fuscicollis lagonotus</i> , <i>S. weddelli weddelli</i> , <i>S. weddelli melanoleucus</i> , <i>S. fuscicollis nigrifrons</i> , <i>S. fuscicollis leucogenys</i> , <i>S. fuscicollis fuscicollis</i> , <i>S. imperator</i> , <i>S. labiatus</i> , <i>S. inustus</i> , <i>S. mystax</i> , <i>S. leucopus</i> , <i>S. oedipus</i> , <i>S. geoffroyi</i> , <i>S. niger</i> , <i>S. midas</i> , <i>S. bicolor</i> , <i>S. martinsi</i>	Buckner et al. (2014)
	A: -	
	P: -	
	C: <i>Aotus azarae</i> , <i>A. lemurinus</i> , <i>A. nancymaeae</i> , <i>Callithrix flaviceps</i> , <i>C. geoffroyi</i> , <i>C. jacchus</i> , <i>C. kuhlii</i> , <i>C. penicillata</i> , <i>Callimico goeldii</i> , <i>Cebus albifrons</i> , <i>C. nigritus</i> , <i>C. olivaceus</i> , <i>C. xanthosternos</i> , <i>Leontopithecus chrysomelas</i> , <i>Mico argentatus</i> , <i>Saguinus fuscicollis</i> , <i>S. imperator</i> , <i>S. martinsi</i> , <i>S. niger</i> , <i>Saimiri sciureus</i> , <i>S. ustus</i> , <i>Sapajus apella</i>	Kiesling et al. (2015)
	A: <i>Alouatta belzebul</i> , <i>A. palliata</i> , <i>Ateles belzebuth</i> , <i>A. geoffroyi</i> , <i>A. paniscus</i> , <i>Brachyteles arachnoides</i> , <i>Lagothrix lagotricha</i>	
	P: <i>Cacajao calvus</i> , <i>Callicebus donacophilus</i> , <i>C. nigrifrons</i> , <i>Chiropotes utahicki</i> , <i>Pithecia irrorata</i>	

Moreover, Cebidae includes the genus *Aotus* (owl/night monkeys), the only representative platyrrhine species having nocturnal habits, characterized by monogamous social organization in small groups. *Aotus* is primarily frugivorous, but these primates also consume leaves and insects. The phylogenetic position of *Aotus* has been highly debated and still remains unclear; it is supposed to be a sister clade to either *Cebus/Saimiri* (Opazo et al. 2006; Wildman et al. 2009) or callitrichines (Perelman et al. 2011; Kiesling et al. 2015). Moreover, other research has led to conflicting phylogenetic reconstructions on the basis of the markers analyzed (Perez et al. 2012).

Three additional Cebidae genera have also been proposed and supported by molecular-level factors: *Mico* (from *Callithrix*) (Lynch Alfaro et al. 2012a,b), *Leontocebus* (from *Saguinus*), (Buckner et al. 2014; Sampaio et al. 2015) and *Sapajus* (from *Cebus*) (Schneider et al. 2012; Schneider & Sampaio 2015).

Atelidae includes four genera: *Alouatta* (howler monkeys), its sister clade *Ateles* (spider monkeys), and the *Brachyteles* (muriquis)/*Lagothrix* (woolly monkeys) clade (Schneider et al. 1996; Lima et al. 2007). These monkeys are characterized by

large body size, frugivorous–folivorous diet, and a muscular prehensile tail used to support their weight.

Pitheciidae includes four genera: the highly specialized seed predators *Pithecia* (saki monkeys), *Chiropotes* (bearded sakis), and *Cacajao* (uakaris) which have the *Callicebus* genus (titi monkeys) as their sister taxon (Canavez et al. 1999b; Schneider et al. 2001; Opazo et al. 2006; Wildman et al. 2009; Perelman et al. 2011).

Comparative cytogenetics and phylogenetic reconstructions

Classic cytogenetic studies using banding analysis allowed researchers to demonstrate that primate chromosomes have been conserved during evolution (Dutrillaux 1979, 1988; Dutrillaux & Couturier 1981; Dutrillaux et al. 1986). Since the 1990s (Wienberg et al. 1990), the karyotypes of different primate species have also been compared at the molecular level, applying fluorescent *in situ* hybridization (FISH) with human chromosomal probes. This molecular cytogenetic approach is known as “chromosome painting” and consists of the hybridization of the human

DNA probes of a whole chromosome (labeled with a fluorescent substance) with the DNA of a target species, taking advantage of their complementary nature. Chromosome painting allows researchers to determine chromosomal homologies at the level of whole or partial chromosomes, as well as interchromosomal rearrangements (translocations, fissions and fusions) that have occurred during evolution; chromosomal painting permits the determination of which chromosomes, or chromosomal synteny (the localization of two or more genes on the same chromosome), have been conserved or reshaped, identifying syntenic associations in the genomes of the species being compared.

Subsequently, it has been possible to hybridize not only human probes but even other animal probes (zoo-FISH) made through flow sorting. Human and other primate probes have been reciprocally hybridized through chromosome painting, permitting the detection of real homologies in two reciprocal experiments and rearrangement breakpoints (Stanyon et al. 2001; Dumas et al. 2007). In recent years, sub-regional or locus-specific probes, produced by microdissection or by cloning DNA within vectors, have also been used for FISH. These probes have demonstrated a high resolving power, identifying intrachromosomal rearrangements and breakpoints that are not detectable through painting (Stanyon et al. 2008).

Chromosomal data obtained through comparative cytogenetics have been used for phylogenetic reconstructions using the cladistic approach and the principle of parsimony. The first step in this field is making the distinction between homology due to shared ancestry and homoplasy due to parallel or convergent evolution; thus, among homologies, it is necessary to distinguish ancestral chromosomal synteny (synapomorphies) from new shared syntenic associations (symplesiomorphies) formed as a consequence of chromosomal rearrangements (Wienberg & Stanyon 1995; Rokas & Holland 2000). Since rearrangements are rare events in mammals (two for every 10 million years, Froenicke 2005; Murphy et al. 2005), the common derivative syntenic associations between two species are useful for phylogenetic reconstructions. Through this analysis, in a comparative perspective, it has been possible to reconstruct the hypothetical ancestral karyotype of all primates and of the main nodes of the primate evolutionary tree (Stanyon et al. 2008). To distinguish conserved from derived characteristics, a

comparison with an outgroup – a closely related species that is considered external to the group under examination – is used. According to the principle of parsimony, the interpretation that involves the least likely number of steps is preferred among the various possible interpretations of a phenomenon (chromosomal organization). Another aspect to take into account in phylogenetic reconstructions, and which complicates the analysis, is the distinction of hemiplasy due to the phylogenetic sorting of a genetic polymorphism (Avice & Robinson 2008; Robinson et al. 2008).

Ancestral platyrrhini karyotype

The pioneering studies on the chromosomes of Neotropical primates through classical cytogenetic analysis started in the 1970s (Dutrillaux 1979, 1988; Dutrillaux & Couturier 1981; Dutrillaux et al. 1986), while the molecular cytogenetic approach was first applied in the 1990s to *Callithrix jacchus* (Sherlock et al. 1996), *Cebus capucinus* (Richard et al. 1996), *Alouatta seniculus arctoides*, *A. sara* (Consigliere et al. 1996) and *Ateles paniscus chamek* (Canavez et al. 1998, 1999a). These works allowed scientists to verify the chromosomal homologies proposed in the literature, based on comparative banding analysis (Stanyon et al. 1995). Furthermore, chromosomal painting studies applied to many primates permitted researchers to reconstruct the putative ancestral karyotype of New World monkeys characterized by diploid number $2n = 54$, with the following synteny or human syntenic associations: 1a, 1b, 1c, 2a, 2b/16b, 3a, 3b, 3a/21, 4, 5/7a, 6, 7b, 8b, 8a/18, 9, 10p 10a/16a, 11, 12, 13, 14/15a, 15b, 17, 19, 20, 22, X and Y (Neusser et al. 2001; Stanyon et al. 2008). This karyotype derives from the hypothetical one of all primates ($2n = 50$, with chromosomes 1, 2a, 2b, 3/21, 4, 5, 6, 7a, 7b/16b, 8, 9, 10a, 10b, 11, 12a/22a, 12b/22b, 13, 14/15, 16a, 17, 18, 19a, 19b, 20, X and Y) via six fissions in four chromosomes (1, 3/21, 8 and 14/15) and by four fusions which form syntenic associations (2b/16b, 5/7a, 8a/18 and 10a/16a). Some ancestral primate associations are not present in New World monkeys due to previous rearrangements which occurred in the anthropoid branch – in particular, a fission of 7b/16b, a reciprocal translocation producing chromosome 12, and a fusion giving the whole chromosome 19.

Discussion

The aim of this work is to review the molecular cytogenetic data available in the literature for any major lineages of the platyrrhine tree (Table II) while also considering useful classical cytogenetic data. We report human associations and evolutionary rearrangements characterizing the principal nodes of the Neotropical primate tree. The tree adopted is the one proposed by Perelman et al. (2011), in terms of the families recognized, but with some modifications made in order to take into account chromosomal data at the inter- and intragenetic levels. Furthermore, we also point out principal cytogenetic data that are in conflict with molecular data. In particular, the New World monkey data gathered are discussed below, for each family (Cebidae, Atelidae and Pitheciidae) and for each genus within it, following the tree reported in Figure 2(a–c). This phylogenetic tree was drawn using Mesquite, a software program for evolutionary biology designed to help biologists organize and analyze comparative data. A previous review of the same topic (De Oliveira et al. 2012) has been published, explaining conflicting features through traditional interpretative hypotheses, taking into account the distinction between homologies and homoplasy. In addition to this, we explain the possible evolutionary scenarios, considering hemiplasy in addition to homology and homoplasy. Some discordance in evolutionary interpretation can occur when a tree constructed through chromosomal data is not in accordance with a species tree due to the phylogenetic sorting of a genetic polymorphism; this kind of evolutionary event is termed hemiplasy.

Cebidae family

Cytogenetic analysis of the data found in the literature shows low variability within and between species, in both the number and structure of chromosomes in the Cebidae family (Dutrillaux & Couturier 1981; Seuánez et al. 1988; Nagamachi et al. 1997a,b, 1999), showing highly conservative genomes with diploid numbers of chromosomes ranging between 44 and 54. This has led researchers to assume that the adaptive radiation of Cebidae was characterized by a limited number of chromosomal rearrangements.

Chromosomal painting data enabled us to show that all of the synteny in the putative ancestral platyrrhine karyotype (i.e., 3a/21, 5/7a, 2b/16b, 8a/18, 14/15a, and 10a/16a) were conserved in *Cebus*, and *Mico*. *C. capucinus*, *C. albifrons* and even *Sapajus*

apella, previously known as *C. apella* (Richard et al. 1996; Garcia et al. 2002; Amaral et al. 2008), share a pericentric inversion of a submetacentric chromosome formed by 14/15a association, resulting in the form 14/15a/14. In particular, *C. capucinus* presents the most conserved karyotype among all Platyrrhini (Richard et al. 1996; Garcia et al. 2002; Amaral et al. 2008), while the other gracile/un-tufted *Cebus* and the robust-tufted *Sapajus* species are more derived (Figure 2(a)). The karyotype of *C. albifrons* differs from that of *C. capucinus* by another pericentric inversion in the 14/15a human association which results in a metacentric chromosome with 15a/14/15a/14 in tandem, and by a fusion followed by a pericentric inversion involving the homologous-to-human chromosomes 15b and 8b (8/15/8) (Amaral et al. 2008). The *C. olivaceus* (also known as *C. nigrivittatus*) and *S. apella* subspecies group are linked by a chromosomal inversion homologous to human synteny 20; they differ through another diverse pericentric inversion in the association 14/15a/14, resulting in a metacentric chromosome, and an apomorphic robertsonian rearrangement in the chromosomes homologous to human 12 and 15b (12/15) in *C. olivaceus*; the interchromosomal rearrangements mentioned above (not shown in Figure 2) in *C. albifrons* and *C. olivaceus* ($2n = 52$) explain their different diploid number when compared with that of the other *Cebus* capuchin species ($2n = 54$) (Richard et al. 1996; Garcia et al. 2002; Amaral et al. 2008).

Chromosome painting on *Saimiri sciureus* shows the 2a/15b human association that could represent a link (synapomorphy) between marmosets and tamarins (Figure 2(a)), (Neusser et al. 2001; Dumas et al. 2005, 2007). Moreover, all species of the *Saimiri* genus possess the same diploid number of chromosomes, $2n = 44$, although pericentric inversions characterize three geographically distinct karyotypes (Ma et al. 1974; Jones & Ma 1975).

Chromosomal painting data on both marmosets and tamarins (callitrichids), specifically *Callithrix jacchus* (Sherlock et al. 1996; Neusser et al. 2001), *Cebuella pygmaea*, *Mico argentatus* (Neusser et al. 2001), *Saguinus oedipus* (Neusser et al. 2001) and *Leontopithecus chrysomelas* (Gerbault-Serreau et al. 2004), allow researchers to show the chromosomal associations phylogenetically linking these species (13/17/20, 13/9/22, 2a/15b), later confirmed by reciprocal chromosome painting (Dumas et al. 2007) (Figure 2(a)). In particular, comparative analysis permits us to identify *S. oedipus* as the sister group of the remaining callitrichids, having human synteny 1a and 10b not fused (Neusser et al. 2001); the other callitrichid species are

Table II. List of platyrrhine species analyzed using a molecular cytogenetic approach and considering the principal published classical cytogenetic data. Chromosome painting studies with human probes, reciprocal chromosome painting, and multidirectional probes (New World monkey probes used are reported in parentheses) are highlighted in bold. Notes: *Homo sapiens* (HSA), *Aotus nancymae* (ANA), *Lagothrix lagothrica* (LLA), *Saguinus oedipus* (SOE), *Callimico goeldii* (CGO), *Cebuella pygmaea* (CPY), *Mico argentatus* (MAR), *Saimiri sciureus* (SSC), *Callicebus donacophilus pallescens* (CPA).

<i>Cebidae</i>			
<i>Aotus nancymae</i>	54	C, G banding and NOR staining Multidirectional chromosome painting (HSA-ANA, LLA)	Pieczarka et al. (1992) Stanyon et al. (2004)
<i>A. karyomorphs</i>	50	Chromosome painting	Ruiz - Herrera et al. (2005)
<i>Aotus l. griseimembra</i>	54	Chromosome painting	Stanyon et al. (2011)
<i>Callimico goeldii</i>	47/48	G, C banding Multidirectional chromosome painting (HSA, SOE, LLA) Reciprocal chromosome painting (CGO-HSA)	Dutrillaux et al. (1988) Neusser et al. (2001) Dumas et al. (2007)
<i>Callithrix jacchus</i>	46	C, T and Q banding G banding and NOR staining G banding Chromosome painting Multidirectional chromosome painting (HSA, SOE, LLA)	Dutrillaux and Couturier (1981) Ardito et al. (1987) Seuanez et al. (1988) Sherlock et al. (1996) Neusser et al. (2001) Seuanez et al. (1988) Neusser et al. (2001) Dumas et al. (2007)
<i>Cebuella pygmaea</i>	44	G banding Multidirectional chromosome painting (HSA, SOE) Reciprocal chromosome painting (CPY-HSA)	Amaral et al. (2008) Nagamachi et al. (1997) Gerbault - Serreau et al. (2004)
<i>Cebus albifrons</i>	52	Multidirectional chromosome painting (HSA, SOE)	Dumas et al. (2007)
<i>Cebus capucinus</i>	54	Q, R, C banding and NOR staining Q, R, C banding and NOR staining G, R banding and NOR staining Chromosome painting	Dutrillaux (1979) Dutrillaux & Rumpler (1980) Garcia et al. (1983) Richard et al. (1996) Martinez et al. (1999) Garcia et al. (2002) Ruiz-Herrera et al. (2004)
<i>Cebus olivaceus (nigrivittatus)</i>	52	C banding G banding and chromosome painting G and C banding Chromosome painting	Amaral et al. (2008) Nagamachi et al. (1997) Gerbault - Serreau et al. (2004)
<i>Leontopithecus rosalia</i>	46	G banding	Pieczarka et al. (1996)
<i>Leontopithecus chrysomelas</i>	46	Chromosome painting	Nagamachi et al. (1997) Gerbault - Serreau et al. (2004)
<i>Mico argentatus</i>	44	C banding G, C and NOR banding G, C banding Multidirectional chromosome painting (HSA, SOE) Reciprocal chromosome painting (MAR- HSA)	Pieczarka et al. (1996) Nagamachi et al. (1996) Neusser et al. (2001) Dumas et al. (2007) Nagamachi et al. (1997b)
<i>Saguinus oedipus</i>	46	G banding Reciprocal Chromosome painting (HSA-SOE) Chromosome painting (LLA)	Muller et al. (2001) Neusser et al. (2001)
<i>Saimiri sciureus</i>	44	Giemsa C, T, and Q banding Chromosomal features C banding and NOR staining Chromosome painting Reciprocal chromosome painting (HSA-SSC)	Jones et al. (1975) Dutrillaux & Couturier (1981) Hershkovitz (1984) Moore et al. (1990) Stanyon et al. (2000) Dumas et al. (2007)
<i>Sapajus apella</i>	54	G, C banding and NOR staining C banding G, R banding and NOR staining G and C banding Q, C and G banding Chromosome painting	Freitas & Seuanez (1982) Garcia et al. (1983) Clemente et al. (1987) Matayoshi et al. (1987) Mudry et al. (1990) Garcia et al. (2002)
<i>Sapajus a. robustus</i>	54	Multidirectional chromosome painting (HSA, SOE)	Amaral et al. (2008)
<i>Sapajus a. paraguayanus</i>	54	Multidirectional chromosome painting (HSA, SOE)	Amaral et al. (2008)

(Continued)

Table II. (Continued).

<i>Atelidae</i>			
<i>Alouatta belzebul</i>	49/50	Chromosome painting	Consigliere et al. (1998)
<i>Alouatta caraya</i>	52	G banding C and G banding Multidirectional chromosome painting (HSA, SOE, LLA) Chromosome painting	Mudry et al. (1990) Mudry et al. (1998) De Oliveira et al. (2002) Stanyon et al. (2011)
<i>Alouatta fusca clamitans</i>	50	Multidirectional chromosome painting (HSA, SOE, LLA)	De Oliveira et al. (2002)
<i>Alouatta fusca fusca</i> (<i>guariba guariba</i>)	49/50	Chromosome painting	Stanyon et al. (2011)
<i>Alouatta sara</i>	50	G banding Chromosome painting	Stanyon et al. (1995) Consigliere et al. (1996)
<i>Alouatta seniculus arctoidea</i>	50 44/45	G banding Chromosome painting	Stanyon et al. (1995) Consigliere et al. (1996)
<i>Alouatta seniculus macconnelli</i>	52	Multidirectional chromosome painting (HSA, SOE, LLA)	De Oliveira et al. (2002)
<i>Ateles belzebuth marginatus</i>	34	C, G banding and NOR staining Multidirectional chromosome painting (HSA, SOE, LLA)	Medeiros et al. (1997) De Oliveira et al. (2005)
<i>Ateles belzebuth hybridus</i>			
<i>Ateles geoffroyi</i>	34	Chromosome painting	Morescalchi et al. (1997)
<i>Ateles paniscus paniscus</i>	32	C, G banding and NOR staining C, G banding and NOR staining Multidirectional chromosome painting (HSA, SOE, LLA)	Pieczarka, et al. (1989) Medeiros et al. (1997) De Oliveira et al. (2005)
<i>Brachyteles arachnoides</i>	62	C banding and NOR staining Multidirectional chromosome painting (HSA, SOE, LLA)	Viegas Pequignot et al. (1985) De Oliveira et al. (2005)
<i>Lagothrix lagotricha</i>	62	C banding Banding and NOR staining G and C banding Reciprocal chromosome painting (HSA-LLA)	Viegas Pequignot et al. (1985) Garcia et al. (1983) Clemente et al. (1987) Stanyon et al. (2001)
<i>Pitheciidae</i>			
<i>Cacajao calvus rubicundus</i>	45/46	C, G banding and NOR staining and Multidirectional chromosome painting (HSA, SOE)	Finotelo et al. (2010)
<i>Callicebus cupreus</i>	46	Multidirectional chromosome painting (HSA, CPA)	Dumas et al. (2005)
<i>Callicebus donacophilus pallescens</i>	50	Multidirectional chromosome painting (HSA, SOE)	Barros et al. (2003)
<i>Callicebus lugens</i>	16	G banding Chromosome painting	Bonvicino et al. (2003) Stanyon et al. (2003)
<i>Callicebus moloch</i>	50	Chromosome painting	Stanyon et al. (2000)
<i>Callicebus pallescens</i>	50	Chromosome painting Reciprocal chromosomal painting (HSA- CPA)	Stanyon et al. (2000) Dumas et al. (2005)
<i>Callicebus personatus</i>	44	C, G banding, NOR staining Chromosome painting	Rodrigues et al. (2004) Rodrigues et al. (2011)
<i>Chiropotes israelita</i>	54	G banding Chromosome painting	Bonvicino et al. (2003) Stanyon et al. (2004)
<i>Chiropotes satanas utahicki</i>	54	G banding G banding Chromosome painting	Seuanez et al. (1992) Bonvicino et al. (2003) Stanyon et al. (2004)
<i>Pithecia irrorata</i>	48	C, G banding and NOR staining and chromosome painting	Finotelo et al. (2010)

linked by the 1a/10b association. Particularly noteworthy is *Mico argentatus*, a species of the newly recognized genus, which shows the same chromosomal synteny with respect to *Cebuella pygmaea* (Neusser et al. 2001), but has a large amount of

heterochromatin at the terminal ends of two chromosomes; the *C. jacchus* karyotype differs from that of other species by a single fission. In particular, a comparison of classical cytogenetic data on tamarins, *Saguinus* and *Leontopithecus*, shows

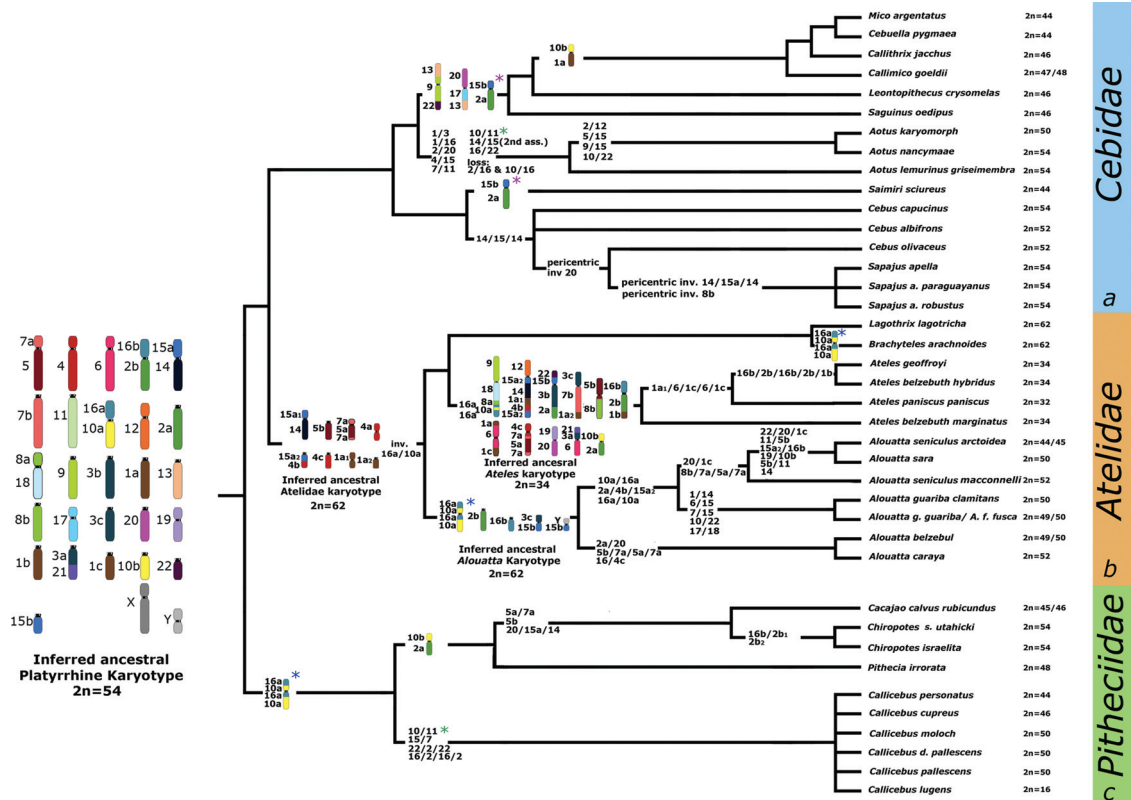

Figure 2. Platyrrhine molecular phylogenetic tree, modified from Perelman et al. (2011); this tree, drawn using the Mesquite program, reports human ancestral and new associations characterizing each principal node: Cebidae (a), Atelidae (b), and Pitheciidae (c). Chromosomes are numbered according to their homology with human chromosomes. We used Neusser and colleagues’ nomenclature (2001) for segment identification; note that not all associations represent real homologies, but only the ones confirmed by reciprocal chromosome painting. For example, peculiar associations indicated by (*), such as 2a/15b, 10/11, 16a/10a and 13/17/20, that link some taxa, conflict with molecular reconstructions and need to be analyzed through Bacterial Artificial Chromosome mapping in order to test if they constitute true homologies. The inversion breakpoints of the human 10a/16a association, presumably linking Atelidae and Pitheciidae, also have to be better analyzed.

that they have similar karyotypes (2n = 46) and differ only by para- and pericentric inversions detected on at least four acrocentric chromosomes (data not shown in Figure 2) (Nagamachi et al. 1997b; Neusser et al. 2001).

The *Callimico* genus – with one species, *Callimico goeldii*, whose phylogenetic position has been highly discussed – is characterized by a translocation involving the Y chromosome and an autosome. Consequently, males may have a diploid number of 47 or 48 chromosomes (Dutrillaux et al. 1988; Margulis et al. 1995). Chromosome painting permitted researchers to definitely demonstrate that *Callimico* is phylogenetically linked with *Callithrix* and *Cebuella* (marmosets) by sharing the same human chromosomal association 1a/10b (Neusser et al. 2001), which characterizes all callitrichids (Figure 2(a)), eliminating any previous doubts.

The taxonomy of the *Aotus* genus of owl monkeys has been debated since it was first described by the Spanish naturalist Félix de Azara in 1802, especially

in terms of the number of species and subspecies recognized. Initially, just one species was recognized, *Aotus trivirgatus*; subsequently, on the basis of chromosomal characteristics and geographical distribution, nine species and four subspecies have been recognized due to the presence of sibling species (species seemingly identical from a morphological point of view but which possess divergent karyotypes). The karyotypes of these species are characterized by many polymorphisms and a variable diploid number, ranging from 46 to 59 chromosomes (Galbreath 1983; Torres et al. 1998), with differences as well between males and females in the diploid number due to a translocation between chromosome Y and an autosome (Ma et al. 1976; Pieczarka & Nagamachi 1988). It has been suggested that the karyotypes of these species originated from the ancestral platyrrhine karyotype (2n = 54), passing through fissions, translocations and inversions (De Boer 1974; Ma et al. 1976; Mudry et al. 1984;

Pieczarka et al. 1992, 1993; Torres et al. 1998). Chromosome painting was first applied to metaphases of *Aotus nancymaae*, showing that the karyotype of owl monkeys is highly derived. Successively, two other *Aotus* karyotypes have been reconstructed: one of a karyomorph (Ruiz-Herrera et al. 2005) as well as that of *A. lemurinus griseimembra* (Stanyon et al. 2011). These three *Aotus* samples share the following derived associations: 1/3, 1/16, 2/20, 4/15, 7/11, 10/11, 14/15 twice and 16/22, and the loss of the ancestral New World monkey associations 2b/16b, 10a/16a (Figure 2(a)). Presumably the loss of the 10a/16a association occurred by fusion with synteny 22 and a successive inversion to give 10a/22/16a. *Aotus l. griseimembra* has the least derived karyotype, while the karyomorph and *A. nancymaae* share four derived associations (2/12, 5/15, 9/15, 10/22) indicating a sister-clade relationship between them (Stanyon et al. 2011). A peculiarity arises in the syntenic association 10/11 shown in the karyotypes of *Aotus* and *Callicebus* (Pitheciidae) (Dumas et al. 2005); this association could be either a real homology phylogenetically linking the two genera or a homoplastic result of convergent evolution, or even a hemiplasy; thus, further analyses are needed through Bacterial Artificial Chromosome mapping in order to test these possible explanations.

Atelidae family

Chromosomal painting data on *Lagothrix lagotricha* (Stanyon et al. 2001), *Ateles geoffroyi* (Morescalchi et al. 1997), *A. belzebuth hybridus* (Garcia et al. 2002), *A. paniscus paniscus*, *Brachyteles arachnoides* (De Oliveira et al. 2005) and six *Alouatta* species (Consigliere et al. 1996, 1998; De Oliveira et al. 2002; Stanyon et al. 2011) compared with the ancestral platyrrhine associations (3a/21, 5/7a, 10a/16a, 8a/18, 2b/16b, 14/15a) show that these are conserved in Atelidae. In addition, Atelidae exclusively share derived fissions of human chromosome homologs 1, 4, 5 and 15a that resulted in chromosome forms 1a1, 1a2, 4a, the association of 4b/15a2, 4c, the inversion 7a/5a/7a and 5b, 15a1/14, indicating the monophyletic origin of this group (Figure 2(b)). Thus, painting data allowed researchers to propose the hypothetical ancestral Atelidae karyotype ($2n = 62$), almost identical to those of *Lagothrix lagotricha* and *Brachyteles arachnoides* (Stanyon et al. 2001; De Oliveira et al. 2005); the two species, having the same karyotypes, are considered sister clades, differing by just five intrachromosomal rearrangements detected by G banding (data not shown in Figure 2) (Stanyon et al. 2001; De Oliveira et al. 2005).

While painting data support the monophyly of Atelidae, they do not help in resolving the branching genera sequence. In support of the previous approach, classical cytogenetic data analysis on Atelidae permitted researchers to identify a derived inversion involving the 10a/16a association linking *Alouatta*, *Brachyteles* and *Lagothrix*, resulting in 16a/10a/16a/10a, which was presumably lost in *Ateles* which instead presents the association 16a/10a/16a; moreover, researchers have formulated an evolutionary tree with four branches in the following order, *Alouatta*, *Brachyteles*, *Lagothrix*, and *Ateles*, due to two inversions of human synteny 8b linking *Brachyteles*, *Lagothrix* and *Ateles*, and of human synteny 13 linking *Lagothrix* and *Ateles* (De Oliveira et al. 2005). These inversions need to be further tested with BAC probes to check whether they share the same breakpoints and can be considered real homologies.

Neither the taxonomy nor the phylogenetic relationships within the genus *Alouatta* are clear, and there is no agreement among researchers; indeed, from nine to 19 species have been recognized. The classical cytogenetic studies allowed researchers to highlight in this genus a large variation in the diploid number, from $2n = 44$ to $2n = 58$, and two unusual features: a system of multiple sex chromosomes involving a translocation between Y chromosomes and an autosome (Ma et al. 1975; Armada et al. 1987; Mudry et al. 1998, 2001; Steinberg et al. 2008), and the presence of various microchromosomes (Lima & Seuánez 1991), probably composed of repetitive DNA. In the *Alouatta* genus, *Alouatta sara* and *A. seniculus arctoidea* were the first New World monkey species to be analyzed through chromosome painting (Consigliere et al. 1996). They are characterized by high chromosomal variability; indeed, the chromosomal rearrangements responsible for the differences between the karyotypes of these two species are two robertsonian translocations, five tandem translocations and five intrachromosomal rearrangements. Later, human chromosomal probes hybridized on metaphases of *Alouatta belzebul* (Consigliere et al. 1996) permitted researchers to show a less rearranged karyotype than the species mentioned above. Chromosome painting has been performed on more species: *A. fusca guariba* (De Oliveira et al. 2002; Stanyon et al. 2011), *A. caraya*, *A. seniculus macconnelli* (De Oliveira et al. 2002) and *A. g. clamitans* (Stanyon et al. 2011). Through these works, it has been shown that the *Alouatta* monophyletic group is linked by a Y-autosomal translocation (Y/15b) as well as by the loss of the ancestral association 2b/16b and the presence of the association 3c/15b (except in *A.*

belzebul). Through these studies, it has also been possible to distinguish two species subgroups, one formed by *A. caraya* and *A. belzebul* linked by human associations 2a/20, 5b/7a/5a/7a and 4c/16, while *A. seniculus arctoidea*, *A. s. macconnelli*, *A. sara* and *A. g. guariba* are linked by the 2a/4b/15a2 association and the fission resulting in the double 10a/16a associations (Consigliere et al. 1996, 1998; De Oliveira et al. 2002; Stanyon et al. 2011). Moreover, *A. seniculus arctoidea*, *A. s. macconnelli* and *A. sara* are linked by the associations 20/1c, 8b/7a/5a/7a, while *A. guariba guariba* and *A. g. clamitans* are linked by the syntenic associations 1/14, 6/15, 7/15, 10/22 and 17/18 (De Oliveira et al. 2002) (Figure 2(b)).

The diploid number of *Ateles* species varies from 32 to 34 chromosomes (Pieczarka et al. 1989; Morescalchi et al. 1997). The karyotypes of *Ateles geoffroyi* (Morescalchi et al. 1997) and *Ateles belzebuth hybridus* studied by chromosome painting (Garcia et al. 2002) differ only by inversions. Chromosome painting was also applied to *A. paniscus paniscus* and *A. belzebuth marginatus*, allowing researchers to reconstruct the hypothetical karyotype of all atelids, characterized by a highly reshuffled genome with human associations 9/18/8a/16a/10a/16a, 12/15a2/14/1a1/4b/15a2, 22/15b/3b/2a, 3c/7b/1a2, 5b/8b, 16b/2b/1b, 10b/2a, 1a/6/1c, 4c/7a/5a/7a, 19/20 and 21/3a/6 (Figure 2(b)). Moreover, on the basis of classical cytogenetic analysis, a tree with the following branches has been proposed: *A. belzebuth marginatus*, *A. paniscus paniscus*, *A. belzebuth hybridus* and *A. geoffroyi*, with the last three species linked by the inversion of the 1a1/6/1c/6/1c association present in the ancestral atelid karyotype; *A. belzebuth hybridus* and *A. geoffroyi* are further linked by an inversion of the ancestral 16b/2b/16b/2b/1b association (De Oliveira et al. 2005).

Pitheciidae family

The first comparative cytogenetic studies on representatives of the pitheciide families, including *Pithecia irrorata*, *Chiropotes satanas chiropotes*, *Chiropotes satanas utahicki* and *Cacajao calvus rubicundus*, showed their monophyly (Moura-Pensin et al. 2001).

Human chromosome probes hybridized to *Chiropotes utahicki* and *C. israelita* gave the same pattern of hybridization, and comparison with the ancestral hypothetical platyrrhine karyotype indicates the *Chiropotes* karyotype is very conserved (Stanyon et al. 2004). Classical and molecular cytogenetics have also been applied to *Pithecia irrorata* ($2n = 48$) and *Cacajao calvus rubicundus* ($2n = 45$ in males, $2n = 46$ in females) using human and *Saguinus oedipus* whole chromosome probes (Finotelo et al.

2010). These analyses indicate that the chromosomal differences found among these three taxa are consequences of centric fusions and fissions, pericentric and paracentric inversions, tandem fusions and a Y-autosome translocation; furthermore, these three species are linked by the 2a/10b human association, and *Chiropotes* and *Cacajao* are linked by a fission of the ancestral New World association 5/7a (giving association 5a/7a and synteny 5b) and by a fusion leading to the association of human synteny 20/15a/14 (Figure 2(c)). It should be noted that the 5/7a fission in pitheciide species and in Atelidae is a homoplasy since it has already been shown that they have different breakpoints (De Oliveira et al. 2005; Finotelo et al. 2010). In addition, an inversion of the human association 10a/16a has been found in *Chiropotes*, *Pithecia* and *Cacajao* through G banding data analysis; this result apparently is a synapomorphic feature linking all pitheciids (including *Callicebus*) (Finotelo et al. 2010), so this association is worthy of further investigation in order to test whether the same breakpoints are shared by the different species.

For *Callicebus*, from 28 to 32 species have been recognized (Van Roosmalen et al. 2002; Van Roosmalen & Van Roosmalen 2013), with chromosomal diploid numbers ranging from 16 chromosomes in *C. lugens* (Bonvicino et al. 2003) to 50 chromosomes in *C. donacophilus pallescens*, *C. pallescens* and *C. hoffmannsi* (De Boer 1974; Minezawa & Borda 1984; Stanyon et al. 2000; Rodrigues et al. 2001). *Callicebus lugens* is the species with the most derived karyotype and lowest diploid number of chromosomes found among all primates. Chromosome painting has been applied to six *Callicebus* species – *Callicebus moloch*, *C. lugens*, *C. cupreus*, *C. pallescens*, *C. d. pallescens* and *C. personatus* (Stanyon et al. 2000, 2003; Barros et al. 2003; Dumas et al. 2005; Rodrigues et al. 2011) – showing that fusions are the predominant rearrangements responsible for the karyotype evolution of these species; moreover, it has been shown that three new human associations, 7/15, 10/11 and 22/2, and two inversions involving the 2/22 (22/2/22) and 16/2 human associations (16/2/16/2), characterize the hypothetical ancestral *Callicebus* karyotype (Figure 2(c)). Apart from these ancestral associations shared by all of the species analyzed, further comparison permits the identification of other specific associations and arrangements, such as: 12/19 linking all species but *C. lugens*; 13/17 present in *C. cupreus*, *C. pallescens*, and *C. d. pallescens*; 17/20 association present in all species except *C. d. pallescens*, *C. personatus* and *C. moloch*; 9/7/5a shared by *C. cupreus* and *C. d. pallescens* (not reported in Figure 2). These

analyses also permitted the demonstration that *C. pallescens* is a different taxon if compared with *C. d. pallescens*, and therefore it is possible to assume that they are two different species (Dumas et al. 2005). The data discussed highlight very highly rearranged karyotypes among *Callicebus* species; however, from the data gathered so far, it has not been possible to find any human syntenic associations, apart from the above-mentioned inversion of human association 10a/16a, linking *Callicebus* to other pitheciids. On the other hand, the 13/17 association found in *Callicebus* needs further investigation since a similar association has been found in callitrichids (Cebidae), although, as unpublished data suggest, this could be the result of convergent evolution (De Oliveira et al. 2012). Moreover, as mentioned previously, the 10/11 associations found in *Callicebus* could be a cytogenetic link with *Aotus* (Cebidae), so they must be better analyzed in order to test breakpoints and real homology.

Conclusion

The taxonomic and phylogenetic relationships of Platyrrhini have been difficult to reconstruct on the basis of morphological characteristics because of problems in distinguishing homology from convergence. On the other hand, at the molecular level, difficulties in finding accurate relationships within and among taxa have been probably due to a rapid separation of lineages during radiation and the low number of nucleotide differences between species. Indeed, even if phylogenetic reconstructions agree regarding the identification of three main branches – Pitheciidae, Atelidae, Cebidae – their relationships are still debated, as are some unresolved nodes at inter- and intrageneric levels as well. In this perspective, classical and molecular cytogenetics are useful tools to help in the phylogenetic reconstruction of New World monkeys.

In this work, we review the molecular cytogenetic data available in the literature for principal nodes of the platyrrhine tree, also considering informative chromosomal banding patterns; this analysis has permitted us to report the main objectives reached so far through this approach and to discuss divergent data in respect to recent molecular claims. The principal issues are listed below:

1. Classical and molecular cytogenetics have shown that Neotropical primates are karyologically significantly variable and derivative with respect to the average of primates (one rearrangement for every 10 million years), but with clear differences between families.

2. Comparative cytogenetics indicates that the biodiversity of this group of species is not entirely known, for example as has been demonstrated with the description of diverse species of owl monkeys (*Aotus*), howler monkeys (*Alouatta*) and titi monkeys (*Callicebus*). This situation may occur because New World monkeys often present a condition of “sibling species”.
3. Chromosome painting has permitted researchers to show the monophyly of New World primates since all share the syntenic associations 8a/18, 10a/16a, 2b/16b, 5/7a (Neusser et al. 2001) characterizing the hypothetical platyrrhine ancestral karyotype (2n = 54); these results are also supported through reciprocal chromosome painting applied to *Lagothrix lagothricha* (Stanyon et al. 2001), *Saguinus oedipus* (Müller et al. 2001), *Aotus nancymae* (Stanyon et al. 2004), *Callicebus pallescens* (Dumas et al. 2005), *Mico argentatus* (*Callithrix argentata*), *Cebuella pygmaea*, *Callimico goeldii* and *Saimiri sciureus* (Dumas et al. 2007).
4. The *Cebus* (Cebidae) karyotype is the most similar to that of the hypothetical ancestral platyrrhine, but *Chiropotes* (Pitheciidae) also shows a conserved karyotype. On the other hand, among Atelidae highly derived karyotypes have been found, especially in *Ateles* and *Alouatta*. Moreover, *Callicebus* species (Pitheciidae) also show highly derived karyotypes.
5. Tamarins and marmosets (callitrichids, Cebidae) constitute a monophyletic group sharing the following derived chromosomal associations: 13/17/20, 13/19/22 and 2a/15b. The 2/15b human syntenic association of marmosets and tamarins has also been found in *Saimiri sciureus*, indicating a possible link between them; since molecular data instead link *Saimiri* to *Cebus*, BAC mapping is required to test whether this 2a/15b association may represent a real synapomorphy, or homoplasy (the result of a convergence event).
6. Chromosome painting has resolved the debate on the phylogenetic placement of *Callimico goeldii* (Cebidae). The presence of the human association 1a/10b phylogenetically links *Callimico* to marmosets (Neusser et al. 2001), in agreement with molecular data.
7. Even if the position of *Callicebus* among Pitheciidae is supported at the molecular level, only an inversion of the 16a/10a ancestral platyrrhine association permits the inference of a cytogenetic link with other

Pitheciids, while on the other hand the syntenic associations 13/17 and 17/20 present in some *Callicebus* species could link this genus with callitrichids (Cebidae). As seen in the case of *Saimiri*, all of these associations (inv 10a/16a, 13/17, 17/20) are worthy of further investigation to test for real homologies, or the presence of homoplasy, or if they could be explained as consequences of hemiplasy.

8. The phylogenetic relationships of *Aotus* among Cebidae has always been controversial when reconstructed through molecular and morphological data. Even from a cytogenetic point of view, no synapomorphies have been detected to link it to the *Cebus/Saimiri* clade or to the callitrichids. On the contrary, the 10/11 associations instead link owl monkeys (Cebidae) and *Callicebus* (Pitheciidae), even if molecular analyses do not provide similar evidence. In addition, this association needs to be checked in order to verify whether it shares identical breakpoints and could, then, represent a real synapomorphy, or whether it could be homoplasy or hemiplasy.
9. The 10a/16a inversion present in Atelidae and Pitheciidae also needs further investigation in order to test whether it shares the same breakpoints and there could thus be a synapomorphy between the two families, or if it could instead be a homoplasy.
10. No human associations have been provided to corroborate the molecular phylogenetic recognition of two new genera, *Mico* and *Sapajus*, apart from some intrachromosomal rearrangements. The same is true for *Leontocebus* (*S. fuscicollis*), as no molecular cytogenetic mapping has so far been performed on it.

In conclusion, we would like to stress the importance of recognizing hemiplasy because “phylogenetic discordance” due to chromosomal traits could be explained through evolutionary interpretations that take into account homology or homoplasy not only due to convergence or parallelism but also due to polymorphisms in random lineage sorting. For example, the human associations reported above which link Cebidae and Pitheciidae (10/11) or Pitheciidae and Atelidae (inv 10a/16a), apparently in discordance, could be considered a consequence of polymorphic lineage sorting rather than a contrast, as previously hypothesized (De Oliveira et al. 2012). Moreover due to the demonstrated complexity of the evolutionary radiation in Neotropical monkeys, we emphasize the necessity

of employing multidisciplinary and comparative approaches in order to clarify phylogenetic assessments.

Acknowledgements

Thanks to the “Fondazione Intesa San Paolo Onlus” which supported us by funding the project on “Evoluzione genomica in Primates” (2016-NAZ-0012, CUP:B72F16000130005) to FD.

Funding

This work was supported by “Fondazione Intesa San Paolo Onlus” [2016-NAZ-0012, CUP: B72F16000130005].

References

- Amaral PJS, Finotelo LFM, De Oliveira EHC, Pissinati A, Nagamachi CY, Piezarka JC. 2008. Phylogenetic studies of the genus *Cebus* (Cebidae-Primates) using chromosome painting and G-banding. *BMC Evolutionary Biology* 8:169–178. DOI:10.1186/1471-2148-8-169.
- Ardito G, Lamberti L, Bigatti P, Stanyon R, Govone D. 1987. NOR distribution and satellite associations in *Callithrix jacchus*. *Caryologia* 40:185–194. DOI:10.1080/00087114.1987.10797822.
- Armada JL, Barroso CM, Lima M, Muniz JAP, Seuánez HN. 1987. Chromosome studies in *Alouatta belzebul*. *American Journal of Primatology* 13:283–296. DOI:10.1002/ajp.1350130306.
- Avisé JC, Robinson TJ. 2008. Hemiplasy: A new term in the lexicon of phylogenetics. *Systematic Biologists* 57:503–507. DOI:10.1080/10635150802164587.
- Barros RM, Nagamachi CY, Piezarka JC, Rodrigues LRR, Neusser M, De Oliveira EHC, Wienberg J, Muniz JAPC, Rissino DJ, Müller S. 2003. Chromosomal studies in *Callicebus donacophilus pallescens*, with classic and molecular cytogenetic approaches: Multicolour FISH using human and *Saguinus oedipus* painting probes. *Chromosome Research* 11:327–334. DOI:10.1023/A:1024039907101.
- Bonvicino CR, Boubli JP, Otazú IB, Almeida FC, Nascimento FF, Coura JR, Seuánez HN. 2003. Morphologic, karyotypic, and molecular evidence of a new form of *Chiropotes* (Primates, Pitheciinae). *American Journal of Primatology* 61:123–133. DOI:10.1002/ajp.v61:3.
- Buckner JC, Alfaro JW, Raylands AB, Alfaro ME. 2014. Biogeography of the marmosets and tamarins (Callitrichidae). *Molecular Phylogenetics and Evolution* 82:413–425. DOI:10.1016/j.ympev.2014.04.031.
- Canavez F, Alves G, Fanning TG, Seuánez HN. 1996. Comparative karyology and evolution of the Amazonian *Callithrix* (Platyrrhini, Primates). *Chromosoma* 104:348–357. DOI:10.1007/BF00337224.
- Canavez F, Moreira MA, Bonvicino CR, Parham P, Seuánez HN. 1998. Comparative gene assignment in *Ateles paniscus chamek* (Platyrrhini, Primates) and man: Association of three separate human syntenic groups and evolutionary considerations. *Chromosoma* 107:73–79. DOI:10.1007/s004120050282.
- Canavez FC, Moreira MAM, Bonvicino CR, Parham P, Seuánez HN. 1999a. Evolutionary disruptions of human syntenic groups 3, 12, 14, and 15 in *Ateles paniscus chamek*

- (Platyrrhini, Primates). Cytogenetic and Genome Research 87:182–188. DOI:10.1159/000015461.
- Canavez FC, Moreira MAM, Simon F, Parham P, Seuánez HN. 1999b. Phylogenetic relationships of the Callitrichinae (Platyrrhini, Primates) based on β -2 microglobulin sequences. American Journal of Primatology 48:225–236. DOI:10.1002/(SICI)1098-2345(1999)48:3<225::AID-AJP4>3.0.CO;2-4.
- Clemente IC, Garcia M, Ponsà M, Egozcue J. 1987. High resolution chromosome banding studies in *Cebus apella*, *Cebus albifrons*, and *Lagothrix lagothricha*: Comparison with the human karyotype. American Journal of Primatology 13:23–36. DOI:10.1002/ajp.1350130105.
- Consigliere S, Stanyon R, Koehler U, Agoramoorthy G, Wienberg J. 1996. Chromosome painting defines genomic rearrangements between red howler monkey subspecies. Chromosome Research 4:264–270. DOI:10.1007/BF02263675.
- Consigliere S, Stanyon R, Koehler U, Arnold N, Wienberg J. 1998. *In situ* hybridization (FISH) maps chromosomal homologies between *Alouatta belzebul* (Platyrrhini, Cebidae) and other primates and reveals extensive interchromosomal rearrangements between howler monkey genomes. American Journal of Primatology 46:119–133. DOI:10.1002/(SICI)1098-2345(1998)46:2<119::AID-AJP2>3.0.CO;2-Z.
- Cortés-Ortiz L, Bermingham E, Rico C, Rodríguez-Luna E, Sampaio I, Ruiz-García M. 2003. Molecular systematics and biogeography of the Neotropical monkey genus, *Alouatta*. Molecular Phylogenetics and Evolution 26:64–81. DOI:10.1016/S1055-7903(02)00308-1.
- De Boer LEM. 1974. Cytotaxonomy of the Platyrrhini (Primates). Genen En Phaenen 17:1–115.
- De Oliveira EH, Neusser M, Figueiredo WB, Nagamachi C, Pieczarka JC, Sbalqueiro IJ, Wienberg J, Müller S. 2002. The phylogeny of howler monkeys (*Alouatta*, Platyrrhini): Reconstruction by multicolor cross-species chromosome painting. Chromosome Research 10:669–683. DOI:10.1023/A:1021520529952.
- De Oliveira EH, Neusser M, Müller S. 2012. Chromosome evolution in New World monkeys (Platyrrhini). Cytogenetic and Genome Research 137:259–272. DOI:10.1159/000339296.
- De Oliveira EH, Neusser M, Pieczarka JC, Nagamachi C, Sbalqueiro IJ, Müller S. 2005. Phylogenetic inferences of Atelinae (Platyrrhini) based on multi-directional chromosome painting in *Brachyteles arachnoides*, *Ateles paniscus paniscus* and *Ateles b. marginatus*. Cytogenetic and Genome Research 108:183–190. DOI:10.1159/000080814.
- Dumas F, Bigoni F, Stone G, Sineo L, Stanyon R. 2005. Mapping genomic rearrangements in titi monkeys by chromosome flow sorting and multidirectional *in-situ* hybridization. Chromosome Research 13:85–96. DOI:10.1007/s10577-005-7063-y.
- Dumas F, Stanyon R, Sineo L, Stone G, Bigoni F. 2007. Phylogenomics of species from four genera of New World monkeys by flow sorting and reciprocal chromosome painting. BMC Evolutionary Biology 7(Suppl 2):S11. DOI:10.1186/1471-2148-7-S2-S11.
- Dutrillaux B. 1979. Chromosomal evolution in primates: Tentative phylogeny from *Microcebus murinus* (Prosimian) to man. Human Genetics 48:251–314. DOI:10.1007/BF00272830.
- Dutrillaux B. 1988. New interpretation of the presumed common ancestral karyotype of platyrrhine monkeys. Folia Primatologica 50:226–229. DOI:10.1159/000156348.
- Dutrillaux B, Couturier J. 1981. The ancestral karyotype of Platyrrhini monkeys. Cytogenetics and Cell Genetics 30:232–242. DOI:10.1159/000131614.
- Dutrillaux B, Couturier J, Viegas-Pequignot E. 1986. Evolution chromosomique des Platyrrhiniens. Mammalia 50:56–81.
- Dutrillaux B, Lombard M, Carroll JB, Martin RD. 1988. Chromosomal affinities of *Callimico goeldii* (Platyrrhini) and characterization of a Y-autosome translocation in the male. Folia Primatologica 50:230–236. DOI:10.1159/000156349.
- Dutrillaux B, Rumpler Y. 1980. Chromosome banding analogies between a prosimian (*Microcebus murinus*), a platyrrhine (*Cebus capucinus*), and man. American Journal of Physical Anthropology 52:133–137. DOI:10.1002/(ISSN)1096-8644.
- Finotelo LF, Amaral PJ, Pieczarka JC, De Oliveira EH, Pissinati A, Neusser M, Müller S, Nagamachi CY. 2010. Chromosome phylogeny of the subfamily Pitheciinae (Platyrrhini, Primates) by classic cytogenetics and chromosome painting. BMC Evolutionary Biology 10:189. DOI:10.1186/1471-2148-10-189.
- Freitas L, Seuánez H. 1982. Chromosome heteromorphisms in *Cebus apella*. Journal of Human Evolution 11:173–180. DOI:10.1016/S0047-2484(82)80050-X.
- Froenicke L. 2005. Origins of primate chromosomes – as delineated by Zoo-FISH and alignments of human and mouse draft genome sequences. Cytogenetic and Genome Research 108:122–138. DOI:10.1159/000080810.
- Galbreath GJ. 1983. Karyotypic evolution in *Aotus*. American Journal of Primatology 4:245–251. DOI:10.1002/(ISSN)1098-2345.
- García F, Nogués C, Ponsà M, Ruiz-Herrera A, Egozcue J, García Caldes M. 2000. Chromosomal homologies between humans and *Cebus apella* (Primates) revealed by ZOO-FISH. Mammalian Genome 11:399–401. DOI:10.1007/s003350010075.
- García F, Ruiz-Herrera A, Egozcue M, Ponsà M, García M. 2002. Chromosomal homologies between *Cebus* and *Ateles* (Primates) based on ZOO-FISH and G-banding comparison. American Journal of Primatology 57:177–188. DOI:10.1002/ajp.10047.
- García M, Miró R, Estop A, Ponsà M, Egozcue J. 1983. Constitutive heterochromatin polymorphism in *Lagothrix lagothricha cana*, *Cebus apella*, and *Cebus capucinus*. American Journal of Primatology 4:117–126. DOI:10.1002/ajp.1350040203.
- Gerbault-Serreau M, Bonnet-Garnier A, Richard F, Dutrillaux B. 2004. Chromosome painting comparison of *Leontopithecus chrysomelas* (Callitrichine, Platyrrhini) with man and its phylogenetic position. Chromosome Research 12:691–701. DOI:10.1023/B:CHRO.0000045754.43803.db.
- Hershkovitz P. 1984. Taxonomy of squirrel monkey genus *Saimiri* (Cebidae, Platyrrhini): A preliminary report with description of a hitherto unnamed form. American Journal of Primatology 6:257–312. DOI:10.1002/ajp.1350060402.
- Horovitz I, Zardoya R, Meyer A. 1998. Platyrrhine systematics: A simultaneous analysis of molecular and morphological data. American Journal of Physical Anthropology 106:261–281. DOI:10.1002/(ISSN)1096-8644.
- Jones TC, Ma NSF. 1975. Cytogenetics of the squirrel monkey (*Saimiri sciureus*). In: Primate research. Vol. 6. FASEB monographs. London: Springer. pp. 13–21.
- Kiesling NMJ, Soojin VY, Xu K, Sperone FG, Wildman DE. 2015. The tempo and mode of new world monkey evolution and biogeography in the context of phylogenomic analysis. Molecular Phylogenetics and Evolution 82:386–399. DOI:10.1016/j.ympev.2014.03.027.
- Lima MMC, Sampaio I, Vieira RD, Schneider H. 2007. Spider monkey, muriqui and woolly monkey relationships revisited. Primates 48:55–63. DOI:10.1007/s10329-006-0012-3.
- Lima MMC, Seuánez HN. 1991. Chromosome studies in the red howler monkey, *Alouatta seniculus stramineus* (Platyrrhini,

- Primates): Description of a X1X2Y1Y2/X1X1X1X2X2 sex chromosome system and karyological comparisons with other subspecies. *Cytogenetics and Cell Genetics* 57:151–156. DOI:10.1159/000133135.
- Lynch Alfaro JW, Boubli JP, Olson LE, Di Fiore A, Wilson B, Gutiérrez-Espeleta GA, Chiou KL, Schulte M, Neitzel S, Ross V, Schwochow D. 2012a. Explosive Pleistocene range expansion leads to widespread Amazonian sympatry between robust and gracile capuchin monkeys. *Journal of Biogeography* 39:272–288. DOI:10.1111/j.1365-2699.2011.02609.x.
- Lynch Alfaro JW, Silva JD, Rylands AB. 2012b. How different are robust and gracile capuchin monkeys? An argument for the use of *Sapajus* and *Cebus*. *American Journal of Primatology* 74:273–286. DOI:10.1002/ajp.22007.
- Ma NSF, Elliott MW, Morgan L, Miller A, Jones TC. 1976. Translocation of Y chromosome to an autosome in the Bolivian owl monkey, *Aotus*. *American Journal of Physical Anthropology* 45:191–201. DOI:10.1002/(ISSN)1096-8644.
- Ma NSF, Jones TC, Thorington RW, Cooper RW. 1974. Chromosome banding patterns in squirrel monkeys (*Saimiri sciureus*). *Journal of Medical Primatology* 3:120–137.
- Ma NSF, Jones TC, Thorington RW, Miller AC, Morgan L. 1975. Y-autosome translocation in the Howler Monkey (*Alouatta palliata*). *Journal of Medical Primatology* 4:299–307.
- Margulis SW, Chin J, Warneke M, Dubach JM, Lindgren V. 1995. The Y- autosome translocation of *Callimico goeldii*. *International Journal of Primatology* 16:145–155. DOI:10.1007/BF02700157.
- Martinez R, Aguilera M, Ferreirab C. 1999. The karyotype and C-banding of *Cebus nigrovittatus* from the Coastal Cordillera, Venezuela. *Folia Primatologica* 70:37–40. DOI:10.1159/000021673.
- Matayoshi T, Seuáñez HN, Nasazzi N, Nagle C, Armada JL, Freitas L, Alves G, Barroso CM, Howlin E. 1987. Heterochromatic variation in *Cebus apella* (Cebidae, Platyrrhini) of different geographic regions. *Cytogenetic and Genome Research* 44:158–162. DOI:10.1159/000132362.
- Medeiros MA, Barros RMS, Pieczarka JC, Nagamachi CY, Ponsa M, Garcia M, Garcia F, Egozcue J. 1997. Radiation and speciation of spider monkeys, genus *Ateles*, from the cytogenetic viewpoint. *American Journal of Primatology* 42:167–178. DOI:10.1002/(ISSN)1098-2345.
- Minezawa M, Borda CJV. 1984. Cytogenetic study of the Bolivian titi and revision of its cytotaxonomy state. *Kyoto University Overseas Research Report of New World Monkeys* 4:39–45.
- Moore CM, Harris CP, Abec CR. 1990. Distribution of chromosomal polymorphisms in three subspecies of squirrel monkeys (genus *Saimiri*). *Cytogenetic and Genome Research* 53:118–122. DOI:10.1159/000132909.
- Moreira MAM. 2002. SRY evolution in Cebidae (Platyrrhini: Primates). *Journal of Molecular Evolution* 55:92–103. DOI:10.1007/s00239-001-2308-7.
- Moreira MAM, Almeida CAS, Canavez F, Olicio R, Seuáñez HN. 1996. Heteroduplex mobility assays (HMAs) and analogous sequence analysis of a cytochrome b region indicate phylogenetic relationships of selected callitrichids. *Journal of Heredity* 87:456–460. DOI:10.1093/oxfordjournals.jhered.a023037.
- Moreira MAM, Seuáñez HN. 1999. Mitochondrial pseudogenes and phyletic relationships of *Cebuella* and *Callithrix* (Platyrrhini, Primates). *Primates* 40:353–364. DOI:10.1007/BF02557558.
- Morescalchi MA, Schempp W, Consigliere S, Bigoni F, Wienberg J, Stanyon R. 1997. Chromosome painting in the new world monkey, *Ateles geoffroyi*, the black-handed spider monkey. *Chromosome Research* 5:527–536. DOI:10.1023/A:1018489602312.
- Moura-Pensin C, Pieczarka JC, Nagamachi CY, Muniz JAPC, Brígido MCO, Pissinati A, Marinho ANR, Barros RMS. 2001. Cytogenetic relations among the genera of the subfamily Pitheciinae (Cebidae, Primates). *Caryologia* 54:385–391. DOI:10.1080/00087114.2001.10589250.
- Mudry MD. 1990. Cytogenetic variability within and across Populations of *Cebus apella* in Argentina. *Folia Primatologica* 54:206–216. DOI:10.1159/000156445.
- Mudry MD, Colillas OJ, Brioux De Salum S. 1984. The *Aotus* from northern Argentina. *Primates* 25:530–537. DOI:10.1007/BF02381674.
- Mudry MD, Rahn IM, Solari AJ. 2001. Meiosis and chromosome painting of sex chromosome systems in Ceboidea. *American Journal of Primatology* 54:65–78. DOI:10.1002/(ISSN)1098-2345.
- Mudry MD, Rahn M, Gorostiaga M, Hick A, Merani MS, Solari AJ. 1998. Revised karyotype of *Alouatta caraya* (Primates: Platyrrhini) based on synaptonemal complex and banding analyses. *Hereditas* 128:9–16. DOI:10.1111/j.1601-5223.1998.00009.x.
- Müller S, Neusser M, O'Brien PCM, Wienberg J. 2001. Molecular cytogenetic characterization of the EBV-producing cell line B95-8 (*Saguinus oedipus*, Platyrrhini) by chromosome sorting and painting. *Chromosome Research* 9:689–693. DOI:10.1023/A:1012960525326.
- Mundy NI, Kelly J. 2001. Phylogeny of lion tamarins (*Leontopithecus* spp.) based on interphotoreceptor retinol binding protein intron sequences. *American Journal of Primatology* 54:33–40. DOI:10.1002/(ISSN)1098-2345.
- Murphy WJ, Larkin DM, Van Der Wind AE, Bourque G, Tesler G, Auviel L, Beever JE, Chowdhary BP, Galibert F, Gatzke L, Hitte C, Meyers SN, Milan D, Ostrander EA, Pape G, Parker HG, Raudsepp T, Rogatcheva MB, Schook LB, Skow LC, Welge M, Womack JE, O'Brien SJ, Pevzner PA, Lewin HA. 2005. Dynamics of mammalian chromosome evolution inferred from multispecies comparative maps. *Science* 309:613–617. DOI:10.1126/science.1111387.
- Nagamachi CY, Pieczarka JC, Barros RMS, Schwarz M, Muniz JAPC, Mattevi MS. 1996. Chromosomal relationships and phylogenetic and clustering analyses on genus *Callithrix*, group *argentata* (Callitrichidae, Primates). *Cytogenetic and Genome Research* 72:331–338. DOI:10.1159/000134216.
- Nagamachi CY, Pieczarka JC, Muniz JA, Barros RM, Mattevi MS. 1999. Proposed chromosomal phylogeny for the South American primates of the Callitrichidae family (Platyrrhini). *American Journal of Primatology* 49:133–152. DOI:10.1002/(SICI)1098-2345(199910)49:2<133::AID-AJP5>3.0.CO;2-6.
- Nagamachi CY, Pieczarka JC, Schwarz M, Barros RM, Mattevi MS. 1997a. Comparative chromosomal study of five taxa of genus *Callithrix*, group *jacchus* (Platyrrhini, Primates). *American Journal of Primatology* 41:53–60. DOI:10.1002/(SICI)1098-2345(1997)41:1<53::AID-AJP5>3.0.CO;2-Z.
- Nagamachi CY, Pieczarka JC, Schwarz M, Barros R, Mattevi MS. 1997b. Chromosomal similarities and differences between tamarins, *Leontopithecus* and *Saguinus* (Platyrrhini, Primates). *American Journal of Primatology* 43:265–276. DOI:10.1002/(SICI)1098-2345(1997)43:3<265::AID-AJP6>3.0.CO;2-V.
- Neusser M, Wienberg J, Stanyon R, Müller S. 2001. Molecular cytogenetics of Platyrrhini – comparative analysis of five species by multicolour reciprocal chromosome painting gives evidence for a classification of *Callimico goeldii* with Callitrichidae. *Cytogenetics and Cell Genetics* 94:206–215. DOI:10.1159/000048818.

- Opazo JC, Wildman DE, Prychitko T, Johnson RM, Goodman M. 2006. Phylogenetic relationships and divergence times among new world monkeys (Platyrrhini, Primates). *Molecular Phylogenetics and Evolution* 40:274–280. DOI:10.1016/j.ympev.2005.11.015.
- Osterholz M, Walter L, Roos C. 2009. Retropositional events consolidate the branching order among new world monkey genera. *Molecular Phylogenetics and Evolution* 50:507–513. DOI:10.1016/j.ympev.2008.12.014.
- Pastorini J, Forstner MRJ, Martin RD, Melnick DJ. 1998. A reexamination of the phylogenetic position of *Callimico* (Primates) incorporating new mitochondrial DNA sequence data. *Journal of Molecular Evolution* 47:32–41. DOI:10.1007/PL00006360.
- Perelman P, Johnson WE, Roos C, Seuánez HN, Horvath JE, Moreira MAM, Kessing B, Pontius J, Roelke M, Rumpler Y, Schneider MPC, Silva A, O'Brien SJ, Pecon-Slattery J. 2011. A molecular phylogeny of living primates. *PLoS Genetics* 3:e1001342. DOI:10.1371/journal.pgen.1001342.
- Perez SI, Klaczko J, Dos Reis SF. 2012. Species tree estimation for a deep phylogenetic divergence in the new world monkeys (Primates: Platyrrhini). *Molecular Phylogenetics and Evolution* 65:621–630. DOI:10.1016/j.ympev.2012.07.014.
- Pieczarka JC, De Souza Barros RM, De Faria FMJR, Nagamachi CY. 1993. *Aotus* from the southwestern Amazon region is geographically and chromosomally intermediate between *A. azarae boliviensis* and *A. infulatus*. *Primates* 34:197–204. DOI:10.1007/BF02381390.
- Pieczarka JC, De Souza Barros RM, Nagamachi CY, Rodrigues R, Espinel A. 1992. *Aotus vociferans* × *Aotus nancymai*: Sympatry without chromosomal hybridization. *Primates* 33:239–245. DOI:10.1007/BF02382753.
- Pieczarka JC, Nagamachi CY. 1988. Cytogenetic studies of *Aotus* from eastern Amazonia: Y/autosome rearrangement. *American Journal of Primatology* 14:255–263. DOI:10.1002/ajp.1350140306.
- Pieczarka JC, Nagamachi CY, Barros RMS. 1989. The karyotype of *Ateles paniscus paniscus* (Cebidae, Primates): 2n= 32. *Revista Brasileira De Genética* 12:543–551.
- Pieczarka JC, Nagamachi CY, Barros RMS, Mattevi MS. 1996. Analysis of constitutive heterochromatin by fluorochromes and in situ digestion with restriction enzymes in species of the group *Callithrix argentata* (Callitrichidae, Primates). *Cytogenetic and Genome Research* 72:325–330. DOI:10.1159/000134215.
- Porter CA, Czelusniak J, Schneider H, Schneider MPC, Sampaio I, Goodman M. 1997. Sequences of the primate ϵ -globin gene: Implications for systematics of the marmosets and other New World primates. *Gene* 205:59–71. DOI:10.1016/S0378-1119(97)00473-3.
- Ray DA, Xing J, Hedges DJ, Hall MA, Laborde ME, Anders BA, White BR, Stoilova N, Fowlkes JD, Landry KE, Chemnick LG, Ryder OA, Batzer MA. 2005. Alu insertion loci and platyrrhine primate phylogeny. *Molecular Phylogenetics and Evolution* 35:117–126. DOI:10.1016/j.ympev.2004.10.023.
- Richard F, Lombard M, Dutrillaux B. 1996. ZOO-FISH suggests a complete homology between human and capuchin monkey (Platyrrhini) euchromatin. *Genomics* 36:417–423. DOI:10.1006/geno.1996.0486.
- Robinson TJ, Ruiz-Herrera A, Avise JC. 2008. Hemiplasy and homoplasy in the karyotypic phylogenies of mammals. *Proceedings of the National Academy of Sciences of the United States of America* 105:14477–14481. DOI:10.1073/pnas.0807433105.
- Rodrigues LRR, Barros R, Pissinati A, Pieczarka JC, Nagamachi CY. 2004. A new karyotype of an endangered primate species (*Callicebus personatus*) from the Brazilian Atlantic forests. *Hereditas* 140:87–91. DOI:10.1111/j.1601-5223.2004.01793.x.
- Rodrigues LRR, Barros RMS, Pissinati A, Pieczarka JC, Nagamachi CY. 2001. Cytogenetic study of *Callicebus hoffmannsii* (Cebidae, Primates) and comparison with *C. m. moloch*. *Cytobios* 105:137–145.
- Rodrigues LRR, Pieczarka JC, Pissinati A, De Oliveira EHC, Das Doreas Rissino J, Nagamachi CY. 2011. Genomic mapping of human chromosome paints on the threatened masked Titi monkey (*Callicebus personatus*). *Cytogenetic and Genome Research* 133:1–7. DOI:10.1159/000323956.
- Rokas A, Holland PW. 2000. Rare genomic changes as a tool for phylogenetics. *Trends in Ecology & Evolution* 15:454–459. DOI:10.1016/S0169-5347(00)01967-4.
- Ruiz-Herrera A, García F, Aguilera M, Garcia M, Ponsá Fontanals M. 2005. Comparative chromosome painting in *Aotus* reveals a highly derived evolution. *American Journal of Primatology* 65:73–85. DOI:10.1002/ajp.v65:1.
- Ruiz-Herrera A, García F, Aguilera M, Garcia M, Ponsá M. 2004. New polymorphisms in a *Cebus* (Platyrrhini, Primates) species. The case of *Cebus nigrivittatus*. *Caryologia* 57:206–209. DOI:10.1080/00087114.2004.10589394.
- Sampaio R, Röhe F, Pinho G, Silva-Júnior JD, Farias IP, Rylands AB. 2015. Re-description and assessment of the taxonomic status of *Saguinus fuscicollis cruzlimai* Hershkovitz, 1966 (Primates, Callitrichinae). *Primates* 56:131–144. DOI:10.1007/s10329-015-0458-2.
- Schneider H, Bernardi JA, Da Cunha DB, Tagliaro CH, Vallinoto M, Ferrari SF, Sampaio I. 2012. A molecular analysis of the evolutionary relationships in the Callitrichinae, with emphasis on the position of the dwarf marmoset. *Zoologica Scripta* 41:1–0. DOI:10.1111/j.1463-6409.2011.00502.x.
- Schneider H, Canavez FC, Sampaio I, Moreira MA, Tagliaro CH, Seuánez HN. 2001. Can molecular data place each neotropical monkey in its own branch? *Chromosoma* 109:515–523. DOI:10.1007/s004120000106.
- Schneider H, Sampaio I. 2015. The systematics and evolution of New World primates—A review. *Molecular Phylogenetics and Evolution* 82:348–357. DOI:10.1016/j.ympev.2013.10.017.
- Schneider H, Sampaio I, Harada ML, Barroso CML, Schneider MPC, Czelusniak J, Goodman M. 1996. Molecular phylogeny of the New World monkeys (Platyrrhini, Primates) based on two unlinked nuclear genes: IRBP intron 1 and ϵ -globin sequences. *American Journal of Physical Anthropology* 100:153–179. DOI:10.1002/(ISSN)1096-8644.
- Schneider H, Schneider MPC, Sampaio MIC, Harada ML, Stanhope M, Czelusniak J, Goodman M. 1993. Molecular phylogeny of the new world monkeys (Platyrrhini, Primates). *Molecular Phylogenetics and Evolution* 2:225–242. DOI:10.1006/mpev.1993.1022.
- Seuánez HN, Alves G, Lima MMC, Barros R, Barros CML, Muniz JAPC. 1992. Chromosome studies in *Chiropotes satanas utahicki* Hershkovitz, 1985 (Cebidae, Platyrrhini): A comparison with *Chiropotes satanas chiropotes*. *American Journal of Primatology* 28:213–222. DOI:10.1002/(ISSN)1098-2345.
- Seuánez HN, Forman L, Alves G. 1988. Comparative chromosome morphology in three Callitrichid genera: *Cebuella*, *Callithrix* and *Leontopithecus*. *Journal of Heredity* 79:418–424.
- Seuánez HN, Lima CR, Lemos B, Bonvicino CR, Moreira MA, Canavez FC. 2001. Gene assignment in *Ateles paniscus chamek* (Platyrrhini, Primates). Allocation of 18 markers of human syntenic groups 1, 2, 7, 14, 15, 17 and 22. *Chromosome Research* 9:631–639. DOI:10.1023/A:1012900206671.

- Sherlock JK, Griffin DK, Delhanty JDA, Parrington JM. 1996. Homologies between human and marmoset (*Callithrix jacchus*) chromosomes revealed by comparative chromosome painting. *Genomics* 33:214–219. DOI:10.1006/geno.1996.0186.
- Singer SS, Schmitz J, Schwiegk C, Zischler H. 2003. Molecular cladistic markers in new world monkey phylogeny (Platyrrhini, Primates). *Molecular Phylogenetics and Evolution* 26:490–501. DOI:10.1016/S1055-7903(02)00312-3.
- Stanyon R, Arnold N, Koehler U, Bigoni F, Wienberg J. 1995. Chromosomal painting shows that “marked chromosomes” in lesser apes and Old World monkeys are not homologous and evolved by convergence. *Cytogenetic and Genome Research* 68:74–78. DOI:10.1159/000133894.
- Stanyon R, Bigoni F, Slaby T, Müller S, Stone G, Bonvicino CR, Neusser M, Seuánez HN. 2004. Multi-directional chromosome painting maps homologies between species belonging to three genera of New World monkeys and humans. *Chromosoma* 113:305–315. DOI:10.1007/s00412-004-0320-6.
- Stanyon R, Bonvicino CR, Svartman M, Seuánez HN. 2003. Chromosome painting in *Callicebus lugens*, the species with the lowest diploid number (2n=16) known in primates. *Chromosoma* 112:201–206. DOI:10.1007/s00412-003-0261-5.
- Stanyon R, Consigliere S, Bigoni F, Ferguson-Smith M, O’Brien PCM, Wienberg J. 2001. Reciprocal chromosome painting between a New World primate, the woolly monkey, and humans. *Chromosome Research* 9:97–106. DOI:10.1023/A:1009274802086.
- Stanyon R, Consigliere S, Müller S, Morescalchi A, Neusser M, Wienberg J. 2000. Fluorescence in situ hybridization (FISH) maps chromosomal homologies between the dusky titi and squirrel monkey. *American Journal of Primatology* 50:95–107. DOI:10.1002/(SICI)1098-2345(200002)50:2<95::AID-AJPM1>3.0.CO;2-8.
- Stanyon R, Garofalo F, Steinberg ER, Capozzi O, Di Marco S, Nieves M, Archidiacono N, Mudry MD. 2011. Chromosome painting in two genera of South American monkeys: Species identification, conservation, and management. *Cytogenetics and Genome Research* 13:40–50. DOI:10.1159/000324415.
- Stanyon R, Rocchi M, Capozzi O, Roberto R, Misceo D, Ventura M, Cardone MF, Bigoni F, Archidiacono N. 2008. Primate chromosome evolution: Ancestral karyotypes, marker order and neocentromeres. *Chromosome Research* 16:17–39. DOI:10.1007/s10577-007-1209-z.
- Steinberg ER, Cortés-Ortiz L, Nieves M, Bolzán AD, García-Orduña F, Hermida-Lagunes J, Canales-Espinosa D, Mudry MD. 2008. The karyotype of *Alouatta pigra* (Primates: Platyrrhini): Mitotic and meiotic analyses. *Cytogenetic and Genome Research* 122:103–109. DOI:10.1159/000163087.
- Tagliaro CH, Schneider MP, Schneider H, Sampaio IC, Stanhope MJ. 1997. Marmoset phylogenetics, conservation perspectives, and evolution of the mtDNA control region. *Molecular Biology and Evolution* 14:674–684. DOI:10.1093/oxfordjournals.molbev.a025807.
- Torres OM, Enciso S, Ruiz F, Silva E, Yunis I. 1998. Chromosome diversity of the genus *Aotus* from Colombia. *American Journal of Primatology* 44:255–275. DOI:10.1002/(ISSN)1098-2345.
- Van Roosmalen MG, Van Roosmalen T, Mittermeier RA. 2002. A taxonomic review of the titi monkeys, genus *Callicebus* Thomas, 1903, with the description of two new species, *Callicebus bernhardi* and *Callicebus stephennashi*, from Brazilian Amazonia. *Neotropical Primates* 10(Suppl):1–52.
- Van Roosmalen MGM, Van Roosmalen T. 2013. On the origin of allopatric primate species and the principle of metachromatic bleaching. E-book. Published privately. Available: <https://www.createspace.com/4549738>. Accessed March 2016.
- Viegas-Pequignot EV, Koiffmann CP, Dutrillaux B. 1985. Chromosomal phylogeny of *Lagothrix*, *Brachyteles*, and *Cacajao*. *Cytogenetic and Genome Research* 39:99–104. DOI:10.1159/000132115.
- Von Dornum M, Ruvolo M. 1999. Phylogenetic relationships of the New World Monkeys (Primates, Platyrrhini) based on nuclear G6PD DNA sequences. *Molecular Phylogenetics and Evolution* 11:459–476. DOI:10.1006/mpev.1998.0582.
- Wienberg J, Jauch A, Stanyon R, Cremer T. 1990. Molecular cytogenetics of primates by chromosomal in situ suppression hybridization. *Genomics* 8:347–350. DOI:10.1016/0888-7543(90)90292-3.
- Wienberg J, Stanyon R. 1995. Chromosome painting in mammals as an approach to comparative genomics. *Current Opinion in Genetics & Development* 5:792–797. DOI:10.1016/0959-437X(95)80013-U.
- Wildman DE, Jameson NM, Opazo JC, Yi SV. 2009. A fully resolved genus level phylogeny of neotropical primates (Platyrrhini). *Molecular Phylogenetics and Evolution* 53:694–702. DOI:10.1016/j.ympev.2009.07.019.