

## Meso-modeling of heterogeneous structures via interphase model

G. Giambanco<sup>1</sup>, A. Spada<sup>1</sup>, G. Fileccia Scimemi<sup>1</sup>

<sup>1</sup> *Department of Structural, Aerospace and Geotechnical Engineering, University of Palermo, Italy*  
e-mails: *ggiamb@unipa.it, antonino.spada@unipa.it, giuseppe.filecciascimemi@unipa.it*

All those structures that are constituted by heterogeneous materials, such as masonry structures and composite laminates, exhibit a complex anisotropic behaviour strictly related to the static and kinematic phenomena occurring in each constituent and at their interfaces. The overall macroscopic approach to the analysis of structures made up of heterogeneous material consists in formulating phenomenological constitutive laws expressed in terms of macroscopic stress and average strain for the equivalent homogeneous continuum. This way to operate in some cases may be not appropriate to describe the elastic and post-elastic response of the structures since it requires the introduction of strong simplifications. In particular, most of the nonlinearities of the overall response depend on local phenomena occurring between components such as debonding, sliding and dilatancy.

The meso-modelling approach is more rigorous since it considers the material as a discontinuous assembly of units and joints with their own geometry and constitutive properties. The joints in most cases represent the weakness areas of the heterogeneous material where fractures appear and propagate. In the case of adhesive joints a thin layer of a third material connects two or more units and its thickness is usually small if compared with the other dimensions of the assembly. In literature, a common way to simulate the thin joint is by applying the so-called 'zero-thickness interface'.

With reference to Fig. 1 the contact layer of thickness  $h$ , composed by the third material and by the two physical interfaces  $\Sigma^+$  and  $\Sigma^-$  collapses to its middle surface  $\Sigma$  where the contact tractions and the discontinuous displacements represent the static and kinematical quantities regulating the joint response. Therefore, the interface constitutive laws, elastic or inelastic, are relations between the above cited static and kinematic quantities.

However, in many cases the joint response depends also on internal stresses and strains within the third material. A typical example is the squeezing effect of the mortar joint interposed between two rigid blocks and subjected to a compression load.

In this direction the enhancement of the zero-thickness interface is represented by the interphase model. By employing the term interphase, we shall mean a layer separated by two interfaces from the bulk material or a multilayer structure with varying properties and several interfaces.

Two main assumptions are included into the model. The first one assumes that the fibers inside the interphase along the  $z$ -direction during the deformation process continue to remain rectilinear. The second one considers a constant strain state along the thickness of the joint because of its small dimension. The kinematical and equilibrium equations are written in matrix form as:

$$\hat{\boldsymbol{\varepsilon}} = \frac{1}{h} \mathbf{A}_1 (\mathbf{u}^+ - \mathbf{u}^-) + \frac{1}{2} \mathbf{A}_2 (\mathbf{u}^+ + \mathbf{u}^-)$$

$$\mathbf{t}^+ = \hat{\boldsymbol{\sigma}} \cdot \mathbf{I}_3 - \frac{h}{2} \text{div} \hat{\boldsymbol{\sigma}}, \quad \mathbf{t}^- = -\hat{\boldsymbol{\sigma}} \cdot \mathbf{I}_3 - \frac{h}{2} \text{div} \hat{\boldsymbol{\sigma}} \quad \text{on } \Sigma$$

$$\mathbf{m} \cdot \hat{\boldsymbol{\sigma}} = \mathbf{0} \quad \text{on } \Sigma\text{'s boundary.}$$

In the equations given above  $\mathbf{u}^+$ ,  $\mathbf{u}^-$ ,  $\hat{\boldsymbol{\varepsilon}}$  and  $\hat{\boldsymbol{\sigma}}$  are the displacement vector in the surface  $\Sigma^+$ , the dis-

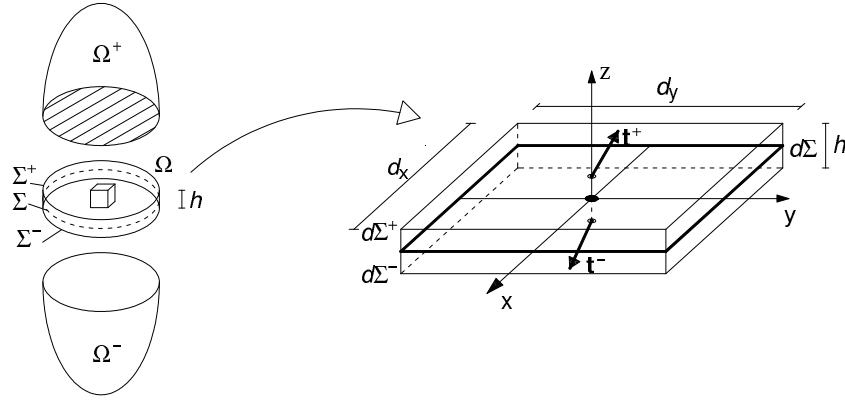

Figure 1: The interphase model

placement vector in the surface  $\Sigma^-$ , the strain and stress vectors in the interphase respectively.

Each one of these equations is written as the sum of two components. The first one refers to the interface response, the second one contains the additive terms obtained introducing internal state of stress and strain into the formulation.

The interphase model has been introduced as a new user element in the open-source finite element program FEAP [6]. The finite element is characterized by 4-node rectangular shaped and two or three Gauss or Lobatto points are used as quadrature rule. Strain and stresses at the interphase can be separated into internal and contact components and related to the nodal displacements by using:

$$\hat{\epsilon}^i = \mathbf{B}^i \mathbf{U}$$

$$\hat{\epsilon}^c = \mathbf{B}^c \mathbf{U}$$

where  $\mathbf{B}^i$  and  $\mathbf{B}^c$  are two matrices containing the derivatives of the form functions, and  $\mathbf{U}$  is the vector collecting the nodal displacements. The total strains at the integration point is given by

$$\hat{\epsilon} = \hat{\epsilon}^c + \hat{\epsilon}^i = \mathbf{B} \mathbf{U}$$

where  $\mathbf{B} = \mathbf{B}^c + \mathbf{B}^i$ .

Stresses, forces, and elastic stiffness matrix of the element are evaluated in the classical way.

Summarizing, in this work a mesoscale interphase model is presented. The constitutive laws of the interphase are written in terms of internal state of stresses and contact tractions and related kinematic variables. The model is implemented in a research oriented finite element code. Numerical simulations are provided to show the main features of the model and novelties introduced with respect to the common interface models.

## References

- [1] Spada, A., Giambanco, G., Rizzo, P., "Damage and Plasticity at the interfaces in composite materials and structures," *Computer Methods in Applied Mechanics and Engineering*, **198**, 3884-3901 (2009).
- [2] Giambanco, G., Rizzo, S., Spallino, R., "Numerical analysis of masonry structures via interface models", *Computer Methods in Applied Mechanics and Engineering*, **190(49-50)**, 6493-6511 (2001).
- [3] Alfano, G., Sacco, E., "Combining interface damage and friction in a cohesivezone model", *International Journal for Numerical Methods in Engineering*, **68**, 542-582, (2006).
- [4] Giambanco, G., Mróz, Z., "The interphase model for the analysis of joint in rock masses and masonry structures," *Meccanica*, **36**, 111-130 (2001).
- [5] *Proceedings of the XIX Congresso AIMETA di Meccanica Teorica e Applicata*, Spada, A., Fileccia Scimemi, G., Giambanco, G., "The interphase model applied to simulate chemically bonded anchors", Ancona, 2009.
- [6] Taylor, R. L., "FEAP - - A Finite Element Analysis Program," *Version 7.5 User Manual*, (2005).