



Comparative life cycle assessment of alternating and direct current electric loads: The case study of a power supply unit

Sonia Longo ^{a,*}, Alberto Affranchi ^b, Maurizio Cellura ^a, Francesco Guarino ^a

^a Department of Engineering University of Palermo, Palermo, Italy

^b Center of Sustainability and Ecological Transition, University of Palermo, Palermo, Italy

ARTICLE INFO

Handling editor: Neven Duic

Keywords:

Building energy
Life cycle assessment
Microgrids
Power supply unit
Direct current loads
Environmental impacts

ABSTRACT

Distributed energy systems operating in direct current have potential benefits if compared with systems in alternating current, due to the reduction of energy conversions.

This study performs an energy analysis of an office building to estimate the potential energy benefits of replacing alternating current loads with direct ones. The results indicate that modest but measurable improvements in energy performance can be obtained, evidenced by a 1.27 % reduction in total energy consumption and 4.50 % decrease in computer-related use, a 1.62 % reduction in grid imports, a 2.16 % decline in PV energy exports, thereby enhancing overall energy efficiency and self-sufficiency. Moreover, the study aims to quantify the life cycle impacts reduction for electric loads in direct current, through the analysis of a computer's power supply unit. The results show that the impacts for the manufacturing stage, considering 17 categories, is between 15 % and 45 %. For both configurations the use phase impacts are predominant compared to manufacturing except for water use. The applied approach can be replicated for other electric loads and buildings to support the idea that direct current outperforms their counterparts in terms of energy and environmental performance and that direct current microgrids can be more sustainable also in a life-cycle perspective.

Nomenclature

Abbreviations

AC	Alternative Current
Ac	Acidification
DC	Direct Current
DES	Distributed Energy Systems
FE	Freshwater Eutrophication
FEtox	Freshwater Ecotoxicity
FRU	Fossil Resource Use
GER	Global Energy Requirement
GHG	Greenhouse gas
GWP	Global Warming Potential
H	Height
HTc	Human Toxicity, Cancer
HTnc	Human Toxicity, Non-Cancer
IR	Ionising Radiation
L	Length
LCA	Life Cycle Assessment
LU	Land Use
ME	Marine Eutrophication

(continued on next column)

(continued)

Abbreviations

MRU	Minerals And Metals Resource Use
ODP	Ozone Depletion Potential
PM	Particulate Matter
POF	Photochemical Ozone Formation
PSU	Power Supply Unit
PV	Photovoltaic
PWB	Printed Wiring Board
TE	Terrestrial Eutrophication
W	Width
WU	Water Use

1. Introduction

Distributed energy systems (DES), that integrate renewable energy technologies (e.g. photovoltaic panels or wind turbines), play an important role in the decarbonisation process of the economy [1]. A

This article is part of a special issue entitled: SDEWES 2024 published in Energy.

* Corresponding author.

E-mail address: sonia.longo@unipa.it (S. Longo).

<https://doi.org/10.1016/j.energy.2025.135749>

Received 2 December 2024; Received in revised form 22 February 2025; Accepted 20 March 2025

Available online 20 March 2025

0360-5442/© 2025 The Authors. Published by Elsevier Ltd. This is an open access article under the CC BY license (<http://creativecommons.org/licenses/by/4.0/>).

microgrid is a complex energy system that integrates multiple energy sources, including distributed generators, renewable sources, and energy storage systems, while also including controllable and non-controllable loads [2]. Microgrids can work isolated or connected to low or medium voltage distribution networks [3]. They represent a viable alternative to conventional centralized energy systems by integrating DES with smart loads and storage [4]. Indeed, large-scale traditional electric power systems heavily rely on fossil fuels, impeding greenhouse gas (GHG) emissions reduction [5]. Substituting centralized energy systems with distributed ones has some advantages [6]. In detail, small-scale renewable power technologies have been identified for achieving sustainable economic growth, contributing to energy security and reducing environmental impacts [7]. In addition, the integration of multiple energy systems, such as compressed air storage with solar energy, further enhances efficiency and reliability [8]. Microgrids based on photovoltaic (PV) panel or wind turbine represent a viable solution for providing reliable and sustainable energy access in off-grid regions, for instance, in rural areas in West Africa [9]. In addition, PV microgrids offer significant environmental and energy benefits compared to traditional energy options as shown in Ref. [10] for a model village in Kenya. Furthermore, decision-making tools such as GHG-LCA models help optimize the sustainability of smart mini-grids by assessing GHG emissions and improving their environmental performance, as seen in the Don Bosco mini-grid in Ghana [11]. More complex systems can include renewable energy sources, electrolyser, fuel cell, batteries and thermal energy storage [12]. An energy management model for island DC microgrids integrating offshore wind systems and hydrogen production, for example, is examined in Ref. [13]. Other authors introduced a design optimization and control framework for a large-scale hybrid solar/wind system, both with and without battery storage, connected to the grid [14]. Many authors also studied an optimization model for the integrated management of electric vehicle sharing systems and energy scheduling in microgrids, focusing on the synergy between transport and energy sectors. In detail, Yao et al. [15] proposed an integrated system for managing electric vehicle sharing operations and scheduling energy within the Internet of Vehicles, while other authors [16] introduced a methodology for optimally positioning energy hubs that include EV charging stations and renewable generation, maximizing economic and environmental benefits. Moreover, Rezaei et al. [17] focused on the economic management of energy and reserves in renewable microgrids with EV aggregators, using a robust optimization approach to ensure reliable and sustainable performance.

The installation of DES has the potential to reduce the peak load demand by integrating the grid supplies with energy from distributed systems. Avoided/reduced cost of transmission and distribution, improvement of energy security and providing energy access to facilities that cannot be connected to the electricity grid are also interesting aspects of DES [18].

Microgrids can be designed to support alternating current (AC) or direct current (DC) or hybrid AC/DC [19]. In the first typology of microgrids the distributed energy sources are connected to an AC bus as shown in Fig. 1. The units that generate energy in DC (e.g. PV panels) and units for energy storage use DC-to-AC inverters to be connected to the AC bus. Then, AC-to-DC rectifiers supply the energy to the DC loads. Both inverters and rectifiers are electric power converters but with opposite function: inverters convert DC to AC and rectifiers convert AC to DC.

DC microgrids have a DC bus and the AC-to-DC rectifiers help to connect AC generating units, while DC-to-AC inverters supply AC loads (Fig. 2). Hybrid microgrids integrate both AC and DC buses, with AC loads directly connected to the AC bus, while DC loads are interfaced through DC-DC power electronic converters to ensure voltage adaptation [21].

DC microgrids are characterized by a reduction of multiple energy conversions from AC to DC and vice versa [22]. This aspect implies improved energy efficiency and reduced losses; simplified

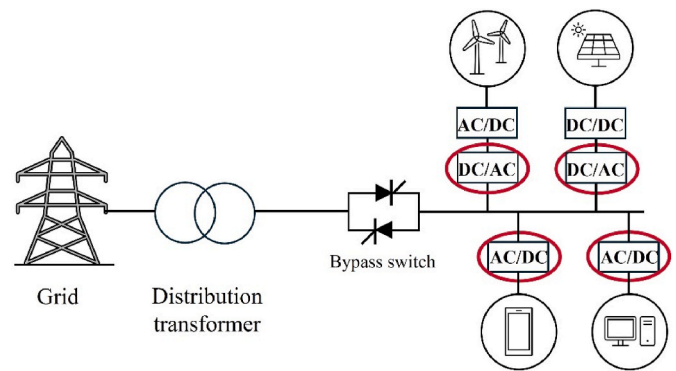

Fig. 1. AC microgrid configuration (Authors elaboration from Ref. [20]).

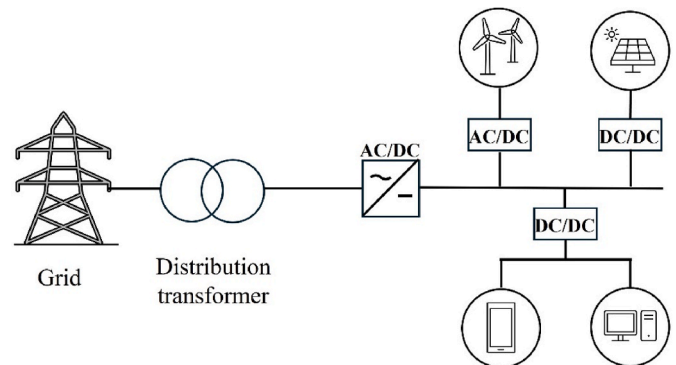

Fig. 2. DC microgrid configuration (Authors elaboration from Ref. [20]).

configurations and easier integration of various DC energy systems (e.g. energy storage and PV panels) to the common bus with simplified interfaces; less power converters; removal of internal components in the electric loads.

Resistive and power electronic interfaced energy loads operate in DC, such as computers, LED and fluorescent lamps, televisions, mobile phone chargers, etc. [23]. These loads use an internal DC link and an AC front-end to work with the AC grid.

In a microgrid operating directly in DC, some components such as rectifiers or power factor correction stages can be removed, with consequent costs reduction, efficiency increase, higher power density [24] and lower life-cycle energy and environmental impacts.

Different studies examined benefits of shifting from AC to DC microgrids. In particular.

- Gerber et al. [25] utilizing simulated models using real components showed that AC/DC boost converters with power ratings between 100 W and 500 W exhibit up to 2.5 times higher losses compared to DC/DC boost converters.
- Nagaraj [26] examined the decrease of power conversion losses in AC-DC hybrid microgrid studying different scenarios, under undistorted grid conditions, losses drop from 2080 W (AC coupled) to 751 W (AC-DC coupled), a 63 % reduction. In distorted grid conditions, losses decrease from 2906 W to 1035 W, improving efficiency by 64 %.
- Eskander and Silva [27] demonstrated that DC microgrid configuration offers high energy efficiency and CO₂ savings, but high appliance costs limit viability to high-consumption users. The dual AC-DC microgrid is cost-effective in Portugal, while in France, the dual hybrid AC-DC yields higher profits. The traditional AC microgrid remains the cheapest for low-consumption users but it is characterised by the lowest efficiency and CO₂ savings.

- Kumar et al. [20] described different features of DC microgrid, including advantages and disadvantages of this technology. The advantages include, for instance, the absence of skin effect in DC that allows full cable use, enabling smaller cables and reducing losses. In contrast, DC microgrid requires proper standardization, indeed, it is essential to guarantee voltage and safety standards, interoperability between DC microgrid and the various components (DES, storage system, and loads).

In the above studies detailed analyses of what happen in terms of life-cycle energy and environmental benefits to electric loads or to the buildings where electric loads are installed are missing or approximately, and existing environmental databases do not include information on the environmental aspects of DC loads. Thus, further researches are needed on this topic. Furthermore, most of the existing analyses on LCA of microgrid focus primarily on the main components of a microgrid (electric generators, inverters, storage systems), often neglecting smaller but essential elements (cables, converters, loads). However, the inclusion of these elements is crucial to ensure a comprehensive and consistent assessment of the energy and environmental impacts of microgrids.

To the author's knowledge, the environmental aspects of electric loads directly operating in DC were evaluated only by Kockel et al. [28] that based their study on existing data from environmental databases, which were modified to transform the AC loads in DC ones. In particular, the authors developed a comprehensive LCA comparing AC and DC microgrids in buildings using a scalable methodology. A generic grid model was developed defining three different building sizes (small, medium, and large), the comparative assessment was conducted focusing on different microgrid models in which some sub-components are included in one microgrid (AC) but absent in the other. The results indicate that DC microgrids can lead to significant reduction in environmental impacts, highlighting the importance of the considered energy mix. However, in the study only the total environmental impact of the microgrid is reported, while a detailed analysis of each component (including loads) is missing.

To fill the existing gap described above, and to evaluate the benefits of using electric loads that operate with DC microgrids in buildings, the aim of the study is.

- To develop an energy analysis of an office building where the loads are used, in order to estimate the energy benefits that can be obtained by substituting AC loads with DC ones;
- To quantify the life cycle impacts of a computer's power supply unit (PSU), used in the computers to convert high-voltage AC to low-voltage DC that works directly with energy fed by DC microgrid instead of by AC one. The analysis focused only on the electric load without considering the life cycle impacts of the entire microgrid infrastructure (that can be assumed the same for both the configurations).

The energy performance of the building is evaluated using dynamic building energy simulation, employing non-steady state calculations within the EnergyPlus environment. This method relies on measured data gathered through on-site investigations, which provided information on energy systems, lighting, equipment, occupancy levels, internal loads, the building envelope, and energy bills. The goal of the study is to analyse how the direct use of DC PSU affects the energy performance of a real office building, through the evaluation of energy indexes such as: the total electricity consumption, the electricity used by the computers, the imported and exported energy from the grid, and lastly the load cover factor.

The applied methodology for the environmental impacts analysis is the Life Cycle Assessment (LCA), a well-standardized approach that examines products and systems following a life-cycle approach and including their impacts generated during the whole value chain, from the raw materials extraction until the placing on the market, the use

phase and the end-of-life. The main LCA advantage is to draw a detailed overview of the product/system environmental impacts considering the whole life cycle, avoiding the "burden shifting" phenomenon and supporting the development of eco-design practices [29].

In the context of comparison between AC and DC technologies, LCA methodology provides a holistic framework that accounts for diverse environmental dimensions and enables the identification of energy and environmental hotspots [30]. This approach ensures that all stages of the life cycle, across several impact categories, are systematically analysed, thereby encouraging a more accurate and comprehensive comparison between the two technologies. The paper introduces innovative contributions compared to the state-of-the art, specifically, it examines the potential energy benefits of replacing AC PSUs with DC alternatives in an existing office building, conducting an energy analysis using measured data. Focusing on a specific electric load allows to develop a detailed analysis of the PSU and its components. Furthermore, the PSU modelling is based on primary data on materials and components that are part of the system, analysed at lab-scale through a detailed weighting process for obtaining a reliable mass balance. Moreover, by identifying the environmental hot spots of the PSU responsible for the highest impacts the study provides a foundation for defining eco-design strategies aimed at improving its environmental footprint. Additionally, the paper enriches the existing scientific literature with a new case study on energy analysis and LCA applied to DC loads, for which there is a lack of primary data.

The manuscript is organized as follows: the next section presents the materials and methods section in which the methodology is described, focusing on the building energy analysis and the LCA. Then section 3 presents the results of the analysis and at the end of the manuscript, the authors provide some final remarks.

2. Materials and methods

This section describes the adopted methodology, which can be summarized as follows: first, an office building model is introduced to evaluate the impact of implementing a directly DC-powered PSU within an office environment considering various energy performance indexes. Second, the LCA methodology is applied to the PSU, to compare the environmental impact of a traditional PSU and a directly DC one.

2.1. Building energy analysis

The application case used in this study is Building 9 of the Department of Engineering, located in Palermo. An aerial view of the building is shown in Fig. 3. The building is selected as a model of office building, it is characterised by a total area of 10,832.45 m², moreover, it is assumed that a 105 kWp PV plant with a total area of 942 m² is installed, constituted by single crystal silicon PV cells.

The building energy simulation is conducted using non-steady state calculations within EnergyPlus (version 9.6). Air temperature and heat flows are determined using the heat balance method. Internal loads, including lighting, occupants, and appliances, total electricity consumption and equipment-specific use, are based on data collected from the on-site investigation, use. Additionally, data on energy system use, schedules, and occupancy patterns are derived from on-site surveys, while data on PV electricity production derives from EnergyPlus simulation. The analysis aims to evaluate the impact of operating an entire building with DC PSUs. Two configurations are compared.

- The first is the traditional setup, in which the building operates on a conventional AC distribution system, where power is supplied by the grid and the photovoltaic plant, converted from AC to DC by individual PSUs.
- For the second configuration a direct DC power distribution system is assumed, eliminating AC-DC conversion losses by utilizing DC PSUs.

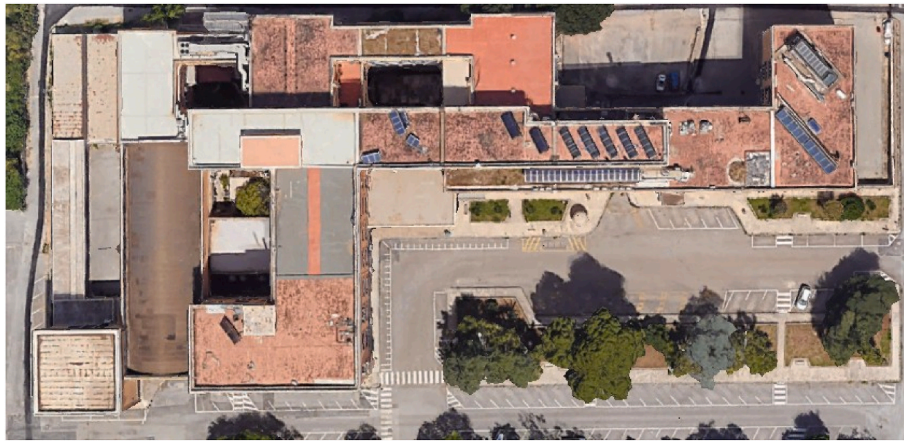

Fig. 3. Aerial view of Building 9.

It is assumed that, considering the building configuration, 70 % of the equipment-related energy consumption is attributable to computer use, for the second configuration a 4.5 % reduction of the computer energy consumption is applied [24]. Several energy performance indexes are analysed to evaluate the benefits for the entire building over a one-year period. First, in Eq. (1) is defined the difference of the total energy consumption of the two configurations:

$$\Delta C = \sum_{n=1}^{8760} C_{1n} - C_{2n} \quad (1)$$

Where,

- ΔC is the total difference in electricity consumption over the entire year between the two building configurations;
- C_{1n} represents the electricity consumption for the n-th hour for the first configuration;
- C_{2n} is the electricity consumption during the n-th hour for the second configuration.

Similarly, the same indicator is evaluated for the computers' energy consumption in Eq. (2):

$$\Delta P = \sum_{n=1}^{8760} P_{1n} - P_{2n} \quad (2)$$

In which,

- ΔP indicates the total difference in computers' electricity consumption over the entire year between the two building configurations;
- P_{1n} represents the electricity consumption during the n-th hour for the first configuration;
- P_{2n} is the electricity consumption for the n-th hour for the second configuration.

Eq. (3) shows the difference in imported energy from the grid for the two configurations (when the electricity consumption exceeds the PV electricity production):

$$\Delta I = \sum_{n=1}^{8760} (C_{1n} - E_{PV1n}) - (C_{2n} - E_{PV2n}) \quad (3)$$

In this case,

- ΔI represents the total difference in imported electricity from the grid over the entire year between the two building configurations;

- E_{PV1n} is the electricity produced by the PV plant during the n-th hour for the first configuration;
- E_{PV2n} indicates the electricity produced by the PV plant during the n-th hour for the second configuration.

Eq. (4) indicates the difference in exported energy from the PV plant to the grid for the two configurations (when the PV electricity production is higher than the consumption):

$$\Delta E = \sum_{n=1}^{8760} (E_{PV1n} - C_{1n}) - (E_{PV2n} - C_{2n}) \quad (4)$$

Where,

- ΔE is the total difference in exported electricity from the grid over the entire year between the two building configurations.

The Load Cover Factor (LCF) in Eq. (5) is an index that quantifies the fraction of the energy demand directly met by the photovoltaic system. The average LCF is calculated as:

$$LCF = \frac{\int_{t1}^{t2} \min[E_{PV}(t) - S(t) - \zeta(t), C(t)] dt}{\int_{t1}^{t2} C(t) dt} \quad (5)$$

- LCF represents the fraction of the energy demand directly covered by the PV system;
- $E_{PV}(t)$ is the electricity produced by the PV system at time t;
- $S(t)$ indicates the storage balance;
- ζ are the energy losses;
- $C(t)$ represents the electricity consumption at time t.

2.2. Life cycle assessment

In this paragraph, the case study of the PSU and the LCA methodology are described, in particular the LCA is conducted according to the international standards of series ISO 14040 [31] and 14044 [32] by applying an "attributitional approach". The attributitional approach describes the environmental properties of a system allocating elementary flows and potential environmental impacts as a detailed description of system history, without considering possible future variations among alternative product systems [33].

2.2.1. The case study of the PSU

The selected PSU is a 290 W, model DELL N° L290AM-00 (Fig. 4), the technical characteristics of the examined system are indicated in Table 1.

The base case PSU, examined through a lab-scale analysis, receives AC power from the grid and then converts it in DC by reducing the voltage to feed all the computer components. The second scenario is obtained removing sub-components of PSU responsible for AC-DC conversion, starting from previous literature studies [24].

The examined PSU is made up of a steel case, which has a protection function, in which are contained the fan, cables and the Printed Wiring Board (PWB); this component receives AC electrical energy from the grid and subsequently converts it in DC.

To obtain the bill of materials of the system, the base case AC PSU was completely disassembled, and all components were identified and weighted, with a focus on the PWB and its sub-components. To model the DC PSU, according to Stippich et al. [24] and Kockel et al. [28], the sub-components that convert AC in DC were identified and removed. As hypothesis, the cables and the fan were considered the same in both the scenarios, while the PWB's surface was considered 25 % less according to Ref. [24].

Focusing on the use phase, it was assumed that the electrical energy consumption during the operation is less than 4.5 % due to the absence of some components responsible for the AC-DC conversion [24]. The inventory analysis results are summarized in Table 2, that consists in the data collection (primary and secondary) to obtain all inputs and outputs [34]. Furthermore, Table 3 reports the main sub-components of the AC PWB, while the sub-components removed from the AC PWB for modelling the DC PWB are illustrated in Table 4.

2.2.2. Description of the applied LCA methodology

The total energy and environmental impacts are calculated and the components and materials responsible for the greatest impacts are identified through a contribution analysis.

The analysis follows a “cradle to use” approach and the system boundaries include the steps from the raw materials supply and sub-components production to the PSU assembly and use (Fig. 5).

The production of machinery and plants used in the PSU manufacturing, the transport of components to the factory, and the disposal phase are not included in this study. This exclusion is due to a lack of reliable data for these life cycle stages in the system under examination. Nevertheless, it is expected that the environmental benefits of the DC system would be even more substantial if these stages were accounted for, due to the smaller quantity of components required [28]. The transport processes are modelled considering a medium market distribution (from Ecoinvent). The model of both PSUs was created in the Simapro 9.5 LCA software [35] and the eco-profiles of the materials and

Table 1

Technical data of the computer's PSU.

Model	DELL N° L290AM-00
Dimension (W x L x H)	15 x 14 x 8.5 cm
AC Input	100–240 V/5.4 A
Input frequency range	50–60 Hz
DC Output	12 VA/14 A MAX 12 VB/16 A MAX 12 VSB/1.67 A MAX
Maximum continuous output power	290 W
Maximum operation temperature	50 °C

Table 2

Main component of the PSUs.

Cables and plug	AC PSU		DC PSU	
		kg		kg
	4.41E-02	kg	4.41E-02	kg
Fan	7.37E-02	kg	7.37E-02	kg
PWB	3.81E-01	kg	2.60E-01	kg
PWB's surface	1.72E-02	m ²	1.29E-02	m ²
Steel	5.67E-01	kg	5.67E-01	kg

Table 3

Sub-components of AC PWB.

Component	Mass (kg)
Aluminium heat sinks	7.42E-02
Capacitors	5.77E-02
Diodes	4.26E-03
Inductors	7.88E-02
Integrated circuit	4.94E-04
Resistors	2.55E-03
Transformers	6.51E-02
Transistors	1.14E-02

Table 4

Removed sub-components for DC PWB.

Component	Mass (kg)
Aluminium heat sinks	2.83E-02
Capacitors	4.98E-03
Diodes	8.60E-04
Inductors	7.80E-02
Resistors	1.16E-03
Transistors	7.67E-03

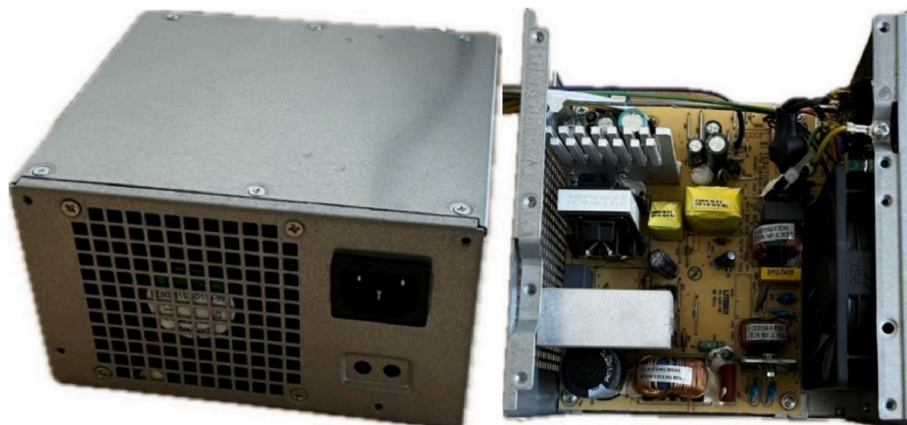

Fig. 4. The examined computer's PSU.

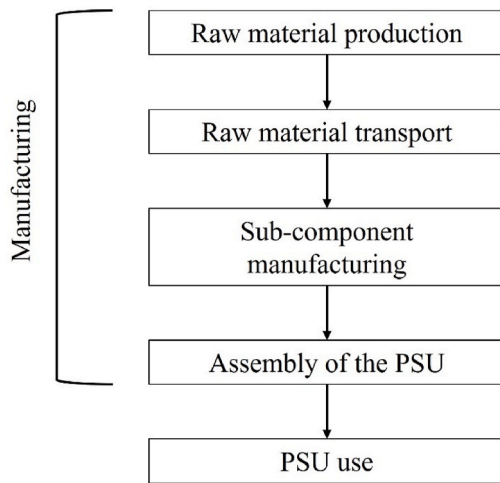

Fig. 5. System boundaries.

Table 5
Selected impact categories.

Impact Categories	Unit
Ac	mol H + eq
FRU	MJ
FE _{tox}	CTUe
FE	kg P _{eq}
GER	MJ
GWP	kg CO _{2eq}
HTc	CTUh
HTnc	CTUh
IR	kBq U-235 _{eq}
LU	Pt
ME	kg N _{eq}
MRU	kg Sb _{eq}
ODP	kg CFC11 _{eq}
PM	disease inc.
POF	kg NMVOC _{eq}
TE	mol N _{eq}
WU	m ³ _{depriv.}

components were identified based on the Ecoinvent database [36], referred to global context. Table 5 shows the energy and environmental indexes selected to calculate the eco-profiles of the two examined PSUs. The selected characterisation models are the Cumulative Energy Demand method [37] that quantify renewable and non-renewable primary energy consumption, and the EN15804 + A2 method [38] for the environmental analysis.

For the use phase, the following assumptions are made: the product lifespan is considered to be 10 years, with an operational time of 8 h per day over 250 days per year. The electric power for the AC PSU is 290 W, while for the DC PSU it was assumed an electricity consumption of 4.5 % less than the AC, as calculated by Stippich et al. [24]. In detail, in Ref. [24] a DC PSU was installed in a computer and the energy consumption was measured in idle mode, showing a reduction of 4.5 % compared to AC PSU. For the use phase, the impact assessment results are calculated considering two scenarios.

- Scenario 1: both PSUs use electricity from the Italian low voltage electricity mix (using the dataset from Ecoinvent [36] “Electricity, low voltage {IT} market for electricity, low voltage”);
- Scenario 2, AC PSU uses energy from the electricity mix while for DC PSU electricity is generated by PV (using the dataset from Ecoinvent [36] “Electricity, low voltage {IT} electricity production, photovoltaic, 3kWp slanted-roof installation, single-Si, panel, mounted).

3. Results

This section presents the main results, organised into the following subsections.

- Subsection 3.1 focuses on the results of the energy analysis of the building application case;
- Subsection 3.2 describes the life cycle impact assessment results and the interpretation.

3.1. Results of the building application case

This paragraph presents the results of the energy analysis applied to the building application case. Fig. 6 shows the electricity production and consumption during a typical winter week, in particular, the total electricity consumption ranges from 36 kWh to 129 kWh. Within this, equipment consumption varies from 16 to 56 kWh, while computer use ranges from 11 to 39 kWh. The PV electricity generation is between 0 and 61 kWh. Similarly, Fig. 7 illustrates a typical summer week, where both total electricity consumption and PV production increase. Specifically, the total consumption ranges from 37 to 155 kWh, and PV generation varies between 0 and 100 kWh. Equipment consumption is between 17 and 35 kWh, while computer use ranges from 12 to 24 kWh.

Table 6 shows the results of the calculation of the energy indexes described in Section 2.1.

The results highlight the impact of the proposed configuration on the building’s overall energy performance, in particular, the reduction in total energy consumption (C) between the two configuration amounts to 6.10 MWh, representing a 1.27 % decrease compared to the traditional configuration. When normalized by the building’s area, the specific consumption reduction is 0.56 kWh/m². This demonstrates a modest but measurable improvement in overall energy efficiency.

The reduction in computer-related energy consumption (P) corresponds to the total energy difference of 6.10 MWh, as this decrease is entirely attributable to P. However, when considering only computer consumption, the relative reduction is significantly higher at 4.50 %, compared to the overall (1.27 %).

The reduction in energy imported from the grid (I) is 5.60 MWh, equivalent to a 1.62 % decrease. The specific import reduction is 0.52 kWh/m². This decline indicates improved self-consumption of on-site PV generation and reduced dependency on external energy sources, enhancing energy autonomy.

Conversely, the exported energy from the PV system to the grid (E) experiences a slight decrease of 0.50 MWh, corresponding to a 2.16 % reduction and in a specific export decrease of 0.05 kWh/m². The negative values indicate an increased self-consumption of PV-generated energy contributing to improved efficiency and self-sufficiency.

The results demonstrate that implementing a direct DC power distribution system leads to slight but measurable energy savings in the context of an office building. Furthermore, the reduced grid import and increased self-consumption of PV energy support the effectiveness of the proposed approach in improving energy efficiency and sustainability. For both configurations, the LCF shows a minimal change, with Configuration 1 at 24.07 % and Configuration 2 at 24.24 %, reflecting a decrease of 0.17 %. While there is a slight improvement in the LCF, the magnitude of this change is marginal, indicating that the shift in self-sufficiency between the two configurations is not substantial.

Applying the same approach to other types of electrical loads, such as lighting or other plug loads, it is expected to achieve similar results, contributing to improve the overall energy efficiency of the building by reducing energy consumption and grid imports. Furthermore, this approach can be extended beyond the office building context to other building types or even to entire districts maximizing the potential energy savings.

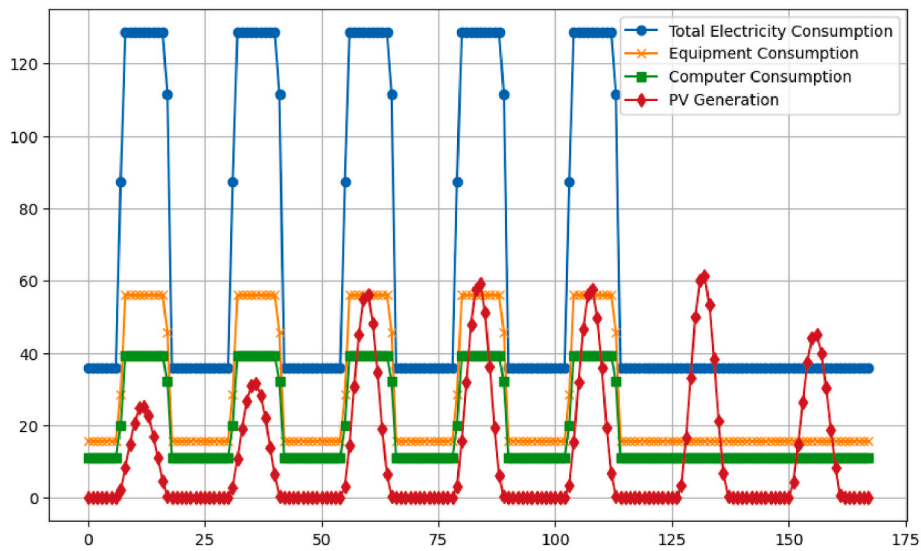

Fig. 6. Electricity production and consumption in a typical winter week.

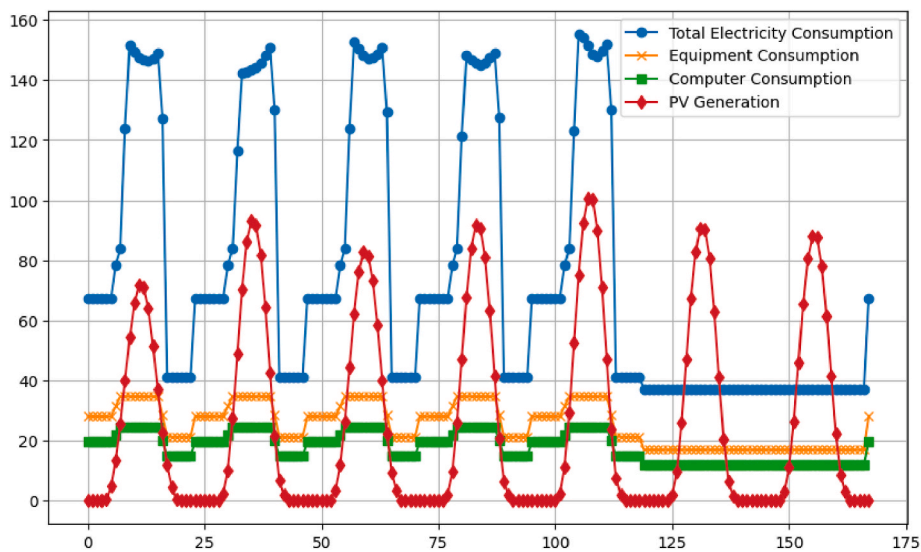

Fig. 7. Electricity production and consumption in a typical summer week.

Table 6
Energy indexes.

Index	Configuration 1	Configuration 2	Difference	Unit
C	478.65	472.55	6.10	MWh
P	135.49	129.39	6.10	MWh
I	344.84	339.24	5.60	MWh
E	23.12	23.61	-0.50	MWh
LCF	24.07 %	24.24 %	-0.17 %	-

3.2. Life cycle impact assessment and interpretation

The life cycle energy and environmental impacts are calculated referring to the functional unit for the two PSUs. Table 6 shows the impacts of the manufacturing stage (from cradle to gate). The GER for AC PSU is 303 MJ while for the DC PSU is 191 MJ, with a percentage reduction of about 37 % in the second case. For both the examined scenarios about 92 % of energy is produced by non-renewable energy sources. The DC PSU also performs better than its AC counterpart in all the environmental impact categories, with a reduction between 15 %

and 45 % (Fig. 8). The categories in which the reduction is higher than 40 % are IR and WU, while the categories with an impact reduction lower than 20 % are HTc, and HTnc.

A contribution analysis is developed, to identify the PSUs components responsible of the higher impacts. In detail, the component responsible for the 82 % of impact GER in the base case is the PWB for the base scenario (Fig. 9); PWB also causes the highest environmental impact between all sub-components. It reaches an incidence in all categories between a minimum of 39 % in HTc and a maximum of 99.98 % in WU, with an average value of 76 %. The only exception is for the HTc category, in which the larger impact is caused by steel (about 43 %).

The above results highlight that reducing PWB sub-components can improve the energy and environmental performances of the examined devices.

Similar results can be obtained for the DC PSU (Fig. 10). Also in this case, PWB is the component characterised by the highest impact for almost all categories, with the only exception for Human toxicity cancer such as the base case.

A contribution analysis for PWB is carried out, respectively, in Fig. 11 for AC and in Fig. 12 for DC scenario, in order to find the main

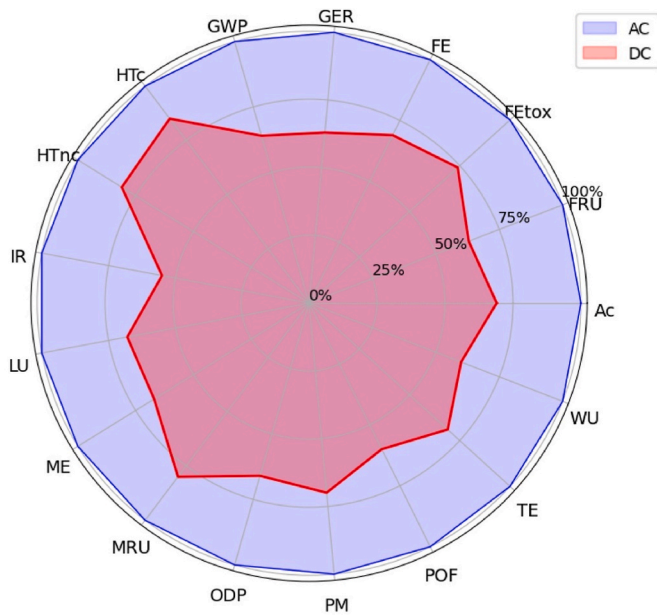

Fig. 8. Percentage difference of the impacts for the two examined PSUs.

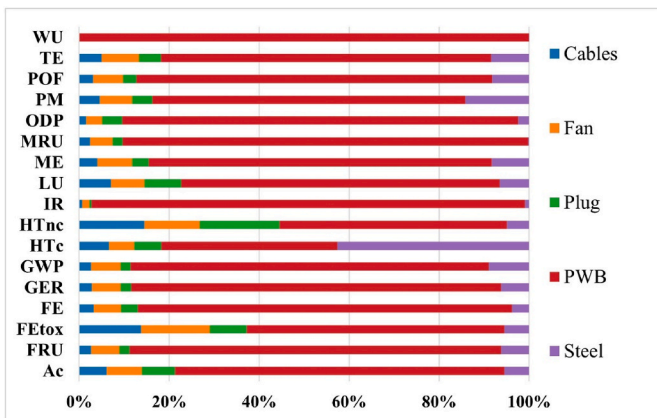

Fig. 9. Contribution analysis of AC PSU.

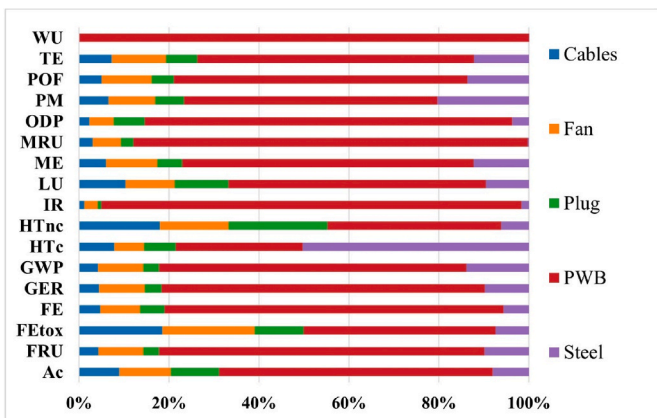

Fig. 10. Contribution analysis of DC PSU.

sub-components that cause the higher impact.

In the base case, capacitors and inductors are the component with the highest impact for almost all categories. Capacitors incidence ranges

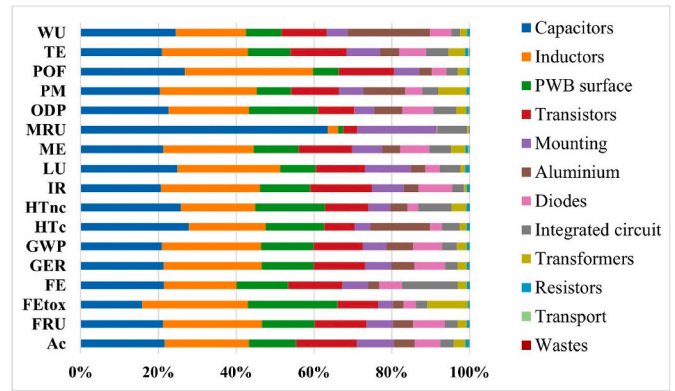

Fig. 11. Contribution analysis of AC PWB.

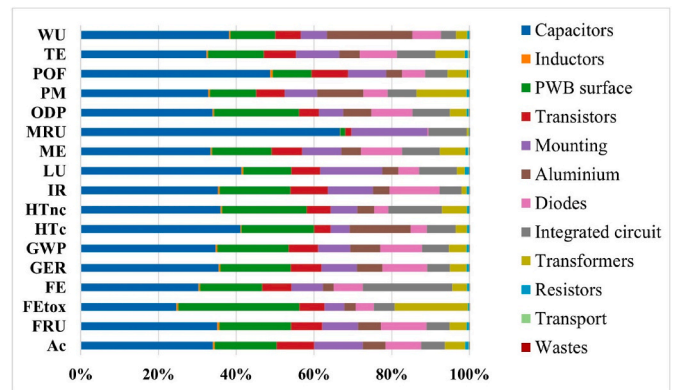

Fig. 12. Contribution analysis of DC PWB.

from 16 % (FEtox) to 64 % (MRU) with an average value of 25 % in all impact categories, while inductors percentage vary from 2 % (MRU) to 33 % (POF) with an average of 22 %. PWB surface, transistors and mounting have an average value of impact of 10 % in all categories; aluminium, diodes, integrated circuit, and transformers incidence varies from 2 % to 5 % and then resistors, transport and wastes cause a negligible impact (less than 1 %). In DC PWB in which some inductors are removed, these components cause a negligible impact, less than 1 %, capacitors incidence oscillates between 25 % (FEtox) to 67 % (MRU) with an average value of 37 %, increasing the influence of this component with respect to the case base. PWB surface increases its percentage incidence on the total impacts of about 16 % (6 % more than the base case), while for the other components the situation remains almost unchanged.

The results for the use phase of the two PSU are shown in Tables 8 and 9, respectively for the two scenarios of electricity production.

In the first scenario (Table 7), for each impact category, a reduction of 4.5 % is observed, as expected according to the reduced energy consumption. Although this reduction may appear modest, it is important to consider that in an office setting, for example, there may be hundreds of units and the benefit of using DC PSU is amplified. Furthermore, if other loads operating in DC are used in the office, the environmental benefits would be further amplified.

Table 8 shows the comparison between the AC PSU using the Italian electricity mix and the DC PSU using low voltage electricity produced by a 3 kW PV plant (single-Si) (Scenario 2). The results show that for almost all impact categories the AC PSU cause the highest impact except for MRU. The reduction impact for the DC PSU compared to the AC PSU is between 22 % and 85 % except for MRU in which the DC PSU overcome its counterpart of about 10 %. In conclusion, the use of directly DC electricity from PV panel can significantly reduce the environmental

Table 7
Life-cycle energy and environmental impacts of PSUs.

Impact category	AC PSU	DC PSU	Reduction
Ac	1.20E-01	8.20E-02	31.5 %
FRU	2.65E+02	1.66E+02	37.2 %
FE _{tox}	1.40E+02	1.04E+02	25.6 %
FE	1.79E-02	1.23E-02	31.5 %
GER	3.03E+02	1.91E+02	36.8 %
GWP	1.66E+01	1.06E+01	35.7 %
HTc	2.44E-08	2.07E-08	15.4 %
HTnc	5.69E-07	4.58E-07	19.4 %
IR	7.01E+00	3.89E+00	44.6 %
LU	7.33E+01	5.01E+01	31.7 %
ME	1.80E-02	1.21E-02	32.7 %
MRU	4.63E-03	3.70E-03	20.2 %
ODP	1.04E-06	6.80E-07	34.4 %
PM	8.56E-07	5.95E-07	30.5 %
POF	8.51E-02	5.14E-02	39.6 %
TE	1.81E-01	1.25E-01	31.1 %
WU	4.51E+03	2.69E+03	40.3 %

Table 8
Use phase Scenario 1.

Impact category	AC PSU	DC PSU
Ac	9.43E+00	9.01E+00
FRU	3.42E+04	3.27E+04
FE _{tox}	6.42E+03	6.12E+03
FE	4.75E-01	4.53E-01
GER	4.84E+04	4.62E+04
GWP	2.38E+03	2.28E+03
HTc	9.30E-07	8.88E-07
HTnc	3.19E-05	3.05E-05
IR	2.81E+02	2.68E+02
LU	1.08E+04	1.03E+04
ME	1.45E+00	1.38E+00
MRU	2.53E-02	2.41E-02
ODP	5.22E-05	4.98E-05
PM	4.68E-05	4.47E-05
POF	6.90E+00	6.58E+00
TE	1.65E+01	1.58E+01
WU	1.40E+03	1.34E+03

Table 9
Use phase Scenario 2.

Impact category	AC PSU	DC PSU	Reduction
Ac	9.43E+00	3.46E+00	63.3 %
FRU	3.42E+04	5.76E+03	83.2 %
FE _{tox}	6.42E+03	4.38E+03	31.8 %
FE	4.75E-01	2.84E-01	40.3 %
GER	4.84E+04	2.84E+04	41.2 %
GWP	2.38E+03	4.62E+02	80.6 %
HTc	9.30E-07	5.54E-07	40.4 %
HTnc	3.19E-05	2.49E-05	22.1 %
IR	2.81E+02	4.17E+01	85.1 %
LU	1.08E+04	1.80E+03	83.3 %
ME	1.45E+00	5.30E-01	63.4 %
MRU	2.53E-02	2.79E-02	-10.4 %
ODP	5.22E-05	2.90E-05	44.4 %
PM	4.68E-05	3.14E-05	32.8 %
POF	6.90E+00	1.97E+00	71.5 %
TE	1.65E+01	5.54E+00	66.5 %
WU	1.40E+03	3.33E+02	76.3 %

impact compared to the Italian electricity mix.

Table 10 reports the total impacts of the two PSUs, considering both the manufacturing and the operation stage for all scenarios. For Scenario 1, the impacts of DC PSU decrease of about 5 % compared to these of the AC PSU for almost all the examined categories, except for MRU and WU for which the reduction is about 7 % and 32 %, respectively. For Scenario 2, the reduction is much higher for almost all impact categories

Table 10
Total life-cycle energy and environmental impacts of PSUs “from cradle to use”.

Impact category	AC PSU	DC PSU (Scenario 1)	Reduction (Scenario 1)	DC PSU (Scenario 2)	Reduction (Scenario 2)
Ac	9.55E+00	9.09E+00	4.9 %	3.54E+00	62.9 %
FRU	3.45E+04	3.28E+04	4.8 %	5.92E+03	82.8 %
FE _{tox}	6.56E+03	6.23E+03	5.0 %	4.48E+03	31.7 %
FE	4.92E-01	4.65E-01	5.5 %	2.96E-01	39.9 %
GER	4.87E+04	4.64E+04	4.7 %	2.86E+04	41.2 %
GWP	2.40E+03	2.29E+03	4.8 %	4.73E+02	80.3 %
HTc	9.55E-07	9.09E-07	4.8 %	5.75E-07	39.8 %
HTnc	3.25E-05	3.09E-05	4.8 %	2.53E-05	22.0 %
IR	2.88E+02	2.72E+02	5.5 %	4.56E+01	84.1 %
LU	1.09E+04	1.04E+04	4.7 %	1.86E+03	83.0 %
ME	1.46E+00	1.39E+00	4.9 %	5.42E-01	63.0 %
MRU	2.99E-02	2.78E-02	7.0 %	3.16E-02	-5.7 %
ODP	5.32E-05	5.05E-05	5.1 %	2.97E-05	44.2 %
PM	4.76E-05	4.53E-05	5.0 %	3.20E-05	32.8 %
POF	6.98E+00	6.64E+00	5.0 %	2.02E+00	71.1 %
TE	1.67E+01	1.59E+01	4.8 %	5.67E+00	66.1 %
WU	5.91E+03	4.03E+03	31.8 %	3.02E+03	48.9 %

(from 22 % to 84 %). A higher environmental impact (around 6 %) is observed for MRU.

Contribution analyses are performed to compare the impact between the manufacturing and the use phase as shown in Fig. 13.

It can be observed that the use phase is the main hot spot for almost all categories (impacts ranging from around 84 %–99 %) except for WU, in which the manufacturing stage is characterised by an incidence of 76 % for AC PSU, 67 % and 89 % for DC PSU in the Scenario 1 and 2, respectively.

The use phase is the predominant contributor to the environmental impact across all scenarios and categories analysed in this study, excepting for WU, where the manufacturing stage shows a significant impact. These findings highlight the critical importance of the use phase for this device, with results that can be extended to other DC electric loads. Even a modest percentage reduction in energy consumption can be observed during the use stage when both the devices receive

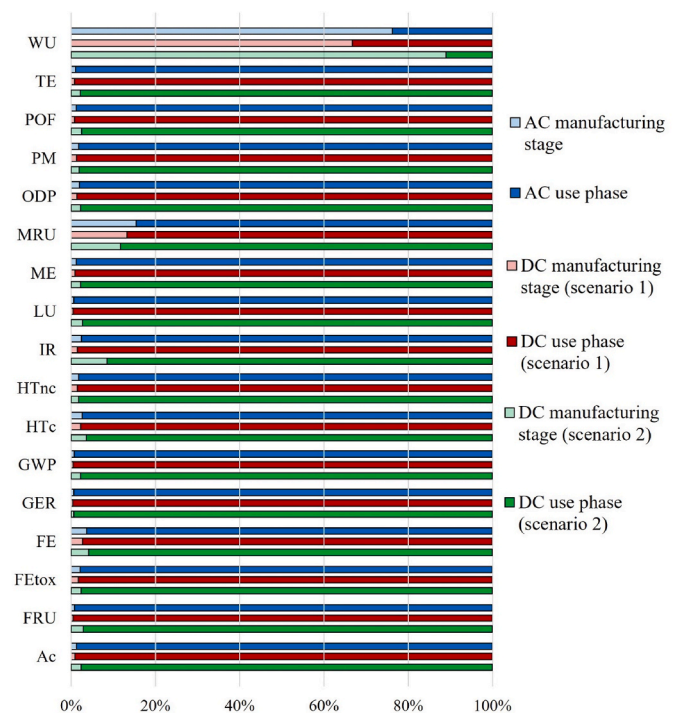

Fig. 13. Contribution analysis manufacturing vs use for AC and DC PSU (Scenario 1 and 2).

electricity from the grid, it can become significant if the calculation is applied to the multitude of devices operating in direct current. Thus, this strategy has the potential to achieve a substantial reduction in overall environmental impact, especially if the DC microgrid includes renewable energy technologies (e.g. PV).

4. Conclusions

The paper assessed the energy and environmental aspects of a PSU to demonstrate that directly DC loads can cause a lower impact than their AC counterpart. Firstly, an office building equipped with a PV system was analysed, using various energy performance indicators. The results showed that the adoption of a direct DC power distribution system results in modest, but measurable energy savings for office buildings. Additionally, this configuration reduces grid dependency and improves self-consumption of PV energy, highlighting its advantages. Manufacturing analysis of the PSU identified the PWB as the primary contributor to environmental impact across all categories. So, reducing PWB sub-components was shown to enhance the overall energy and environmental performance of the PSU. Contribution analysis of the two PWBs indicated that, in the baseline scenario, capacitors and inductors were the highest-impact components. However, in the second scenario, the removal of certain inductors shifted the burden, making capacitors and the PWB surface the most impactful components. The life cycle analysis revealed that the DC PSU performed better than the AC PSU across all considered impact categories except for MRU in scenario 2. In Scenario 1, impact reductions ranged from 5 % (across all categories except MRU and WU) to 32 % (WU). In Scenario 2 the reductions were even more significant, ranging from 22 % to 88 % with the exception of MRU where the AC PSU performed better.

To further evaluate the energy benefits of using a direct DC PSU, a comparison of the manufacturing and use phases revealed that, through all scenarios and impact categories, except water use, the use phase had the greatest impact. These results suggest that transitioning to DC-powered systems could lead to significant cumulative environmental benefits, particularly in large-scale applications such as office buildings and industrial facilities. Expanding the implementation of DC systems across various devices could further reduce energy consumption and associated environmental impacts.

The results of the research can be the basis for further studies on different DC loads and building types or districts. The development of new datasets representing DC loads will enable more comprehensive assessments of the environmental benefits of DC microgrids.

CRedit authorship contribution statement

Sonia Longo: Writing – review & editing, Validation, Supervision, Resources, Project administration, Methodology, Funding acquisition, Conceptualization. **Alberto Affranchi:** Writing – original draft, Validation, Software, Investigation, Formal analysis, Data curation, Conceptualization. **Maurizio Cellura:** Writing – review & editing, Visualization, Validation, Supervision, Methodology, Conceptualization. **Francesco Guarino:** Writing – review & editing, Visualization, Software, Formal analysis, Data curation.

Declaration of competing interest

The authors declare that they have no known competing financial interests or personal relationships that could have appeared to influence the work reported in this paper.

Acknowledgement

The research is developed within the project LOV – Lowering Ortigia's Voltage, CUP G39J18000690007, funded with the D.D.G. n.1413/5S., September 26, 2022, within the Action 1.1.1 “Qualified investments

for the development and strengthening of research and innovation capacities” - Complementary Operational Programme (POC) 2014–2020 Interventions under the action 1.1.1 of POC Sicilia 2014_2020 – Completing list Action 1.1.5 PO FESR 2014/2020.

Data availability

Data will be made available on request.

References

- [1] Zhu X, Zhang X, Gong P, Li Y. A review of distributed energy system optimization for building decarbonization. *J Build Eng* 2023;73:106735. <https://doi.org/10.1016/j.jobte.2023.106735>.
- [2] Alharbi AG, Olabi AG, Rezk H, et al. Optimized energy management and control strategy of photovoltaic/PEM fuel cell/batteries/supercapacitors DC microgrid system. *Energy* 2024;290:130121. <https://doi.org/10.1016/j.energy.2023.130121>.
- [3] Shiva Kumar S, Himabindu V. Hydrogen production by PEM water electrolysis – a review. *Mater Sci Energy Technol* 2019;2:442–54. <https://doi.org/10.1016/j.mset.2019.03.002>.
- [4] Shaukat N, Islam MdR, Rahman MdM, et al. Decentralized, democratized, and decarbonized future electric power distribution grids: a survey on the paradigm shift from the conventional power system to micro grid structures. *IEEE Access* 2023;11:60957–87. <https://doi.org/10.1109/ACCESS.2023.3284031>.
- [5] Biegańska M. IoT-based decentralized energy systems. *Energies* 2022;15:7830. <https://doi.org/10.3390/en15217830>.
- [6] Nadeem TB, Siddiqui M, Khalid M, Asif M. Distributed energy systems: a review of classification, technologies, applications, and policies. *Energy Strategy Rev* 2023;48:101096. <https://doi.org/10.1016/j.esr.2023.101096>.
- [7] Ramos C, García AS, Moreno B, Díaz G. Small-scale renewable power technologies are an alternative to reach a sustainable economic growth: evidence from Spain. *Energy* 2019;167:13–25. <https://doi.org/10.1016/j.energy.2018.10.118>.
- [8] Shi Y, Zhao Q, Jiao L. Optimum exploitation of multiple energy system using IGDT approach and risk aversion strategy and considering compressed air storage with solar energy. *Energy* 2024;291:130369. <https://doi.org/10.1016/j.energy.2024.130369>.
- [9] Antonanzas-Torres F, Antonanzas J, Blanco-Fernandez J. Environmental life cycle impact of off-grid rural electrification with mini grids in West Africa. *Sustain Energy Technol Assess* 2021;47:101471. <https://doi.org/10.1016/j.seta.2021.101471>.
- [10] Lee J. Environmental hotspot assessment for a PV mini-grid design: a case study for Malawi. *Energies* 2021;14:4227. <https://doi.org/10.3390/en14144227>.
- [11] Stinder AK, Finke S, Vendeleric M, Severengiz S. A generic GHG-LCA model of a smart mini grid for decision making using the example of the Don Bosco mini grid in Tema, Ghana. *Procedia CIRP* 2022;105:776–81. <https://doi.org/10.1016/j.procir.2022.02.129>.
- [12] Tooryan F, HassanzadehFard H, Collins ER, et al. Smart integration of renewable energy resources, electrical, and thermal energy storage in microgrid applications. *Energy* 2020;212:118716. <https://doi.org/10.1016/j.energy.2020.118716>.
- [13] Shen Y, Zhai J, Kang Z, et al. Distributionally robust chance-constrained energy management for island DC microgrid with offshore wind power hydrogen production. *Energy* 2025;316:134570. <https://doi.org/10.1016/j.energy.2025.134570>.
- [14] Elkadeem MR, Kotb KM, Abido MA, et al. Techno-enviro-socio-economic design and finite set model predictive current control of a grid-connected large-scale hybrid solar/wind energy system: a case study of Sokhna Industrial Zone, Egypt. *Energy* 2024;289:129816. <https://doi.org/10.1016/j.energy.2023.129816>.
- [15] Yao Z, Ran L, Wang Z, Guo X. Integrated management of electric vehicle sharing system operations and Internet of Vehicles energy scheduling. *Energy* 2024;309:132498. <https://doi.org/10.1016/j.energy.2024.132498>.
- [16] Garau M, Torsæter BN. A methodology for optimal placement of energy hubs with electric vehicle charging stations and renewable generation. *Energy* 2024;304:132068. <https://doi.org/10.1016/j.energy.2024.132068>.
- [17] Rezaei N, Khazali A, Mazidi M, Ahmadi A. Economic energy and reserve management of renewable-based microgrids in the presence of electric vehicle aggregators: a robust optimization approach. *Energy* 2020;201:117629. <https://doi.org/10.1016/j.energy.2020.117629>.
- [18] Iweh CD, Gyamfi S, Tanyi E, Effah-Donyina E. Distributed generation and renewable energy integration into the grid: Prerequisites, push factors, practical options, issues and merits. *Energies* 2021;14:5375. <https://doi.org/10.3390/en14175375>.
- [19] Sarangi S, Sahu BK, Rout PK. Distributed generation hybrid AC/DC microgrid protection: a critical review on issues, strategies, and future directions. *Int J Energy Res* 2020;44:3347–64. <https://doi.org/10.1002/er.5128>.
- [20] Kumar D, Zare F, Ghosh A. DC microgrid technology: system architectures, AC grid interfaces, grounding schemes, power quality, communication networks, applications, and standardizations aspects. *IEEE Access* 2017;5:12230–56. <https://doi.org/10.1109/ACCESS.2017.2705914>.
- [21] Faraji H, Nosratabadi SM, Hemmati R. AC unbalanced and DC load management in multi-bus residential microgrid integrated with hybrid capacity resources. *Energy* 2022;252:124070. <https://doi.org/10.1016/j.energy.2022.124070>.

- [22] Ghiassi M. Detailed study, multi-objective optimization, and design of an AC-DC smart microgrid with hybrid renewable energy resources. *Energy* 2019;169: 496–507. <https://doi.org/10.1016/j.energy.2018.12.083>.
- [23] Al-Ismail FS. DC microgrid planning, operation, and control: a comprehensive review. *IEEE Access* 2021;9:36154–72. <https://doi.org/10.1109/ACCESS.2021.3062840>.
- [24] Stippich A, Sewergin A, Engelmann G, et al. From AC to DC: demonstration of benefits in household appliances. *International ETG Congress 2017*. 2017. November 28–29, 2017, Bonn, Germany.
- [25] Gerber DL, Musavi F, Ghatpande OA, et al. A comprehensive loss model and comparison of AC and DC boost converters. *Energies* 2021;14:3131. <https://doi.org/10.3390/en14113131>.
- [26] Nagaraj C. Reduction of power conversion losses in AC-DC coupled hybrid microgrid under grid distorted voltage scenario. *Electr Power Syst Res* 2022;210:108101. <https://doi.org/10.1016/j.epsr.2022.108101>.
- [27] Eskander MM, Silva CA. Techno-economic and environmental comparative analysis for DC microgrids in households: Portuguese and French household case study. *Appl Energy* 2023;349:121495. <https://doi.org/10.1016/j.apenergy.2023.121495>.
- [28] Kockel C, Nolting L, Goldbeck R, et al. A scalable life cycle assessment of alternating and direct current microgrids in office buildings. *Appl Energy* 2022; 305:117878. <https://doi.org/10.1016/j.apenergy.2021.117878>.
- [29] Longo S, Cellura M, Cusenza MA, et al. Life cycle assessment for supporting eco-design: the case study of sodium–nickel chloride cells. *Energies* 2021;14:1897. <https://doi.org/10.3390/en14071897>.
- [30] Sala S, Amadei AM, Beylot A, Ardente F. The evolution of life cycle assessment in European policies over three decades. *Int J Life Cycle Assess* 2021;26:2295–314. <https://doi.org/10.1007/s11367-021-01893-2>.
- [31] ISO 14040. *Environmental management: life cycle assessment; Principles and framework*. 2021.
- [32] ISO 14044. *Environmental management: life cycle assessment; Requirements and Guidelines*. 2021.
- [33] European Commission. Joint Research Centre. Institute for Environment and Sustainability. *International Reference Life Cycle Data System (ILCD) Handbook : general guide for life cycle assessment : detailed guidance*. Office, LU: Publications; 2010.
- [34] Köck B, Friedl A, Serna Loaiza S, et al. Automation of life cycle assessment—a critical review of developments in the field of life cycle inventory analysis. *Sustainability* 2023;15:5531. <https://doi.org/10.3390/su15065531>.
- [35] Simapro 9.6 PRé sustainability. <https://simapro.com/>; 2024.
- [36] Wernet G, Bauer C, Steubing B, et al. The ecoinvent database version 3 (part I): overview and methodology. *Int J Life Cycle Assess* 2016;21:1218–30. <https://doi.org/10.1007/s11367-016-1087-8>.
- [37] Althaus H-J, Hischier R, Doka G, et al. *Implementation of life cycle impact assessment methods Data v20*. 2007. 2007) Ecoinvent report No 3. Switzerland.
- [38] European Commission – Joint Research Centre. *EN 15804 reference package based on EF 3.1 reference package*. 2023.