

# Grid-forming converters. A review of pilot projects and control structures

Rossano Musca<sup>a</sup>, Antony Vasile<sup>a,\*</sup>, Gaetano Zizzo<sup>a</sup>

<sup>a</sup>Engineering Department, University of Palermo

---

## Abstract

5 Grid-forming control can be a useful solution for all dynamic issues in weak grids and for providing ancillary services. It represents the new frontier in modern power electronics, responding to the needs of power systems more and more rich in renewables and, for this reason, with lower inertia. Today, the research on grid-forming is mainly oriented to propose new and more effective control schemes and to evaluate their performances with simulation tools, but few works in the literature focus on the results of on-field experimentation. Therefore, this paper aims to provide a  
10 comprehensive review of grid-forming pilot projects and demonstrators developed worldwide. The work describes the main pilots providing an accurate analysis of the technical features of each demonstrator, and it proposes a critical discussion on the motivations that have driven each installation and on the results which have been obtained or are expected. The demonstrators are finally compared remarking their analogies and differences, trying to chart the development trajectory of this new technology.

15 *Keywords:* control structures, grid-forming, pilot projects, power converters.

*2010 MSC:* 00-01, 99-00

---

## 1. Introduction

The energy transition in progress and the consequent reduction of energy supply from fossil fuels is causing the divestment of traditional rotating generators in favour of energy sources that are interfaced to the electrical grid through power electronic converters. While this transformation leads to a reduction in  $CO_2$  emissions, on the other hand, technical issues related to the operation of the electric power system are rising, due, in particular, to the reduction of the overall system inertia and primary reserve and to the aleatory nature of renewables that increase the risk of instability [1], [2]. Therefore, power converters must provide new services to maintain adequate level of security and service quality even in renewables dominated energy systems [3].

Conventional commercial converters incorporate a current control that does not allow the participation in regulation services, except in some particular cases [4], [5]. For this reason, the new concept of grid-forming (GFM) control was developed, to allow power electronic converters to support voltage and frequency and improve angle stability in the grid. The interest in this type of control has grown significantly in recent years, both in terms of academic research and investigation of new applications and in terms of development of industrial solutions and pilot projects. As an example, in [6] the authors discuss the applicability of grid-forming schemes to HVDC converters, while in [7], an interesting study is reported aiming at investigating the frequency stability of the Irish system when using GFM converters for a total replacement of synchronous generators. A similar analysis is presented in [8] on the IEEE 39-bus test network. In [9], the authors propose a bidirectional grid-forming converter with a fault-tolerant functionality applied to islanded AC microgrids using a centralized control architecture. Some experimental results are proposed. These works represent only a very small part of the vast literature on the subject. In general, it can be stated that most of the studies in the literature provide control methods for GFM converters and example of theoretical applications of those controls. In this framework, the contribution of this work is to present a comprehensive review of the GFM demonstrators installed worldwide, outlining the main technical features of each demonstrator and discussing the

---

\*Corresponding author at: University of Palermo  
Email address: antony.vasile@unipa.it (Antony Vasile)

motivations that have driven each installation and the results obtained or expected.

The paper contains finally an analysis of the experimental experiences on grid-forming in the form of Q&A, which is intended to guide the reader toward a deeper understanding of GFM converter experimentation through pilot projects, and stimulate interest in this research subject.

## 2. Methodology

The review has been done according to Glasziou's approach [10], comprising the four following steps:

- Formulation of researchable questions;
- Disclosure of studies;
- Evaluation of their quality;
- Synthesis.

The main questions the present review aims to answer are two:

1. identifying the main GFM pilot projects and demonstrators;
2. discussing the integration of GFM demonstrators in the power system, by examining the results of the pilot installations.

The main database used for finding relevant studies on the topic was Scopus, searching for specific keywords. The first keyword was "Grid-Forming demonstrator". Given the scarcity of results (only 7 papers), the second keyword used was "Grid-Forming". The last search was conducted in September 2021 and 4,723 papers were found. Those papers included different case study reports, control strategies analysis, technical issues, methodology papers, mathematical models, review papers, etc. Selecting the subject area "Energy", the list was limited to 902 articles. After an initial screening to exclude papers not directly related to pilots and demonstrators, approximately 100 papers remained, which are categorized as follows:

- technical data and purposes of demonstrators;
- control techniques implemented and services provided by the demonstrators.

Finally, some of the 100 papers were discarded because they did not contain new information with respect to other more complete papers in the list. In addition to the search on Scopus, reports and technical documents dealing with implementation experiences were found using the Google search engine. In conclusion, the analysis of the literature shows that there is a research gap on GFM demonstrators, as there is not a single document reporting a comprehensive and critical review of this topic. All documents were analyzed covering, in particular, the following aspects:

- a. Pilot projects and demonstrators in the world;
- b. Demonstrators data and applications;
- c. Specific control strategies applied;
- d. Results obtained from the experimentation.

Therefore, the present review is structured as follows: Section 3 discusses the concept of grid forming control, the way it was originally conceived and the goals it aims to fulfil in relation to the other control philosophy represented by grid-following converters, while Section 4 describes in detail the status of demonstrators and pilot projects, reporting their main technical data, their different purposes, the services they provide and the results obtained during the experimentation. Starting from the content of previous sections and from the experience of the authors on power systems studies, Section 5 provides a discussion on GFM demonstrators in the form of Q&A. Finally, Section 6 contains the conclusions of the work.

### 3. Grid-forming concept

The term "grid-forming" makes its first appearance in 2001 [11], but the first paper proposing the use of inverters to support the grid during power imbalances and frequency deviations dates back to 2008 with the introduction of the Virtual Synchronous Machine (VSM) concept [12]. At that time, however, there was not exactly talk of "grid-forming". Even today the concept of GFM inverter has not been clearly defined and it is being studied by the scientific community [13]. In fact, neither the International Electrotechnical Vocabulary (IEV) nor IEEE standards contain a definition of the term "grid-forming". According to the European Network of Transmission System Operators for Electricity (ENTSO-E) [14], grid-forming capabilities need to be defined in Connection Network Codes (CNCs) to enable harmonised solutions, while the National Renewable Energy Laboratory (NREL) defines grid-forming controllers as any inverter controller that regulates instantaneous terminal voltages without a Phase Locked Loop (PLL) and that can coexist with other grid-following and grid-forming inverters and synchronous generation on the same system [15].

Basically, a GFM inverter is a converter that allows to directly control the voltage at its terminals independently of the grid voltage. This feature distinguishes GFM from classical grid-following (GFL) converters, in which the directly controlled output is the current delivered. From a conceptual point of view, therefore, a GFM converter can be represented, in its simplest version, as a voltage source with a low series impedance, while a GFL converter is represented, in a dual way, as a current source with a high parallel impedance, Figure 1.

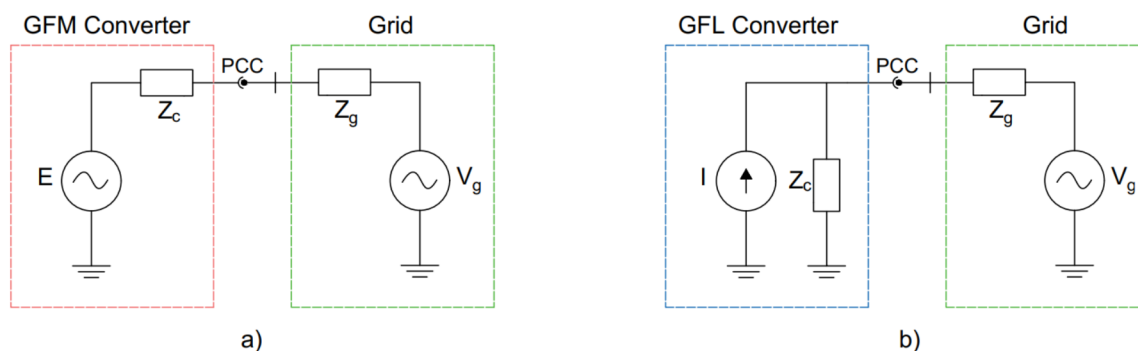

Figure 1: Basic representation of a GFM converter (a) and of a GFL converter (b)

GFM converters can provide a voltage signal even in the absence of load or grid voltage, which is impossible for GFL converters that instead require the presence of a network signal for synchronization and current injection. It is precisely this feature that stimulates researches in the concept of grid-forming: the possibility of maintaining a constant voltage signal even in the presence of network imbalances is of particular interest for system operators [16], [17].

The concept of grid-forming has been originally introduced for smart grids and autonomous power systems applications [18], [19], [20], [21], [22]. However, grid-forming converters are also considered as an interesting solution to support the stable operation of large, interconnected power systems with high penetration of non-synchronous generation interfaced through power electronics [23], [24]. While this behaviour can be supportive of the network, the imposition of the voltage phasor can lead to sudden increases in current that, in extreme cases, can damage the component itself. This does not happen in GFL converters as the current phasor amplitude is directly controlled and cannot exceed the set thresholds. In any case, several studies show the adequacy of GFM converters in operating in weak networks dominated by inverter-based generation [25], [26], while other studies highlight the limits of this technology in robust networks, where performances are lower than its GFL counterpart [27], [28].

Over the past years, many different grid-forming control structures have been proposed and analyzed [18], [19], [29]. The different grid-forming controls can be possibly classified in the following groups: droop methods [21], [30], [31], power synchronization control [32], [33], synchronverter [34], [35], virtual synchronous machines (VSM) [36], [37], [38], [39], matching control [40], direct power control [41] [42] and others [43] [44] [45]. The droop control

is the simplest grid-forming implementation, where the internal frequency is determined multiplying the difference between the active power reference and the measured active power by a gain, and then obtaining the converter angle integrating the synthesized frequency signal. The power synchronization control is a grid-forming method similar to droop controls, where the converter angle variation is determined by integrating the difference between the reference and the measured active power multiplied by a gain, and then the converter angle is obtained by adding the integral of a reference frequency to the angle variation determined by the power-angle control. Synchronverter and VSM are grid-forming schemes which realize the grid-forming capabilities by a direct emulation of the characteristics of synchronous machines, simply replicating the intrinsic behaviour defined by the swing equation or implementing more complex control schemes to include the replication of the machine electrical dynamics. In the matching control, the converter pulse-width-modulation signal is controlled in order to achieve exact matching between the converter in closed-loop and the synchronous machine dynamics, while direct power control technique is based on p-q theory and instantaneous power errors of active and reactive power components are kept within a fixed hysteresis band to provide reference values of powers.

The possible grid-forming controls are based on different implementations and realizations of specific functionalities, but they all share the common principle of forming the output voltage by controlling its magnitude and angle.

#### 4. Pilot projects and demonstrators

This section presents the various pilot projects. A total of 14 projects have been identified as the most significant worldwide and they are reported below in chronological order from least to most recent.

##### 4.1. Zurich BESS, Switzerland

One of the first demonstrators with grid-forming capabilities was the Zurich Battery Energy Storage System (BESS). The unit, commissioned in 2012, operated by Elektrizitätswerke des Kantons Zürich (EKZ), the Utility of the Canton of Zürich, and operative since 2014, was designed in order to participate to the new ancillary services market for Primary Control Reserve (PCR) started in 2015 by the Transmission System Operators (TSOs) of Germany, Austria, the Netherlands and Switzerland. The demonstrator has three different applications: primary frequency control, peak shaving and islanded operations. Since its qualification, the unit participated in the Swiss market and in the new PCR market winning tenders for 41 weekly bid periods as of 31/12/2015 [46].

The system has a rated power of 1 MW overloadable until 1.3 MW for 15 minutes. The storage has a capacity of 580 kWh but it can deliver only 250 kWh at full power in order to prevent an early deterioration of the batteries cells. To allow different grid application tests, the system was designed for both low voltage (LV) and medium voltage (MV) connections. In addition, thanks to seven independent switches, different configurations are allowed to test typical MV grid situations. Figure 2 shows the single line diagram of the system [47]:

- the blue line represents the low voltage connection of loads and generators;
- the yellow line represents the direct connection with the MV grid;
- the red line represents the connection of loads and generators during the island-mode operation of the system allowed by the grid-forming capabilities of the converters.

The different configurations are controlled via OPC (OLE for Process Control) by a SCADA system that integrates the switches and all measurements and alarms of all the components.

The performances of the Power Conversion System (PCS) depend on the converter mode that, for this demonstrator, can be both Voltage Source Inverter (VSI) and Current Source Inverter (CSI) mode. The VSI mode improves local power quality, is indicated for smaller grids and almost indispensable for microgrids. On the other hand, the PCS is subjected to higher current magnitude fluctuations, leading to an efficiency degradation. In CSI mode, the regulation occurs through a current injection in a faster and more efficient way. However, in this configuration, it is impossible to run the islanded mode. The project demonstrates that CSI and VSI modes can coexist in the same devices, switching one from the other according to the specific needs.

Major challenges occurred especially in the control algorithm and in the estimation of the batteries' State-of-Charge (SoC) value. From the point of view of the battery degradation, no important sign of decay due to normal operation

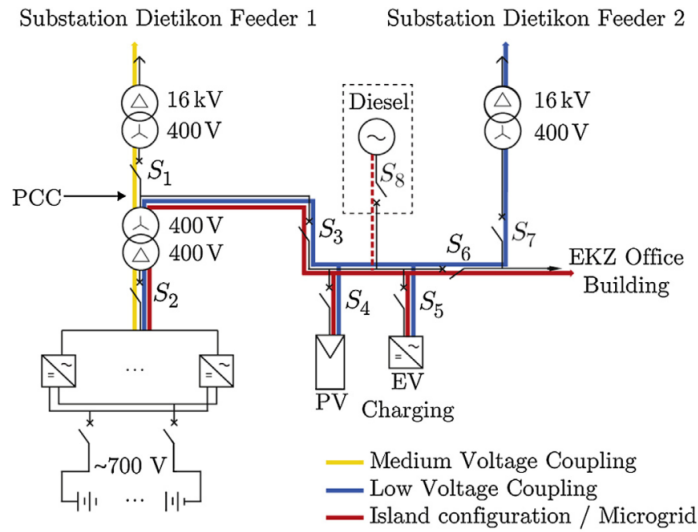

Figure 2: Single line diagram of the Zurich demonstrator [47]

has been noticed.

#### 4.2. AusNet GESS, Australia

AusNet Services is the largest energy delivery company in the State of Victoria, Australia. In 2012, the company started a project for a Grid Energy Storage System (GESS) for managing the distribution network. The management of the project has been entrusted to a consortium led by ABB Australia [48] to design the GESS. The GESS was divided into three main components:

- a 1 MW/1 MWh Lithium-ion battery system coupled to the main grid through a 1.37 MVA inverter with grid-forming capabilities;
- a 1 MVA backup diesel generator;
- a substation for the connection with the main grid with a 3 MVA 22/0.415 kV/kV transformer.

The system was installed in Thomastown in 2014 and in 2015 the trial phase started with several tests for grid support services such as peak shaving, power factor correction, voltage support, phase load balance and islanded operations. Results have been released with the AusNet annual report 2016 [49] and 2017 [50]. The main outcome was achieved on the islanding operation: on February 2nd, 2016, a network fault resulted in an outage of the feeder to which GESS was connected. Being the fault upstream the GESS, it was possible to initiate a recovery procedure to start the islanded mode of the unit, enabling the supply of 104 commercial and industrial customers for almost 2 hours.

#### 4.3. Mackinac HVDC Voltage Source Converter, USA

The Mackinac back-to-back Voltage Source Converter HVDC was commissioned in 2012 by the American Transmission Company (ATC) for the power flow control between Michigan's Upper and Lower Peninsula [51]. The project was required to operate under weak system condition and mitigate other issues in the area, such as voltage oscillations and faults. Among all the control technologies available for the purpose, VSC HVDC was chosen over classical technologies due to its characteristics: independent active and reactive power control, black start capability, and static synchronous compensator (STATCOM) mode operation. These characteristics are realized by implementing a grid-forming control for the converters of the HVDC stations. The used converter design was the cascade two level (Figure 3). The equipment was designed for 200 MW and 100 MVar bidirectional power transfer at each terminal. The station

was energized with a pre-existing 138 kV AC line and in July 2014 began commercial operation. After an initial phase of testing, several studies were conducted to evaluate the response to adverse events such as short circuits, transferred power deviations, remote faults, and communication issues [52]. Despite some issues related to the production of interharmonics and interference caused by external high-frequency signals, the system made it possible to electrically connect Michigan's two peninsulas more economically than other feasible solutions, while also improving reliability and flexibility.

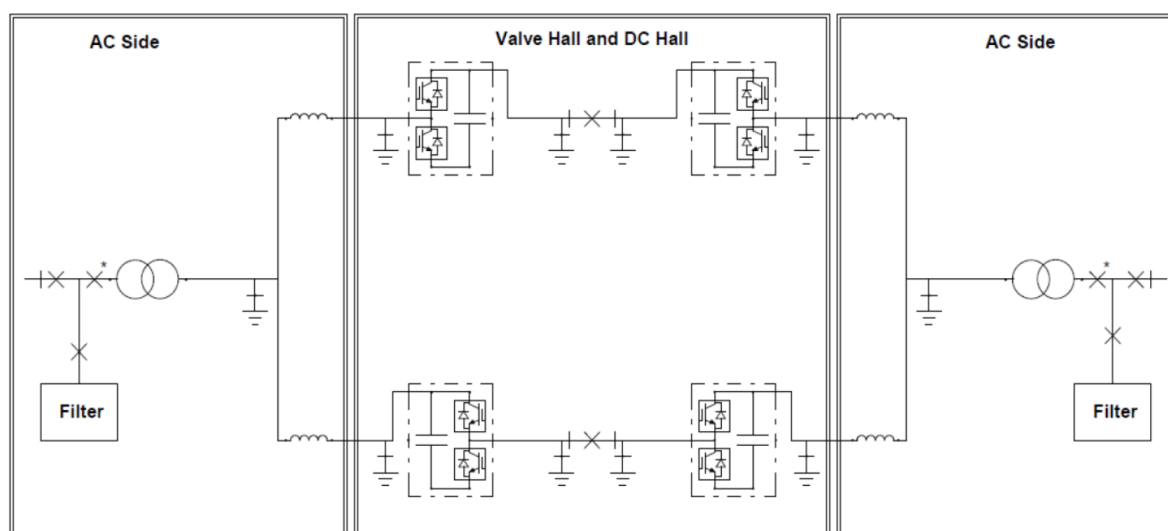

Figure 3: Simplified One-Line Diagram of Mackinac HVDC Converter Station [52]

#### 4.4. SMA projects - St. Eustatius, Saba, Portugal, French Polynesia, Germany

As a leading global company in solar systems technology, SMA has demonstrates great interest in grid-forming converters for large scale application carrying out various projects all over the world with different size and targets [53]. The experimentation started in 2017 with the St. Eustatius II Project, conducted in the homonym island of the Caribbean Sea. The energy mix installed in the island consists of 4 MVA of diesel generation, 4.15 MW of PV power and 5.9 MWh of BESS capacity, for an overall load of 2 MW. Batteries are connected to the grid via 2 hybrid GFM converters of 2.2 MW and one hybrid GFM converter of 1 MW, while the PV is connected via two inverter of 1 MW and 74 inverters of 25 kW. The solution allows a 100 % solar power feeding for 10.5 hours in diesel-off mode without compromising the reliability of the system. In the first year, the total energy provided was around 6.4 GWh with a diesel saving of 1.7 million liters. Even from the stability point of view, the system responded well: in the first six months, 7 events genset failures were compensated by the battery plant and an already installed synchronous condenser was decommissioned because of its high losses and low advantages. Another similar experience is conducted since 2019 on the island of Saba, in the Caribbean Sea too. The storage integration in the generation system was conducted in two phases: in phase one, an 800 kW/393 kWh storage system was designed and installed for the ramp rate control of a 1.142 MW PV plant. In phase two, both the storage capacity and the installed PV power were increased to 2.3 MWh and 2 MW<sub>p</sub>, respectively. Batteries are connected to the grid via 1 GFM converter of 2.2 MW while the PV plant is connected via 64 decentralized inverters of 25 kW. Even in this case, with a total load of about 1.2 MW, the system can provide up to 10 hours of 100 % renewable supply in diesel-off mode operation, with the saving of around one million liters of fossil fuel. Worth to mention are also the project Graciosa, Azores, Portugal, and the projects The Brando, Tetiaroa, French Polynesia, that highlight the interest in investigating small islands behaviour fed by 100 % renewable power sources.

Bordesholm is a small town of around 8000 inhabitants in the north of Germany. This city is the protagonist of a project that aim to demonstrate the strength of a lucrative business model based on primary regulation services [54]. SMA

was the technology provider, with a 15 MW/15 MWh storage system connected to the grid via 7 coordinated inverters of 2.5 MW. In late 2019, the public utility company Versorgungsbetriebe Bordesholm and TH Köln, University of Applied Sciences, simulated a large-scale power outage by disconnecting the town from the European main grid. The results were very successful, with anyone between households, businesses and institutions that even noticed the transition from the grid to the batteries supply, proving that a 100 percent renewable energy is feasible with the right technology.

#### 4.5. *Dersalloch Wind Farm, Scotland*

For approximately six weeks, from May to June 2019, a 69 MW wind farm in Dersalloch (Scotland) owned by Scottish Power Renewable (SPR) was operated in grid-forming mode [55]. Each of the 23 direct-drive full-converter 3 MW wind tower generators (WTG) was controlled for exploring inertia contributions of between  $H = 0.2$  s and  $H = 8$  s. During the test period, the response of the plant to various sensitive events coming from the electrical grid was verified in relation to the setting of the equipment: in particular, the single turbine inertia varied from 0.2 s to 8 s for a park average of between 0.2 s, 4 s and 7.5 s. Events recorded in the test phase include phase step response, interconnection tripping, and frequency events, natural or synthetic. During all recorded events, the park responded autonomously and immediately as expected, with power responses appropriate to the type of adverse event and in the absence of over-currents, over-voltages, or detachments. All this turns out to be true, however, in the presence of appropriate weather conditions, that is, in the persistence of a wind sufficient to guarantee the nominal power of the plant. Turbine's ability to respond may be effected if wind speed is declining during the response and the inertial response in case of low or zero power is extremely low. The trial continued at the same wind farm the following year from August to October 2020 [56]. In this case the aim of the experimentation was to verify the islanded mode and the black start capabilities of the turbines: the results showed that the park can operate in islanded mode with a minimum number of turbines in grid-forming mode, that re-synchronization with the grid is possible and that it is possible to perform a black start from a certain number of turbines, energizing the transmission grid up to the 132 kV/275 kV transformers.

#### 4.6. *Hornsedale Power Reserve, Australia*

Hornsedale Power Reserve (HPR) is a BESS plant installed near Jamestown, South Australia in 2017 and expanded in 2020. It consists lithium-ion batteries provided by Tesla for a total power capacity of 150 MW and an energy capacity of 194 MWh, and it is connected to the national transmission grid at 275 kV. Among the various inverters that allow the interface with the grid, two of them operate in VSM mode, allowing the provision of services such as fast frequency response and synthetic inertia. What makes this project particularly interesting is that it immediately entered the mechanisms of the Australian electricity market with positive impact both for grid support and market performance [57] [58]. Furthermore, the division of energy capacity for different purposes (70 MW grid services, 30 MW energy balances) allows the plant to participate in the System Integrity Protection Scheme (SIPS) but also to perform energy arbitrage and congestion management.

The validity of the system in responding to network disturbances was recently verified with a "real life test": on the night of May 25, 2021 there was an outage in a 405 MW turbine in a power plant that caused a domino effect involving several units and substations, and within minutes, approximately 500000 homes and businesses were without power [59]. The Hornsdale battery responded instantaneously to the frequency drift: in less than two seconds, the maximum available power (70 MW) was delivered at the minimum frequency peak (49.6 Hz) while, when the load was disconnected and the frequency returned to its nominal value, the plant's surplus supply of active power stopped. The response of the battery is reported in Figure 4 [60]. Hornsdale's experience confirms the importance of this new regulation frontier for the future electric system and how GFM converters can play a key role in this transition.

#### 4.7. *ESCRI-SA Project, Australia*

The ESCRI-SA project is developed by the TSO ElectraNet and involves a 30 MW/8 MWh grid-connected BESS (Figure 5). The system is located in South Australia near the Dalrymple substation and it is aimed at demonstrating how storage can strengthen the grid and improve reliability. The BESS system was manufactured by Consolidated Power Projects, in partnership with ABB and battery supplier Samsung. The project is partly funded by the Australian Renewable Energy Agency (ARENA). ElectraNet licenses the BESS to the private service provider AGL, which

## Dual Inverter Trial - Results

- VMM event captured 25/5/2021
- "H" Constant = 50
- Clear response of VMM responding to ROCOF

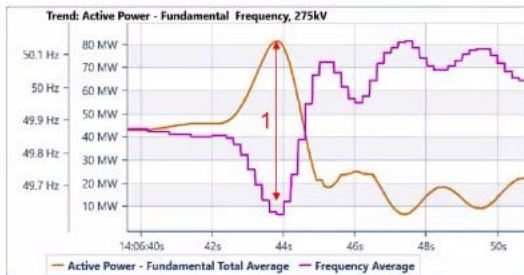

Site Response

[1] Max active power response at max frequency deviation

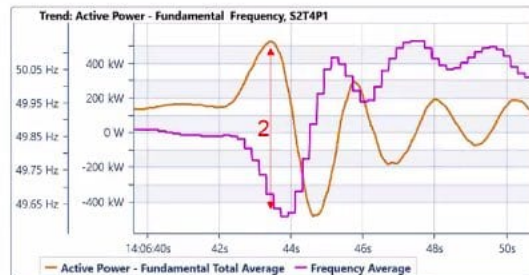

VMM Enabled Inverter Response

[2] Max active power response at max RoCoF

NEOEN

11

Figure 4: Hornsdale battery response to the grid tripping caused by Callide fault [60]

operates it to provide competitive market services. The ESCRI-SA BESS system consists of lithium-ion batteries integrated through dedicated inverters, controllers, and transformers. Battery capacity sizing was optimized according to criteria related to the ability to provide the following set of services:

- provision of fast frequency response with reduced network constraints;
- reduction of energy supply failure in case of islanding;
- participation in the energy market through ancillary frequency services.

The system was built with two identical strings of lithium-ion rechargeable batteries coupled to two sets of DC/AC inverters. The inverters provide power through six 33 kV transformers and they are connected via the BESS control room to the 132 kV Dalrymple substation through underground cables (Figure 5). The BESS has two levels of control. The first level, operated with priority over the second, is automated and it responds to system events according to a pre-programmed logic. The second level is dedicated to energy market and battery charging and it is controlled by AGL.

The ESCRI-SA BESS system is operated with grid-forming control strategy [61] [62]: the control scheme combines synthetic inertia, frequency controller, synchronous machine flow model, automatic voltage regulator and virtual impedance (Figure 6). The ESCRI-SA BESS system is also included as an integral part within the SIPS: the scheme is designed to prevent the separation of the South Australian system, to act promptly by containing the amount of Rate of Change of Frequency (RoCoF) in case of contingencies, and to operate based on measurements taken on the link to activate the injection of energy by the BESS system, with the ability to deliver full power in 250 ms.

Thus, the ESCRI-SA BESS project allows for both regulation and competitive market services. The regulation services are the reduction of energy non-delivery in the area (through transition to island operation) and the provision of synthetic inertia (with the reduction of operating constraints on the interconnection line). Market services are ancillary Contingency Frequency Control (C-FCAS for both up and down frequency variations) and participation in the wholesale energy market. In the future, the following services may also be monetized: black start of the 33



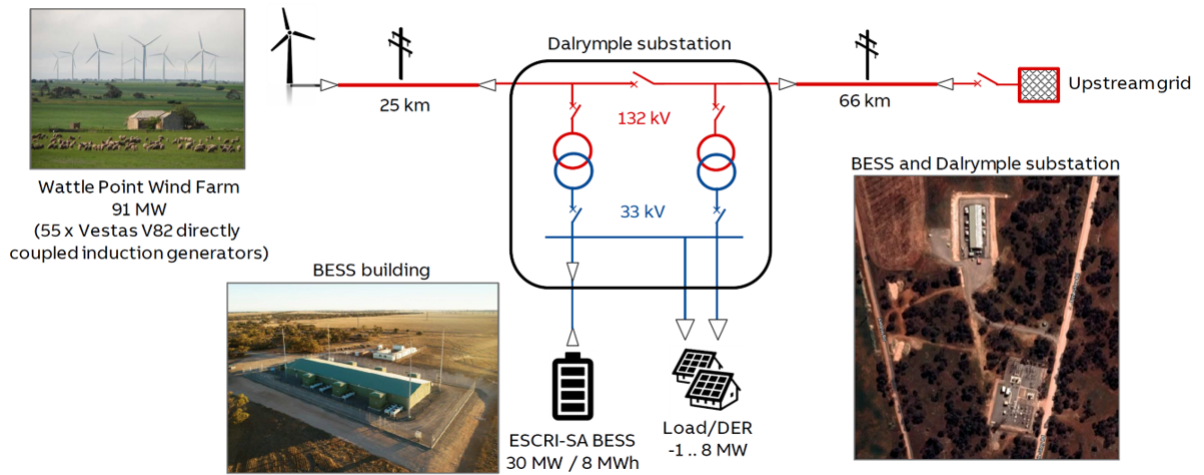

Figure 5: Schematic representation of the ESCRI-SA BESS system [61]

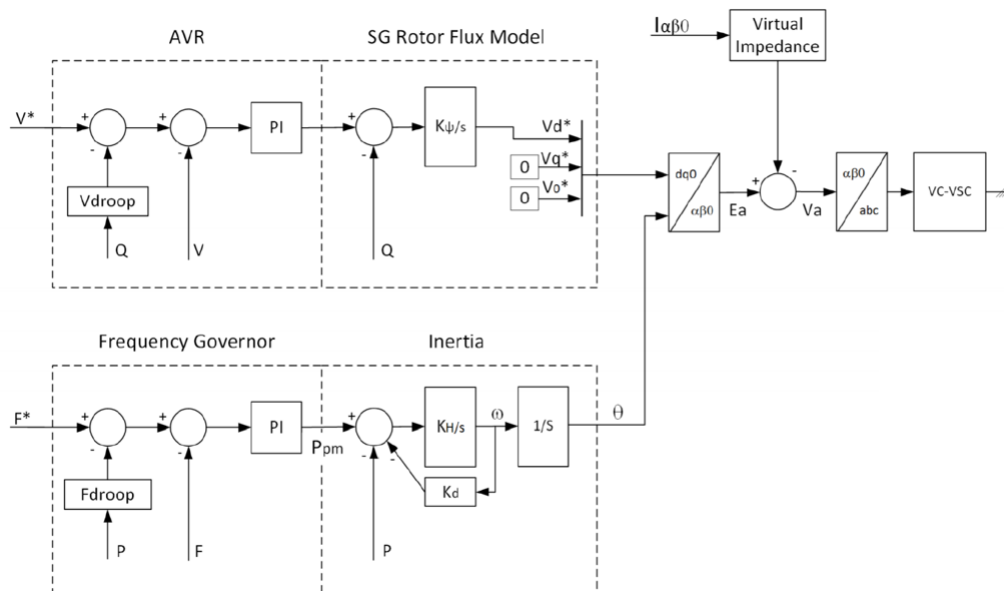

Figure 6: Model of Virtual Synchronous Machine by ABB [62]

kV local grid; system robustness and fault level support; rapid active power injection as part of the SIPS; voltage regulation with automatic triggering in the band beyond  $\pm 5\%$  of nominal value; and distributed energy resources curtailment in the case of island operation.

#### 4.8. La Plana Hybrid Project, Spain

The Hybrid Pilot Plant in La Plana (Spain), owned by Siemens Gamesa, was commissioned in 2015 and it is under testing since 2018 [63]. A hybrid plant consists in a multi-source energy generation system that is managed in order to obtain optimal operating conditions from both technical and economical point of view. This kind of system is often equipped with GFM converters for the purpose of providing also ancillary services from non-traditional generators. The reduction of variability in renewable energy provision is an important challenge that, if really solved, can lead to a massive penetration of renewable energy sources in the electrical system. In order to achieve this goal, hybrid plants are becoming increasingly important and interesting [64].

The plant in La Plana is made up of an 850 kW WTG, a 245 kW solar PV plant, three 222 kW diesel generators and a BESS. The system is shown in Figure 7. Two different storage technologies are installed: Lithium-ion (there 435 kW/145 kWh units) and Redox-Flow (one 120 kW/400 kWh unit). With these two types of batteries, it is possible to use the optimal one in relation to the service to be provided, distinguishing power-intensive (Li-Ion) from energy-intensive services (Redox-Flow). A controller coordinates the production of all generators with the aim to minimize the Life Cost of Energy (LCoE) of the plant in all operating conditions, regardless of whether the system is off-grid or grid-connected. The controller favors the energy from renewable sources, trying to keep diesel generators at minimum even in off-grid operation or in periods of contemporary lack of sun and wind. Gamesa Electric has provided all the power electronics of the plant, both for generators and batteries. The GFM inverters allow the plant to operate in Zero Diesel Operation mode or to reconnect to the grid after a black-out. Apart from energy saving purposes, this type of projects is attracting attention for its economic prospects in providing different services. Thanks to the storage units, this solution can be used for energy shifting application; thanks to the GFM capabilities, the plant can be allocated in strategic electrical nodes and provide ancillary services, such as frequency reserve and regulation, peak shaving, synthetic inertia, and black start.

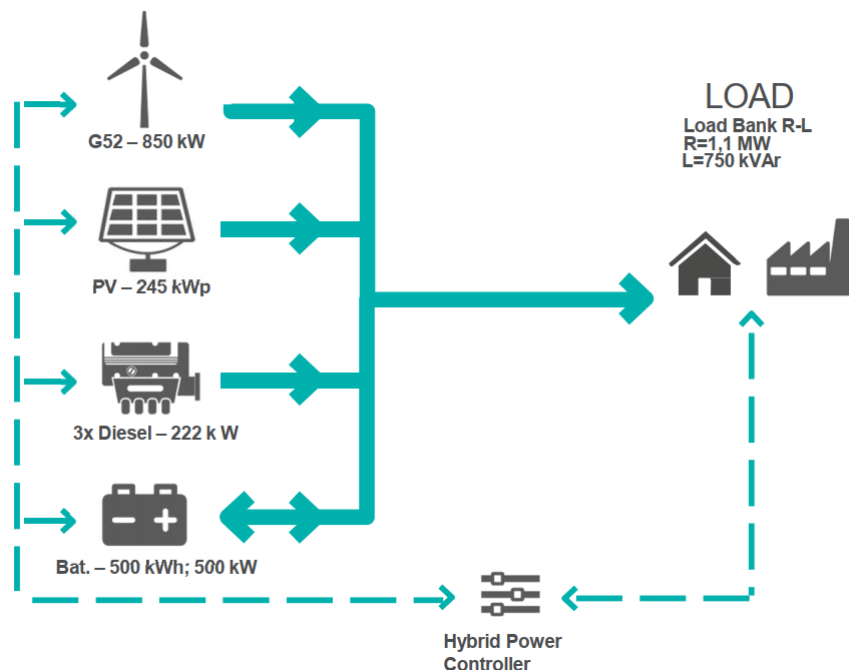

Figure 7: La Plana Hybrid Project [63]



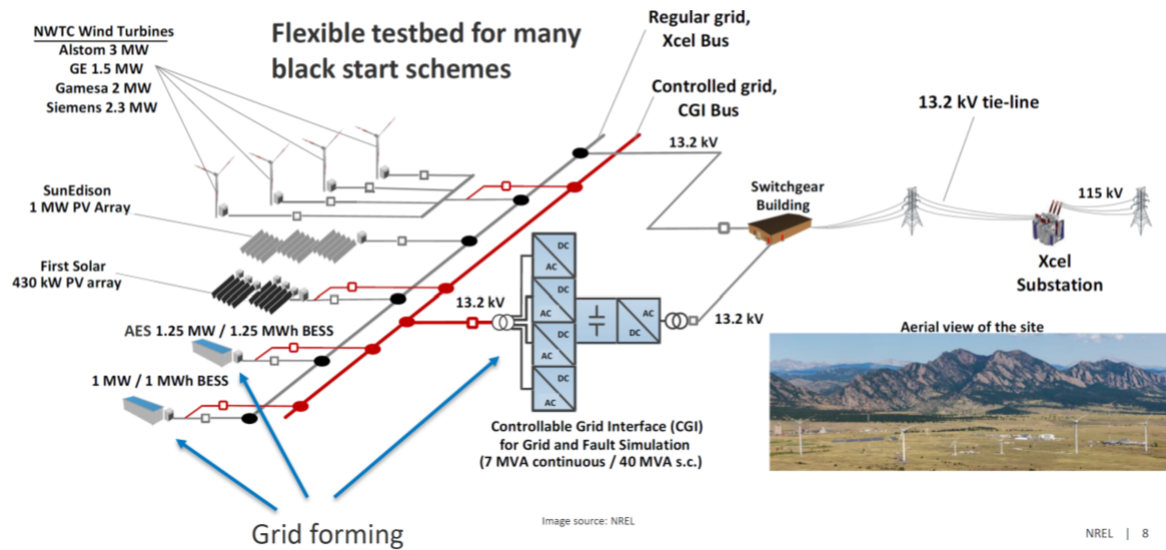

Figure 9: Schematic representation of the integrated NREL Campus system [66]

The transient response of the system for a load step test is shown in Figure 10. The figure shows frequency, voltage, active and reactive power of the BESS system following a disturbance consisting of the connection of a 500 kW/500 kVAR load [67]. The measurements are taken at the HV side of the BESS transformer, i.e., at the point of interconnection of the BESS system. The frequency is estimated by a PLL with a low-pass filter cutoff frequency of 10 Hz. The voltage and power signals are processed with a low-pass filter cutoff frequency of 10 Hz. The results show that the BESS system model is able to emulate the transient response of the system following a load step. The deviations between measurements and simulation in the case of frequency are due to the PLL dynamics: these deviations have however no influence on the transient response governed by the implemented frequency/active power droop. Other small deviations between measurements and simulations can be explained by the inaccurate knowledge of the inverter control structure, which is proprietary information of the manufacturer. It is important to note that the transient response of the inverter is closely related to the internal control circuits, the gradient limiters present, and the signal communication delays.

#### 4.11. General Electric Projects, USA

General Electric (GE) has shown significant interest in grid-forming technologies in recent years. The company's first installation dates back to 2017 and it consists of a BESS with lithium-ion technology located in California and operated by Imperial Irrigation District (IID), a fiscally responsible public agency whose mission is to provide reliable, efficient and affordably priced water and energy service to the communities it serves. GE provided all the inverters, controls and transformers, and it purchased the lithium-ion batteries from Samsung SDI America. Each set of batteries is connected to an inverter, which is connected to a transformer, as a separate storage system. There are a total of 30 inverters and 30 transformers making up the system that operates at a nominal voltage of 92 kV. The main role of the BESS is to be operated in a coordinated manner with the other conventional generators in order to provide support to the network [68].

Another important project managed by GE itself is the Lithium-Nickel-Manganese-Cobalt oxide (NMC) storage system installed at Entergy Louisiana's Perryville Power Station. The BESS enables black-start by creating a voltage reference to which the turbine and its associated auxiliary power systems can synchronize. Installed in December 2019, on February 2020 the BESS black-started a 150 MW gas turbine two times with the same recharge [69]. GE Research in April 2020 secured 4.2 million in funding from the US Department of Solar Energy Technologies Office (SETO) to develop grid-forming solar inverter control technologies [70]. This demonstrates how the interest in

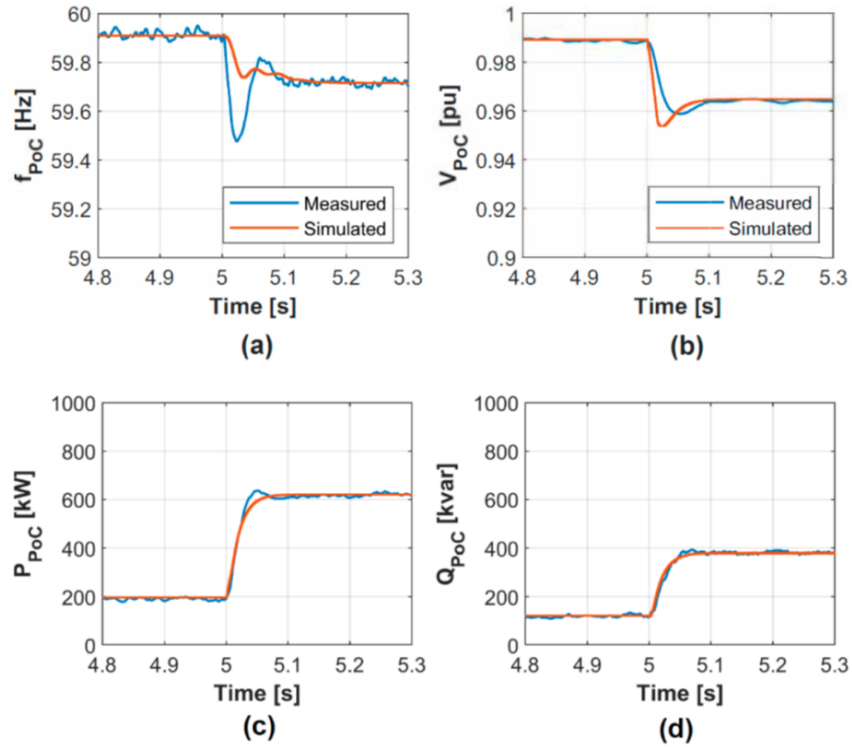

Figure 10: Transient response of the NREL system for a load step test [67]

grid-forming is not limited only to public bodies but also, and above all, to operators in the industrial sector who are producers of the technology.

#### 4.12. OSMOSE Project, Europe

The OSMOSE Project proposes various grid-forming demonstrators in order to evaluate the impact of the solutions on a wide and real electrical system [71] [72]. Financed on the Horizon 2020 research and innovation program, the project includes 33 partners among TSOs, industries, market operators, and research centers from 9 European countries. The WP3 of the project is titled: *Grid Forming for the synchronization of large power systems by multi-service hybrid storage*. In this WP, the behaviour of different storage systems controlled with GFM control schemes is investigated through simulations and experiments. The demonstrators are:

- an utility-scale BESS at Ecole Polytechnique Fédérale de Lausanne, (EPFL, Lausanne, Switzerland);
- a small-scale BESS at EPFL campus;
- a hybrid energy storage system (HESS) connected to the transmission grid (RingoLab, France).

The utility-scale BESS consists in a 720 kW/560 kWh Lithium-Titanate-Oxide (LTO) battery technology. This technology allows to reach 20000 complete charge/discharge cycles at the maximum rate, and it is an optimal solution for power-intensive applications. The BESS is equipped with a 720 kVA 4-quadrant full converter which can operate as a current source (grid-following) or as a voltage source (grid-forming). The system is connected to the EPFL campus medium voltage grid with a 630 kVA 0.3/20 kV step-up transformer. This installation represents an interesting case study due to the wider and random load variations and the presence of PV local generation (Figure 11).

The small-scale BESS is made up by a 25 kWh LTO battery connected to a 400 V microgrid by a 25 kW 4-quadrant converter. The demonstrator is equivalent to one string of the utility-scale BESS and it is for lab purposes.

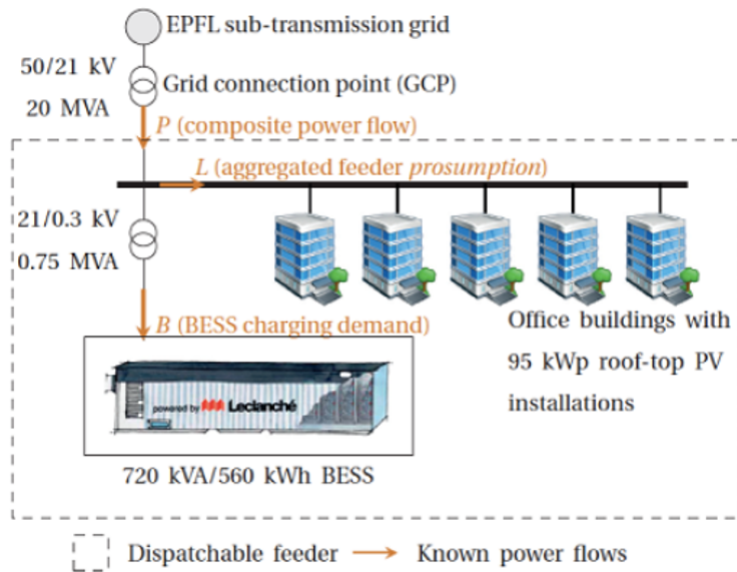

Figure 11: Schematic representation of the connection of the utility-scale BESS to the EPFL grid [71]

Also in this case, both grid-following and grid-forming control schemes can be applied.

The RingoLab is a HESS composed of six Lithium-ion battery racks (0.5 MVA/60 min) and six supercapacitor racks (1 MVA/10 s) controlled by a 1 MVA low voltage inverter. The size of the described components and all other devices (transformers, air conditioning, auxiliary equipment, etc.) fit in two 20 feet containers in order to limit the on-site encumbrance. This hybrid solution is designed to evaluate the synergy between the two different technologies, one for the fast peak response required by grid-forming control (supercapacitors) and the other for medium-long term energy provision during regulation (Lithium-ion batteries).

The WP3 tests are currently running, the last update dates back to November 2020. The utility scale BESS at EPFL has run from May 2020 to December 2020 and the first results about the assessment of local frequency variations when the BESS is set in VSC mode are positive. For RingoLab, instead, the Factory Acceptance Tests were completed in July 2020, but no results have been published yet.

#### 4.13. ABB Power Electronic Grid Simulator

ABB has proposed the commercial solution ACS6000 [73], a Power Electronic Grid Simulator (PEGS) designed for MV to test and validate grid codes conditions compliance of modern inverter-based generation systems. ACS6000 is essentially a GFM inverter that allows an accurate replication of MV power grids in both healthy and faulty operating mode: frequency and voltage changes of the grid can be simulated in order to match real operating condition, either symmetrical or asymmetrical. The power converter is made up by an active rectifier, DC link and three-phase multi-level NPC (Neutral Point Clamped) inverters. The output of the conversion portion is connected with a special transformer to increase the voltage. ACS6000 is also equipped with filters to guarantee acceptable total harmonic distortion (THD) values: even in the most severe simulations, THD is maintained below 1%. With its grid-forming architecture, the device is able to replicate different GFM methods, like f-P droop, VSM, and virtual oscillator. At the moment, over 2000 unit of ACS6000 converters operate in the world in the industry segment, thanks also to the possibility of conducting tests on cables, motors, and other electrical machines. Although this is not a proper demonstrator or a pilot project, this section has been included in the paper because it is the first commercial example of a device implementing the grid-forming capabilities.

#### 4.14. Fluence-Siemens for grid synchronization, Lithuania

Grid-forming converters play a key role not only in RES integration but also in providing fundamental electrical operations like grid synchronization. Lithuanian transmission network is connected to nearby countries (Latvia, Be-

larus, and Russia) with 330 kV power lines for a total of eleven interconnections. In 2019, it was signed a political agreement between Baltic states and European Union for the synchronization of the Baltic electrical system with the European grid [74]. Litgrid, the Lithuanian TSO, is responsible for this transition that will bring the countries to achieve independence from Russian frequency control operation and to participate in European energy market. Moreover, Lithuania plans to achieve a 45% of renewable energy supply in 2030, rising to around 100% in 2050. An important step to reach national carbon neutrality and grid synchronization consists in a project that involves Fluence, Siemens and Litgrid [75]. The project, announced in April 2021, is focused on the concept of “Virtual Transmission Lines” [76]: energy storage is placed along transmission lines in order to inject or absorb active and reactive power, emulating transmission line flows. The installation will take place near Vilnius, and it will be made by a 1 MW of storage capable to provide different network services including grid-forming functionalities, virtual inertia, black start capability and voltage control. This project is the first of a series of projects established in the agreement that will conduct the entire region to a new but safe and reliable electrical system before 2025.

## 5. Discussion

Table 1 synthesizes the main data acquired with the analysis of the pilot projects described in Section 4, providing a clear vision of the main features of real-life grid-forming experiences. The analysis of the demonstrators is useful to rise some questions about the current application of GFM control and future trends.

<i>Project</i>	<b>Owner</b>	<b>Kind of Owner</b>	<b>Location</b>	<b>Year</b>	<b>Rated Power [MW]</b>	<b>Energy Capacity [MWh]</b>	<b>Voltage Level</b>	<b>Applications*</b>
<i>Zurich BESS</i>	EKZ	Energy company	Switzerland	2012	1	0.58	LV-MV	AS, EM, IO
<i>Ausnet GESS</i>	AusNet	Energy Company	Australia	2012	1	1	MV	AS, IO
<i>Mackinac HVDC</i>	ATC	TSO	USA	2012	200	-	HV	HVDC
<i>SMA Projects</i>	Misc.	-	Europe - USA	2017-2019	0.8 - 15	0.4 - 15	LV-MV	RI, IO
<i>Dersalloch Wind Farm</i>	SPR	Energy Company	Europe	2019	69	-	MV	AS, BS, IO
<i>Hornsedale Power Reserve</i>	Neoen	Energy Company	Australia	2017-2020	150	194	HV	AS, EM
<i>ESCRI-SA Project</i>	Electranet	TSO	Australia	2018-2019	30	8	HV	AS, EM
<i>La Plana Hybrid Project</i>	Siemens-Gamesa	Energy Company	Europe	2018	-	-	MV	AS, BS, EM, IO
<i>DEMOCRAT Demonstrator</i>	Efacec	Energy Company	Europe	2018	0.25	0.22	LV-MV	BS, EM, IO
<i>NREL Campus</i>	NREL	Research Center	USA	2019	1.25	1.25	MV	AS, RI
<i>GE Projects</i>	Misc.	-	USA	2017-2019	-	-	MV	AS, BS
<i>OSMOSE Project</i>	Misc.	-	Europe	2018	0.1 - 0.72	0.025 - 560	LV-MV	RI
<i>ABB PEGS</i>	ABB	Component production Company	-	2020	20	-	MV	Other
<i>Fluence-Siemens Project</i>	Litgrid	TSO	Europe	2021	-	-	HV	Other

\* AS = Ancillary Services, BS = Black Start, EM = Energy Market, IO = Islanded Operations, RI = Renewables Integration

Table 1: Summary table of mentioned pilot projects

### What is the voltage level which the pilots are connected to?

In the majority of the cases analyzed, the pilot plants are connected to the MV grid. There are relatively few HV applications (only three projects provide services at this voltage level), while demonstrators connected to the LV grid are designed to provide services to the MV grid too. One explanation may be found in the reason that GFM converters are associated to BESS or PV or wind generators that are normally designed for LV and MV applications. Moreover the targets and services offered by the demonstrators are more compatible with distribution networks' needs than with transmission network's: black-start, islanded operation of microgrids, minimization of fuel consumption, etc. Another possible explanation for this trend may be the experimental nature of the projects: the preliminary testing phase, in fact, assumes a technological maturity that has not yet been fully reached and a performance of the services that is not yet clear. From this point of view, therefore, MV represents the right compromise between the need to test the effectiveness of the services and the costs associated with the installation and operation of the demonstrators.

### What is the average size of a grid-forming plant?

The rated power of GFM demonstrators depends heavily on the type of application. The highest power has been found for the Mackinac HVDC station. On the other hand, as far as BESSes are concerned, there are two distinct



groups: plants with rated power close to 1 MW and system with rated power of tens of megawatts. The first ones are most numerous (seven among those analyzed). Among the projects with rated power over 1 MW, the Australian plants in Hornsdale and ESCRI-SA are distinguished due to their very high sizes: 150 MW and 30 MW, respectively. The largest demonstrator in Europe is the Dersaloch one, not equipped with storage systems but exploiting the GFM capability of the converters of a wind farm. From this analysis, it can be inferred that there is greater interest in that part of the world in grid-forming technologies at industrial scale. The motivations can be tied both to the needs of the grid, that see in the grid-forming technologies an optimal solution, and to a legislative advancement such to allow the immediate insertion of these plants in the markets of belonging.

#### **Who are the grid-forming's stakeholders?**

Interest in grid-forming and its applications generally includes all actors involved in power generation and grid management sectors. From the analysis of the pilot projects, however, an important trend emerges with regard to the ownership of the plants: in most cases, in fact, the owners of the demonstrators are private companies (mainly power converter manufacturers: ABB, GE, Siemens, SMA, etc.) while a smaller part is owned by TSOs. The identified data is particularly relevant because it denotes a competitive economic potential since the early stages of experimentation, which can only be positive in terms of inclusion of this technology in the regulation of the grid and in the related economic mechanisms. Despite this, however, the importance of the role played by national legislative authorities and international standards organizations remains unchanged. It is fundamental, for the rapid and correct diffusion of these plants, that they be included in the national development plans as a concrete alternative to the current regulation and market schemes.

#### **What is the role of power converter manufacturer in grid-forming demonstrators?**

The experimentation and testing phase cannot disregard the production of components that are fit for the purpose. As far as grid-forming is concerned, however, the companies producing the components have shown great interest in investing in this technology. In all of the projects analyzed, manufacturers play an important role from the earliest stages of project conception and they also provide support in the testing phases. Emblematic is the example of ABB, active in almost all the projects analyzed and owner of the already mentioned ACS6000, a network simulator for the verification of compliance with network codes by the new equipment. The use of grid-forming technologies in the grid could lead, therefore, not only to a revolution in power generation and system management, but also to a paradigm shift in the component industry, which is why major manufacturers are often at the forefront of pilot projects and demonstrators.

#### **What are the main purposes of the grid-forming pilots?**

The versatility of grid-forming allows almost any type of application, whether for grid support or market operations. According to the analysis carried out, however, in the majority of cases the component related to the provision of ancillary services in medium and high voltage networks is emphasized. Of particular interest is also the possibility of black-start from non-conventional energy sources. This feature of grid-forming demonstrators is in fact one of the key points of the technology and it would allow a better management of the system also in view of a future decarbonization of it. Some of the demonstrators cited in Section 4 have, indeed, tested black-start in the absence of diesel generators. The integration of renewable sources and storage systems, moreover, can receive a significant boost from grid-forming converters, which can make possible the achievement of 100% of electricity supply from renewable sources, at least from a theoretical point of view. Last but not least, islanded operations are of particular interest in view of a possible change in the electricity system, with the creation of occasional and temporary islands to deal with possible failures or temporary network congestions.

#### **Did the demonstrators experiences show implementative issues for grid-forming control?**

From the project reports and scientific articles reviewed, it appears that all demonstrators have so far proved to be very good performers and capable of achieving their objectives. However, it should be noted that some of the projects listed are still in the testing phase.

## 6. Conclusions

The paper presented a review on pilot projects and demonstrators in the world with grid-forming capabilities, focusing on the technical characteristics of the various plants and on the services they can provide. The review was carried out by examining both scientific papers, regulatory documents, and case study reports, considering those project with major impact in terms of size of the plants and applications.

For each plant, rated values of power and voltage, locations, owners, and applications were discussed. Then, all this information were gathered in a dedicated table for a better overview. Starting from these data, some questions were raised-up by the authors in order to highlight similarities and differences among the demonstrators, and some interesting conclusions were drawn.

Some conclusions can be summarized from this study. Firstly, an important evidence that emerges from the analysis is the voltage level at which services are provided: many projects propose to provide ancillary services in medium voltage, which could be the prelude to what many TSOs have already anticipated, i.e. exploiting distribution networks for the provision of ancillary services, at the moment reserved for high voltage. Secondly, in the perspective of a complete decarbonisation of the electric system and of a greater integration of renewable sources, the capabilities related to black-start from non-conventional sources and to the possibility of carbon-neutral islanded operation constitute a valid incentive to research and experimentation of grid-forming plants.

From the considerations and the observations discussed in the paper, it appears that the grid-forming technology can potentially play a strategic role for future power systems, and in this context the experience gained through pilot projects and demonstrators has a fundamental importance.

## References

- [1] G. Donnini, E. Carlini, G. Giannuzzi, R. Zaottini, C. Pisani, E. Chiodo, D. Lauria, F. Mottola, On the estimation of power system inertia accounting for renewable generation penetration, in: 2020 AEIT International Annual Conference (AEIT), 2020, pp. 1–6. doi:10.23919/AEIT50178.2020.9241204.
- [2] D. Nouti, F. Ponci, A. Monti, Heterogeneous inertia estimation for power systems with high penetration of converter-interfaced generation, *Energies* 14 (16) (2021). doi:10.3390/en14165047. URL <https://www.mdpi.com/1996-1073/14/16/5047>
- [3] ENTSO-E, Need for synthetic inertia (si) for frequency regulation - entso-e guidance document for national implementation for network codes on grid connection, Tech. rep., ENTSO-E (2017).
- [4] M. Saeedian, R. Sangrody, M. Shahparasti, S. Taheri, E. Pouresmaeil, Grid-following dvi-based converter operating in weak grids for enhancing frequency stability, *IEEE Transactions on Power Delivery* (2021) 1–1 doi:10.1109/TPWRD.2021.3059898.
- [5] V. Di Dio, G. Sciumè, G. Zizzo, R. Musca, A. Vasile, Analysis of a fast reserve unit behaviour with additional modular synthetic inertia control, in: 2021 IEEE 15th International Conference on Compatibility, Power Electronics and Power Engineering (CPE-POWERENG), 2021, pp. 1–6. doi:10.1109/CPE-POWERENG50821.2021.9501206.
- [6] E. Rokrok, T. Qoria, A. Bruyere, B. Francoise, X. Guillard, Classification and dynamic assessment of droop-based grid-forming control schemes: Application in hvdc systems, *Electric Power Systems Research (EPSR)* 189 (2020) 106765.
- [7] J. Chen, M. Liu, F. Milano, T. O'Donnell, 100% converter-interfaced generation using virtual synchronous generator control: A case study based on the irish system *Electric Power Systems Research (EPSR)* 187 (2020) 106475.
- [8] P. Marinakis, N. Schofield, Dynamic interactions between inverters, grid forming invertersgrid forming control for power systems with up to 100% inverter based generation, in: The 9th Renewable Power Generation Conference (RPG Dublin Online 2021), Online, 1-2 March 2021, pp. 1–6.
- [9] H. M. A. Antures, S. M. Silva, D. I. Brandao, A. Augusto, P. Machado, R. V. Ferreira, A fault-tolerant grid-forming converter applied to ac microgrids, *International Journal of Electrical Power & Energy Systems* 121 (2020) 106072.
- [10] P. Glasziou, *How to write a Review*, John Wiley and Sons Publishing, 2013.
- [11] A. Engler, C. Hardt, P. Strauss, M. Vandenbergh, Parallel operation of generators for stand-alone single-phase hybrid systems-first implementation of a new control technology (01 2001).
- [12] K. Visscher, S. De Haan, Virtual synchronous machines (vsg's) for frequency stabilisation in future grids with a significant share of decentralized generation, in: CIREN Seminar 2008: SmartGrids for Distribution, 2008, pp. 1–4.
- [13] M. Paolone, C. Gaunt, X. Guillaud, M. Liserre, A. Meliopoulos, A. Monti, T. Van Cutsem, V. Vittal, C. Vournas, Fundamentals of power systems modelling in the presence of converter-interfaced generation, *Electric Power Systems Research* 189 (2020) 106811. doi:10.1016/j.epsr.2020.106811.
- [14] ENTSO-E, Grid-forming capabilities: Towards system level integration, Tech. rep., ENTSO-E (2021).
- [15] Y. Lin, J. H. Eto, B. Johnson, J. Flicker, R. Lasseter, H. V. Pico, G. Seo, B. Pierre, A. Ellis, Research roadmap on grid-forming inverters, Tech. rep., National renewable Energy Laboratory (NREL) (2020).
- [16] T. s.p.a, Piano di sviluppo 2021, Tech. rep., Terna (2021).
- [17] A. Johnson, Gc0100 - fast fault current injection, fault ride through and banding, Tech. rep., National Grid Eso (2020).
- [18] S. D'Arco, J. A. Suul, O. B. Fosso, A Virtual Synchronous Machine implementation for distributed control of power converters in SmartGrids, *Electric Power Systems Research* 122 (February 2015) 180–197. doi:10.1016/j.epsr.2015.01.001.

- [19] P. Unruh, M. Nuschke, P. Strauß, F. Welck, Overview on grid-forming inverter control methods, *Energies* 13 (10) (May 2020). doi:10.3390/en13102589.
- [20] R. Rosso, X. Wang, M. Liserre, X. Lu, S. Engelken, Grid-forming converters: Control approaches, grid-synchronization, and future trends – a review, *IEEE Open Journal of Industry Applications* 2 (April 2021) 93–109. doi:10.1109/OJIA.2021.3074028.
- [21] J. Rocabert, A. Luna, F. Blaabjerg, P. Rodriguez, Control of power converters in AC microgrids, *IEEE Transactions on Power Electronics* 27 (11) (May 2012) 4734–4749.
- [22] R. Hesse, D. Turschner, H.-P. Beck, Micro grid stabilization using the virtual synchronous machine (visma), in: *Proceedings of the International Conference on Renewable Energies and Power*, Valencia, Spain, 15–17 April 2009.
- [23] J. Matevosyan, B. Badrzadeh, T. Prevost, E. Quitmann, D. Ramasubramanian, H. Urdal, S. Huang, V. Vital, J. O’Sullivan, R. Quint, Grid-forming inverters: Are they the key for high renewable penetration?, *IEEE Power and Energy Magazine* 17 (6) (October 2019) 89–98. doi:10.1109/MPE.2019.2933072.
- [24] *ENTSO-E Technical Report*, High penetration of power electronic interfaced power sources and the potential contribution of grid forming converters (January 2020).
- [25] R. Rosso, J. Cassoli, G. Buticchi, S. Engelken, M. Liserre, Robust stability analysis of lcl filter based synchronverter under different grid conditions, *IEEE Transactions on Power Electronics* 34 (6) (2019) 5842–5853. doi:10.1109/TPEL.2018.2867040.
- [26] R. Rosso, S. Engelken, M. Liserre, Robust stability analysis of synchronverters operating in parallel, *IEEE Transactions on Power Electronics* 34 (11) (2019) 11309–11319. doi:10.1109/TPEL.2019.2896707.
- [27] Y. Liao, X. Wang, F. Liu, K. Xin, Y. Liu, Sub-synchronous control interaction in grid-forming vsocs with droop control, in: *2019 4th IEEE Workshop on the Electronic Grid (eGRID)*, 2019, pp. 1–6. doi:10.1109/eGRID48402.2019.9092640.
- [28] X. Wang, M. G. Taul, H. Wu, Y. Liao, F. Blaabjerg, L. Harnefors, Grid-synchronization stability of converter-based resources—an overview, *IEEE Open Journal of Industry Applications* 1 (2020) 115–134. doi:10.1109/OJIA.2020.3020392.
- [29] B. Weise, A. Korai, A. Constantin, Comparison of selected grid-forming converter control strategies for use in power electronic dominated power systems, in: *Proceedings of the 18<sup>th</sup> Wind Integration Workshop*, Dublin, Ireland, 16-18 October 2019.
- [30] A. Khaledia, M. A. Golkar, Analysis of droop control method in an autonomous microgrid, *Journal of Applied Research and Technology* 15 (March 2017) 371–377.
- [31] K. D. Brabandere, B. Bolsens, J. V. den Keybus, A. Woyte, J. Driesen, R. Balmans, A voltage and frequency droop control method for parallel inverters, *IEEE Transactions on Power Electronics* 22 (4) (July 2007) 1107–1115.
- [32] L. Zhang, L. Harnefors, H.-P. Nee, Power-synchronization control of grid-connected voltage-source converters, *IEEE Transactions on Power Systems* 25 (2) (May 2010) 809–820. doi:10.1109/TPWRS.2009.2032231.
- [33] L. Harnefors, M. Hinkkanen, U. Riaz, F. M. M. Rahman, L. Zhang, Robust analytic design of power-synchronization control, *IEEE Transactions on Industrial Electronics* 66 (8) (August 2019) 5810–5819.
- [34] Q.-C. Zhong, G. Weiss, Synchronverters: Inverters that mimic synchronous generators, *IEEE Transactions on Industrial Electronic* 58 (4) (April 2011) 1259–1267.
- [35] Q.-C. Zhong, P.-L. Nguyen, Z. Ma, W. Sheng, Self-synchronized synchronverters: inverters without a dedicated synchronization unit, *IEEE Transactions on Power Electronics* 29 (2) (February 2014) 617–630.
- [36] S. D’Arco, J. A. Suul, Virtual synchronous machines classification of implementation and analysis of equivalence to droop controllers for microgrids, in: *Proceedings of the IEEE PowerTech 2013*, Grenoble, France, 16-20 June 2013.
- [37] A. J. Roscoe, M. Yu, A. Dyško, C. Booth, R. Ierna, J. Zhu, H. Urdal, A VSM (Virtual Synchronous Machine) convertor control model suitable for RMS studies for resolving system operator owner challenges, in: *Proceedings of the 15<sup>th</sup> Wind Integration Workshop*, Vienna, Austria, 15-17 November 2016.
- [38] H. Bevrani, T. Ise, Y. Miura, Virtual synchronous generators: A survey and new perspectives, *Electric Power Systems Research* 54 (January 2014) 244–254.
- [39] M. Yu, A. J. Roscoe, C. D. Booth, A. Dysko, R. Ierna, J. Zhu, H. Urdal, Use of an inertia-less virtual synchronous machine within future power networks with high penetrations of converters, in: *Proceedings of the 2016 Power Systems Computation Conference (PSCC)*, Genoa, Italy, 20-24 June 2016.
- [40] C. Arghir, T. Jouini, F. Dörfler, Grid-forming control for power converters based on matching of synchronous machines, *Automatica* 95 (September 2018) 273–282.
- [41] T. Noguchi, H. Tomiki, S. Kondo, I. Takahashi, Direct power control of PWM converter without power-source voltage sensors, *IEEE Transactions on Industry Applications* 34 (3) (June 1998) 473–479.
- [42] M. Ndreko, S. Rüberg, W. Winter, Grid forming control scheme for power systems with up to 100% power electronic interfaced generation: a case study on great britain test system, *IET Renewable Power Generation* 14 (8) (June 2020) 1268–1281. doi:10.1049/iet-rpg.2019.0700.
- [43] P. Rodriguez, C. Citro, I. Candela, J. Rocabert, P. Rodriguez, Flexible grid connection and islanding of SPC-based PV power converters, *IEEE Transactions on Industry Applications* 54 (3) (May 2018) 2690–2702.
- [44] B. Johnson, M. Sinha, N. Ainsworth, F. Dörfler, S. V. Dhople, Synthesizing virtual oscillators to control islanded inverters, *IEEE Transactions on Power Electronics* 31 (8) (August 2016) 6002–6015.
- [45] Z. Shi, J. Li, H. Nurdin, J. Fletscher, Comparison of virtual oscillator and droop controlled islanded three-phase microgrids, *IEEE Transactions on Energy Conversion* 34 (4) (December 2019) 1769–1780.
- [46] M. Koller, M. Gonzalez Vaya, A. Chacko, T. Borsche, A. Ulbig, Primary control reserves provision with battery energy storage systems in the largest european ancillary services cooperation, 2016.
- [47] M. Koller, T. Borsche, A. Ulbig, G. Andersson, [Review of grid applications with the zurich 1mw battery energy storage system](#), *Electric Power Systems Research* 120 (2015) 128–135, smart Grids: World’s Actual Implementations. doi:https://doi.org/10.1016/j.epsr.2014.06.023.  
URL <https://www.sciencedirect.com/science/article/pii/S0378779614002326>
- [48] ABB Australia, Battery/diesel grid-connected microgrids: a large-scale, industry-based case study of future microgrid capabilities, White

- paper, ABB, 2015.
- [49] AusNet Electricity Services Pty Ltd, Demand Management Innovation Allowance Annual Report 2016, Annual report, AusNet Services, 2017.
  - [50] AusNet Electricity Services Pty Ltd, Demand Management Case Study, Grid Energy Storage System, Project report, AusNet Services, 2017.
  - [51] M.B. Marz, Mackinac vsc hvdc flow control project design, in: Minnesota Power Systems Conference, 2012.
  - [52] M. B. Marz, Mackinac hvdc construction and testing, 2014.
  - [53] SMA, Experiences with large grid-forming inverters on various islands and microgrid projects, in: Hybrid Power Systems Workshop, Crete, Greece, 2019.
  - [54] A. Baars, The bordesholm stand-alone grid ensures power supply even in the event of a grid failure, <https://www.sma-sunny.com/en/the-bordesholm-stand-alone/> (June 2020).
  - [55] A. Roscoe et. al., Practical experience of operating a grid forming wind park and its response to system events, in: 18th Wind Integration Workshop, 2019.
  - [56] A. Roscoe et. al., Practical experience of providing enhanced grid forming services from an onshore wind park, in: 19th Wind Integration Workshop, 2020.
  - [57] Aurecon, Hornsdale power reserve - year 1 technical and market impact case study, 2018.
  - [58] Aurecon, Hornsdale power reserve - year 2 technical and market impact case study, 2020.
  - [59] Mark Ludlow, [Inside the callide c power station disaster](https://www.afr.com/companies/energy/inside-the-callide-c-power-station-disaster-20210602-p57xai) (2021).  
URL <https://www.afr.com/companies/energy/inside-the-callide-c-power-station-disaster-20210602-p57xai>
  - [60] Giles Parkinson, ["virtual machine": Hornsdale battery steps in to protect grid after callide explosion](https://reneweconomy.com.au/virtual-machine-hornsdale-battery-steps-in-to-protect-grid-after-callide-explosion/) (2021).  
URL <https://reneweconomy.com.au/virtual-machine-hornsdale-battery-steps-in-to-protect-grid-after-callide-explosion/>
  - [61] S. Cherevatskiy, S. Zabihi, R. Korte, H. Klingenberg, A 30 mw grid forming bess boosting reliability in south australia and providing market services on the national electricity market, in: 18th Wind Integration Workshop, Dublin, Ireland, 2019.
  - [62] A. Tuckey, S. Round, Practical application of a complete virtual synchronous generator control method for microgrid and grid-edge applications, in: 2018 IEEE 19th Workshop on Control and Modeling for Power Electronics (COMPEL), Padova, Italy, 2018.
  - [63] Siemens, G. Electric, Siemens gamesa hybrid solutions, leading the way to a renewable powered future, 4th International Hybrid Power Systems Workshop, greece (2019).
  - [64] G. Electric, Gamesa electric at la plana hybrid pilot plant, <https://www.gamesaelectric.com/gamesa-electric-at-siemens-gamesas-la-plana-hybrid-pilot-plant/> (2019).
  - [65] M. Ribeiro, L. Marques, I. Miranda, A. Bernardo, Democrat: Demonstrator of a micro-grid integrating storage, in: CIRED 2018 Ljubljana Workshop, Ljubljana, Slovenia, 2018.
  - [66] V. Gevorgian, S. Shah, P. Koralewicz, Modeling challenges: Dynamic interactions between inverters, grid forming inverters, in: Challenges for Distribution Planning, Operational and Real-time Planning Analytics Workshop, Washington, USA, 2019.
  - [67] L. Petersen, F. Iov, G. C. Tarnowski, V. Gevorgian, P. Koralewicz, D. Stroe, Validating performance models for hybrid power plant control assessment, *Energies* 12 (4330) (2019).
  - [68] Chris Beltran, [Battery Deployments Solve Grid Challenges](https://www.tdworld.com/grid-innovations/generation-and-renewables/article/20969604/battery-deployments-solve-grid-challenges), T&D World, 2017.  
URL <https://www.tdworld.com/grid-innovations/generation-and-renewables/article/20969604/battery-deployments-solve-grid-challenges>
  - [69] Sonal Patel, [GE Achieves Battery-Enabled Blackstart of Heavy Duty Gas Turbine](https://www.powermag.com/ge-achieves-battery-enabled-blackstart-of-heavy-duty-gas-turbine/), Power-News & Technology for the Global Energy Industry, 2020.  
URL <https://www.powermag.com/ge-achieves-battery-enabled-blackstart-of-heavy-duty-gas-turbine/>
  - [70] Emiliano Bellini, [General Electric works on grid-forming inverter controls](https://www.pv-magazine.com/2020/04/06/general-electric-works-on-grid-forming-inverter-controls/), PV Magazine, 2020.  
URL <https://www.pv-magazine.com/2020/04/06/general-electric-works-on-grid-forming-inverter-controls/>
  - [71] E. Namor, F.Sossan, R. Cherkaoui, M. Paolone, Deliverable 3.1, multi-service control algorithm for converters, Tech. rep., OSMOSE Project (2018).
  - [72] T. Prevost, Y. vernay, C. Cardozo, G. Denis, Y. Zuo, A. Zecchino, R. Cherkaoui, M. paolone, M. Z. Lazkano, J. Valera, Deliverable 3.2, overall specifications of the demonstrations, Tech. rep., OSMOSE Project (2019).
  - [73] ABB, [Abb's acs6000 power electronics grid simulator, pegs, tests medium voltage equipment](https://new.abb.com/news/detail/62430/abbs-acs6000-power-electronics-grid-simulator-pegs-tests-medium-voltage-equipment), <https://new.abb.com/news/detail/62430/abbs-acs6000-power-electronics-grid-simulator-pegs-tests-medium-voltage-equipment> (2020).
  - [74] ENTSO-E, First milestone of future synchronous connection of the baltic power system with continental europe, <https://www.entsoe.eu/news/2019/05/29/first-milestone-of-future-synchronous-connection-of-the-baltic-power-system-with-continental-europe/> (2019).
  - [75] Fluence, Fluence, siemens and litgrid partner on baltics' first storage as transmission pilot project, <https://blog.fluenceenergy.com/fluence-siemens-litgrid-partner-baltics-first-storage-as-virtual-transmission-pilot-project> (2021).
  - [76] K. Kumaraswamy, J. Cabbabe, H. Wolfschmidt, Redrawing the network map: Energy storage as virtual transmission, <https://info.fluenceenergy.com/energy-storage-as-virtual-transmission-white-paper-download>, white paper (2020).